

# water chillers and boilers

---

NATURE'S WATER:  
ALWAYS FRESH AND  
COLD OR BOILING HOT



 **WATERWARE**  
ENWARE AUSTRALIA PTY LIMITED

[WWW.ENWARE.COM.AU](http://WWW.ENWARE.COM.AU)



**THE LAST THING YOUR CLIENTS NEED TO WORRY ABOUT IS HAVING ENOUGH CHILLED OR BOILING WATER ALWAYS ON TAP.**

**ENWARE HAS THE SOLUTION: NATURE'S WATER ON DEMAND, ALWAYS FRESH AND CHILLED OR PIPING HOT.**

Enware's Waterware range incorporates proven water technology with water chillers and boiling units that make it all so easy - in a choice of attractive free-standing or under-counter models that deliver quality water in a range of capacities.

## ATTRACTIVE, FREE-STANDING WATER CHILLERS

Clever and practical free-standing chillers deliver cool, fresh, mains pressure drinking water at the press of a button.

- Up to 18 litres chilled water per hour
- Hygienic, polished stainless steel tops designed for rapid draining
- Adjustable levelling feet
- Stainless steel storage tank
- FDA approved internal pipework
- Environmentally friendly R134A refrigerant

### OPTIONS

- Carafe/glass filler
- Carbon filter
- Brushed stainless or Powder coated finish



### SITE CHILLER

Heavy-duty water chillers designed to take the hard knocks of tough industrial sites.

Order Code: **DFS100S**



Order Code: **DFS121**



Order Code: **DFS101**



Order Code: **DFS100**



Order Code: **DFS120**

## TECHNICAL INFORMATION

Model No.	Description	Finish Side Panel	Flow Rate (l/hp)	Compressor Size (hp)	Condenser	Refrigerant	Storage Tank (litres)	Dimensions (mm)	Mass (kg)
<b>DFS100</b>	Free Standing Bubbler	Powder Coat	18	1/6	Dual	R134A	4	940Hx330Wx320D	28
<b>DFS101</b>	Free Standing Bubbler	Stainless	18	1/6	Dual	R134A	4	940Hx330Wx320D	28
<b>DFS120</b>	Free Standing Bubbler + Carafe	Powder Coat	18	1/6	Dual	R134A	4	940Hx330Wx320D	28
<b>DFS121</b>	Free Standing Bubbler + Carafe	Stainless	18	1/6	Dual	R134A	4	940Hx330Wx320D	28
<b>DFS100S</b>	Site Model - Bubbler	Zinc Seal	18	1/6	Dual	R134A	4	940Hx330Wx320D	28

## WATERWARE WATER CHILLER ACCESSORIES

### CARAFE/GLASS FILLER KIT (pictured)

- Suits all under counter and multi-point models
- Includes 1.5m tubing with 9/16" brass compression fittings

Order Code: **DFS010**

### CARBON FILTER

- Optional - suits all models

Order Code: **DFS002F**



### PUSH BUTTON BUBBLER OUTLET (pictured)

- For Multi-point Chillers or as a spare part for free standing chillers

Order Code: **BUB290**

### BUBBLER OUTLET REPLACEMENT CARTRIDGE

- Fits BUB290 bubbler outlet

Order Code: **BUB294**



## CONVENIENT UNDER COUNTER WATER CHILLER

Creates a clever use of space with the Waterware Under Counter Water Chiller. This unit hides neatly away and delivers pure refreshment all day long.

- Provides up to 16 litres of mains pressure, chilled water per hour Stainless steel storage tank and pipework
- Louvred front panel for ventilation
- Easy access for maintenance
- Environmentally friendly R134A refrigerant
- Optional carbon filter for cleaner water

**Order Code:**  
**DUC200**

*\*See Waterware Water Chiller Accessories for bubbler and carafe/glass filler outlets, which are sold separately. For more outlet choices please contact Enware.*



### TECHNICAL INFORMATION

Model No.	Description	Finish Side Panel	Flow Rate (l/hp)	Compressor Size (hp)	Condenser	Refrigerant	Storage Tank (litres)	Dimensions (mm)	Mass (kg)
DUC200	Under Counter	Powder Coat	16	1/6	Dual	R134A	3	310Hx420Wx300D	19

## PRACTICAL REMOTE MULTI-POINT WATER CHILLER

For higher demand applications choose the Waterware Remote Multi-Point Water Chiller. This unit is capable of servicing multiple outlets.

- Provides up to 96 litres of mains pressure, chilled water per hour Stainless steel storage tank and pipework
- Louvred panels for ventilation
- Side panel access for easy maintenance
- Environmentally friendly R134A refrigerant
- Optional carbon filter for cleaner water

**Order Code:**  
**DRC100**

*\*See Waterware Water Chiller Accessories for bubbler and carafe/glass filler outlets, which are sold separately. For more outlet choices please contact Enware.*



### TECHNICAL INFORMATION

Model No.	Description	Finish Side Panel	Flow Rate (l/hp)	Compressor Size (hp)	Condenser	Refrigerant	Storage Tank (litres)	Dimensions (mm)	Mass (kg)
DRC100	Remote Multi-Point	Powder Coat	96	1/2	Aluminium Finned	R22	65	885Hx510Dx710W	62

## BARRIER FREE DRINKING FOUNTAINS

Enware can combine a Barrier Free Drinking Fountain with an Under Counter Water Chiller to provide a refreshing, accessible compliant drinking fountain solution. Contact Enware for more information.



#### DELUXE ACCESSIBLE

- Wall Mounted Drinking Fountain

**Order Code: CDF300D**



#### DELUXE ACCESSIBLE

- Hi-Lo Wall Mounted Drinking Fountain

**Order Code: CDF320D**



#### DRINKING FOUNTAIN

- Accessible Wall Mounted

**Order Code: CDF330D**



#### DRINKING FOUNTAIN

- Accessible Hi-Lo Wall Mounted

**Order Code: CDF340D**

# ENERGY SAVING INSTANT BOILING WATER WITH PROGRAMMABLE TIMERS

## THE WATERWARE RANGE OF ENERGY EFFICIENT BOILING WATER UNITS HAVE BEEN DESIGNED WITH TODAY'S ENERGY CONSCIOUS USER IN MIND.

A timer allows you to program when boiling water is not required to turn the unit off for maximum savings, whilst a clever sleep mode senses when no one is around and powers-down to conserve energy. These features save around 40% of the energy normally used and means Waterware instant boiling water units meet BCA requirements for energy efficiency.

- Electronic controls which control all functions automatically
- Programmable 7 day timer and sleep mode
- Auto boiling point calibration
- Attractive white powder coat finish
- High efficiency CFC free insulation
- 1 year warranty

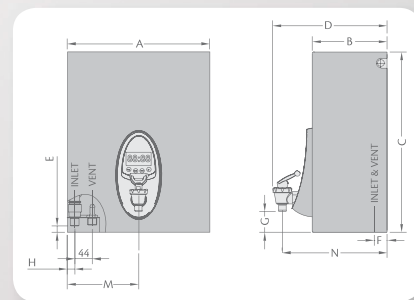

### DIMENSIONS (Dimension refer to diagram right - mm)

Model No	A	B	C	D	E	F	G	H	N	M
WBLU030	283	143	400	234	15	50	53	15	212	142
WBLU050	334	176	430	267	15	50	53	18	245	167
WBLU075	490	325	615	416	8	32	103	32	394	245

## TECHNICAL INFORMATION

\*one cup = 200mls

	WBLU030	WBL050	WBL075
Storage Capacity	3 litre	5 litre	7.5 litre
Initial Draw-off	20 cups	35 cups	50 cups
Recovery/hour	103 cups	123 cups	123 cups
No. of cups 1st hour	123 cups	158 cups	173 cups
Electrical Load (A)	8	10	10
Heating Element Input (kW)	1.8	2.4	2.4
Wiring	3 pin plug (2 metre cord and plug supplied)	3 pin plug (2 metre cord and plug supplied)	3 pin plug (2 metre cord and plug supplied)
Inlet Connection ("/mm)	R 1/2-15 (1/2 BSP male)	R 1/2-15 (1/2 BSP male)	R 1/2-15 (1/2 BSP male)
Overflow Connection ("/mm)	R 1/2-15 (1/2 BSP male)	R 1/2-15 (1/2 BSP male)	R 1/2-15 (1/2 BSP male)
Min Water Supply Pressure (kPa)	50	50	50
Max Water Supply Pressure (kPa)	1000	1000	1000

## ENWARE IN BRIEF

Enware is a world-leading Australian designer and manufacturer of quality specialist commercial tapware solutions and safety systems.

Since inception in 1937, Enware Australia has grown significantly. Today, Enware has offices located around the country and is represented in major regions throughout the world including Asia, the Pacific, the Middle East and Europe. As a global leader of specialist tapware and safety systems, Enware offers a more extensive range than any other company on the market.

SPECIALIST  
PLUMBING SOLUTIONS

ADAPTABLE WORK  
& LIVING SOLUTIONS

ENVIRONMENTAL, HEALTH  
& SAFETY SOLUTIONS

STAINLESS STEEL  
WASHROOM SYSTEMS



ADDRESS: 9 Endeavour Road, Caringbah NSW 2229 Australia  
 POSTAL ADDRESS: P.O. Box 2545, Taren Point NSW 2229 Australia  
 PHONE: 61 2 8536 4000 FAX: 61 2 8556 4055  
 1300 369 273 (AUS) WWW.ENWARE.COM.AU INFO@ENWARE.COM.AU

