

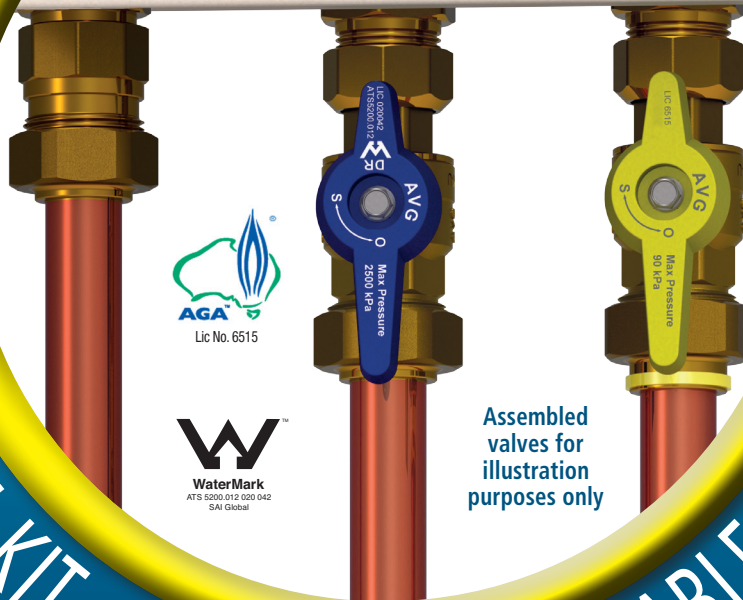

Australian Valve Group

Quickie-^U

UNIVERSAL KIT with INTER-CHANGABLE ADAPTORS



Assembled valves for illustration purposes only

ONE kit fits ALL

QUICK CONTINUOUS FLOW KIT

Quickie-U

QUICK CONTINUOUS FLOW UNIVERSAL KIT

The Quick Continuous Flow Kit (Quickie-U) is a universal kit which includes a loose nut to male ball valve with optional inlet and outlet end connection adaptor options.

The Quickie-U Kit has been developed to allow the installing plumber to decide what kit configuration is required at the point of installation.

One of the major advantages to this approach is that the plumbing merchant only needs to carry one kit on the shelf and the installing plumber one kit in their vehicle.

This not only saves cash flow but valuable shelf space and peace of mind.

Currently the only options available to the plumbing merchant and the plumber are a range of purpose built ball valves and outlet fittings with fixed inlet and outlet connections. This means that they both have to carry extra products on the shelf and in their vehicles to cater for differing continuous flow water heater inlet and outlet configurations and installation requirements.

DESCRIPTION

The Quick Continuous Flow Kit includes everything required to install a variety of different continuous flow hot water heaters, two loose nut ball valves, one water and one gas and a hot water outlet fitting.

Also included in the kit is a range of optional inlet and outlet connection adaptors for the water and gas ball valves and the outlet fitting, this allows the installing plumber to make their selection and fit the appropriate adaptors as required on site.



FEATURES:

- Everything you need to install a continuous flow hot water heater in ONE box
- One kit fits ALL
- Water isolation ball valve with optional 15mm and 20mm compression inlet adaptors with optional 15mm reducing outlet adaptor complete with seal
- Gas isolation ball valve with optional 15mm and 20mm flared inlet adaptors with optional 15mm reducing outlet adaptor complete with seal
- Hot water outlet fitting with optional 15mm and 20mm outlet adaptors with optional 15mm reducing inlet adaptor with seal
- Special tool to fit reducing adaptors

ONE kit fits ALL

QIK-UNIVERSAL GAS
 QUICK UNIVERSAL GAS VALVE



GAS

The QIK20-U Gas valve is supplied as ONE valve with the option of either 15mm or 20mm flared inlet connections, no more arriving on site with the wrong size valve. The on site assembly diagram says it all.

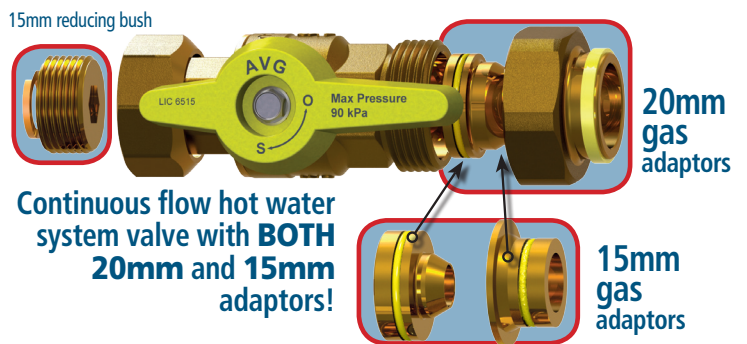

QIK-UNIVERSAL WATER
 QUICK UNIVERSAL WATER VALVE



WATER

The QIK20-U Water valve is supplied as ONE valve with the option of either 15mm or 20mm compression inlet connections, no more arriving on site with the wrong size valve. The on site assembly diagram says it all.

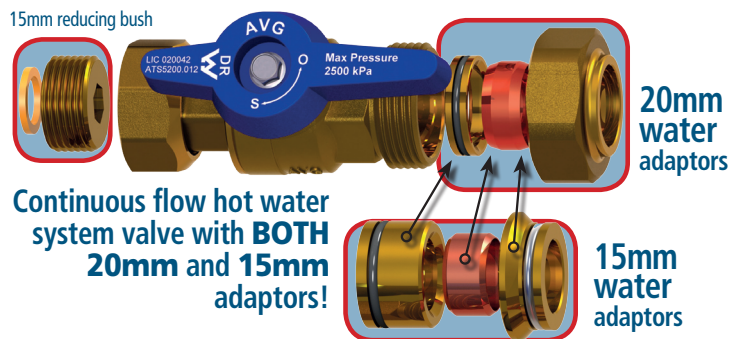

QIK-UNIVERSAL HWO
 QUICK UNIVERSAL HWO FITTING



HWO

The QIK20-U HWO fitting is supplied with the option of either 15mm or 20mm compression inlet connections, no more arriving on site with the wrong fitting. The on site assembly diagram says it all.

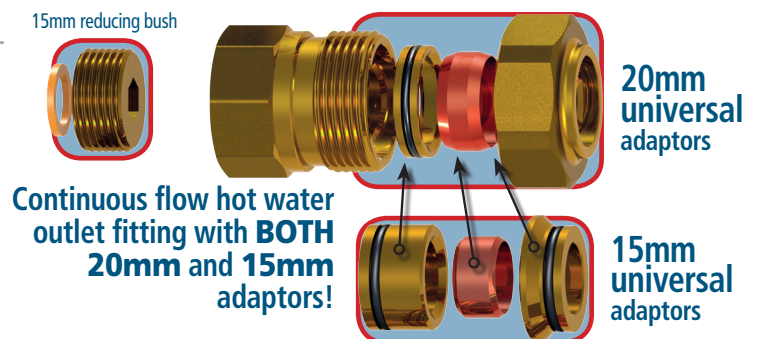

installation

INSTRUCTIONS

20MM GAS ADAPTORS

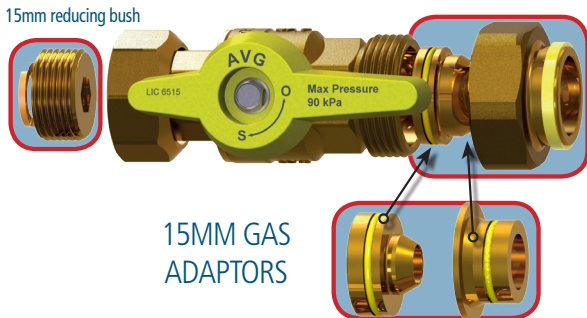

FLARED ADAPTOR OPTIONS

First fit the nut and slide it onto the 3/4" copper tube and flare the tube. Fit the 3/4" flared adaptor into the male connection of the ball valve then connect the tube and tighten the nut to achieve a 3/4" flared connection.

To achieve a 1/2" flared connection just select the 1/2" flared tube support adaptor and fit it into the nut. Then slide the nut onto the 1/2" copper tube and flare the tube. Fit the 1/2" flared adaptor into the male connection of the ball valve then connect the tube and tighten the nut.

20MM WATER ADAPTORS

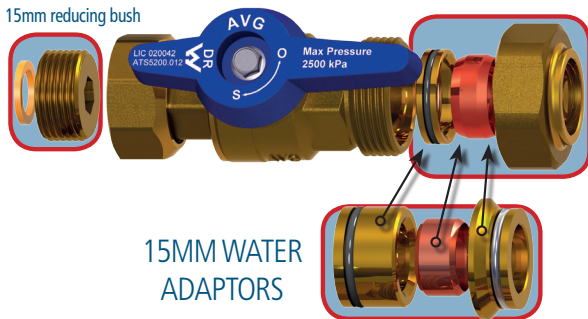

COMPRESSION ADAPTOR OPTIONS

By fitting the 3/4" tube stop adaptor into the male connection of the ball valve or the hot water outlet fitting and then fit the nut and the 3/4" copper olive onto the copper tube a 3/4" compression plumbing connection can be achieved. Just connect the tube and tighten the nut.

To achieve a 1/2" compression plumbing connection just select the 1/2" tube stop adaptor and fit it into the male connection of the ball valve or the hot water outlet fitting. Then fit the the 1/2" tube support adaptor into the nut and slide the nut and the 1/2" copper olive onto the copper tube. Just connect the tube and tighten the nut.

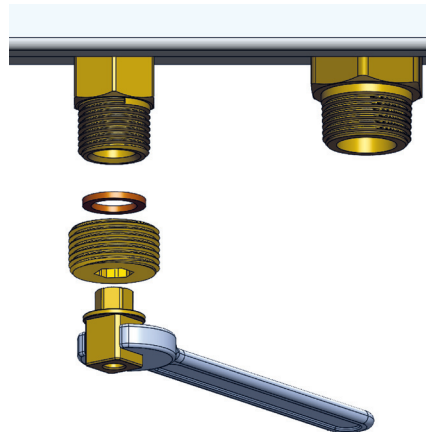

FITTING THE 15MM (1/2") REDUCING BUSH

To fit the valve to a 15mm (1/2") connection to a water heater, first fit the seal into the 15mm (1/2") loose nut adaptor, using the tool supplied screw the adaptor onto the male connection of the water heater and tighten. Then fit the valve.

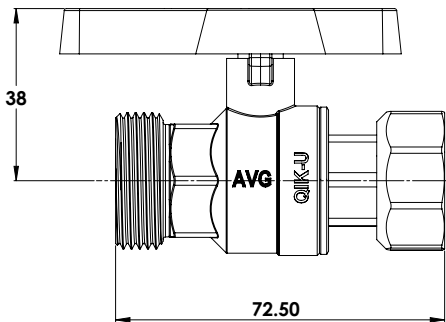

SPECIFICATIONS:

GAS AND WATER QUARTER TURN ISOLATION BALL VALVES

Pressure Rating:	90 kPa
Temp. Rating:	0-60°C
Body:	DR Brass body & internal components
"O" Rings & Seals:	HNBR
Ball Seals:	PTFE
Handles:	Powder coated aluminium
Approvals:	



Quick Continuous Flow Universal Kit

AVG

Australian Valve Group

Australian Valve Group (Head Office)

Unit 2, 9-11 Noble St, Kewdale, Perth, Western Australia 6105

Fax: +61 8 9353 2689 Tel: 1800 AVG AUS (284 287)

DISCLAIMER: Every care has been taken in the preparation of these instructions, which have been issued as a guide only. Compliance with the requirements of local Authorities is required at all times. These requirements may change from time to time. Always be aware of the local requirements. Subject to any statutory obligations and manufacturers warranties no liability can be accepted for any losses, consequential or otherwise which may arise or be said to have arisen from relying upon the contents of this installation instruction as to the fitness of any particular product for any particular purpose, use or application. The Australian Valve Group Pty Ltd reserves the right to modify designs and specifications and to withdraw and introduce products at any time without notice.