

Enware Aquablend® 2500 Megamix Thermostatic Mixing Valve with Thermal Flush Lift Lever

Installation Instructions

For use in Australia

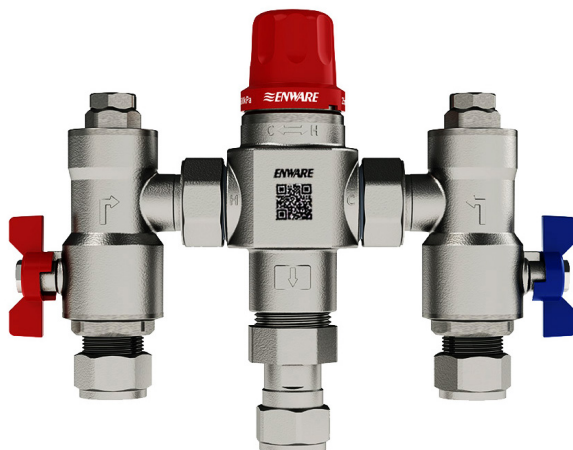

ATM725L

20mm Inlet with 20/25mm Outlet



100620_17 Jun 2026

1300 369 273 | info@enware.com.au
enware.com.au

ENWARE
A **WATTS** Brand

Aquablend 2500 Megamix Thermostatic Mixing Valve

The Enware Aquablend 2500 Megamix Thermostatic Mixing Valve is a high performance Thermostatic Mixing Valve suitable for a wide range of applications.

The valve is designed to comply with AS4032 - Thermostatic Mixing Valves.

PRODUCT FEATURES

- Complies with the requirements of AS4032 - Thermostatic Mixing Valves
- Provides high stability of mixed water temperature even under changing inlet conditions
- Ensures rapid shut down of mixed outlet flow in the event of hot or cold water supply failure
- Designed for quick and simple in-situ servicing
- Suitable for installation into AS3500 compliant systems with hot water temperature as low as 55°C
- Fitted with a tamper resistant temperature adjustment mechanism
- New Lift Lever activated Thermal Flush function allows controlled thermal flush to the TMV and warm water plumbing system

Enware reserves the right to change any product specification or information contained in this publication, at any time and without notice. Every care has been taken to ensure accuracy in the preparation of this publication which has been issued for guidance only. No liability can be accepted for any consequences which may arise as a result of its application.

Enware is a trademark of Enware Pty Ltd.



CONTENTS

Safety	page 4
Product Description	page 5
Recommended Pressures and Temperatures	page 7
Flow Sizing Graph	page 8
Installation	page 9
Commissioning of the Valve	page 11
Maintenance & Servicing	page 14
Thermal Flush	page 16
Troubleshooting	page 18
Spare Parts	page 20
Commissioning Report	page 21
Servicing Report	page 24
Warranty	page 26

SAFETY

The Enware Aquablend 2500 Megamix Thermostatic Mixing Valve is a high performance valve designed to give stable and dependable operation, provided it is installed, commissioned, operated and maintained as per the recommendations outlined in this manual. It should be noted however that this valve should not be considered as an alternative to adequate supervision and duty of care during its use and operation.

Note: When installed, the mixing valve, inlet controls, pipework and the surrounding area may become hot, which may cause burn injuries. Precautions should be taken to ensure that these surfaces cannot cause such injuries.

PRODUCT DESCRIPTION

The Aquablend 2500 Megamix TMV is available complete with inlet service fittings. The service fittings consist of isolating ball valves, strainers, pressure test points and non-return valves. The strainers can be serviced and cleaned without disturbing the installation (refer to Maintenance and Servicing section). The inlet service fittings also incorporate union type fittings enabling the thermostatic mixing valve to be removed from its installation without disturbing its pipework.

AQUABLEND 2500 MEGAMIX	
Product Code	ATM725L
Inlet	3/4" BSP male with compression nuts
Outlet Size	1" BSP male with 3/4" BSP adaptor
Dry Weight	3 kg
Finish	Nickel Plated

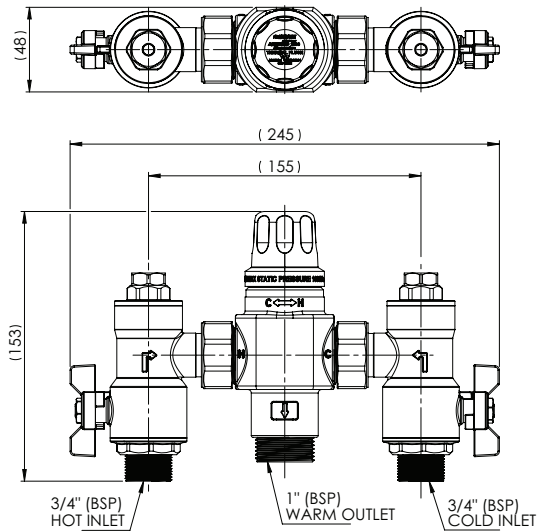

IMAGE 1

PRODUCT DESCRIPTION

Method of operation is illustrated in IMAGE 2 below:

Hot and cold water is supplied to each side of the valve respectively. The hot water enters through a port below the Piston, the cold water enters above the Piston. Upon entry the water begins to blend and enters the Mixing Tube. At this point the mixed water contacts the thermostatic wax Element. The Element will extend or contract to match the water temperature it is exposed to causing the Piston to move, thereby regulating the amounts of hot and cold water entering the valve. This thermostatic mechanism maintains the mixed water temperature at a constant temperature.

In the event of a sudden loss of the cold water supply the Piston will shut off the hot port thus stopping any flow through the valve. The valve will also shut down the cold supply if there is a hot water failure.

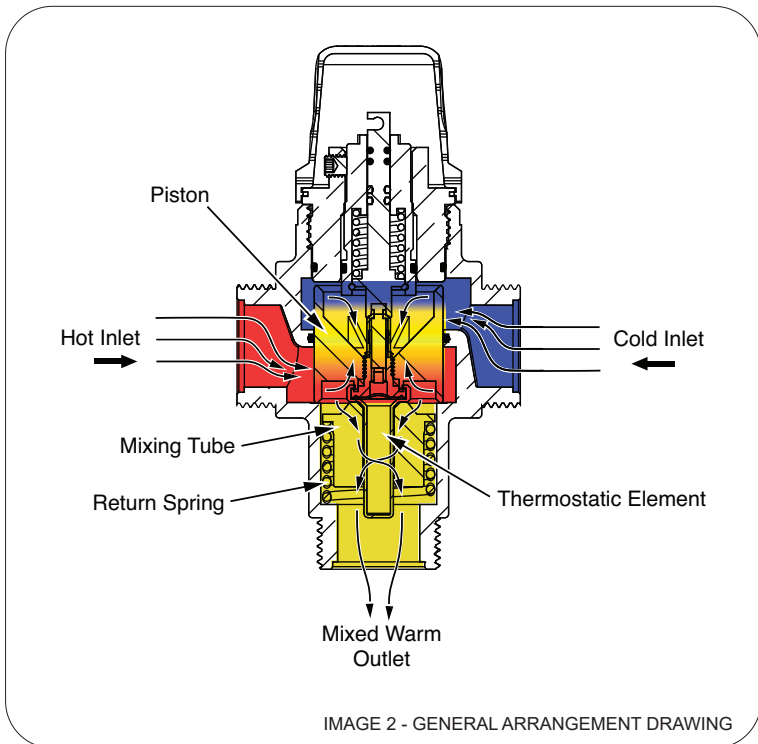

RECOMMENDED PRESSURES & TEMPERATURES

MIXED OUTLET TEMPERATURE		
Temperature Adjustment Range Set during installation/commissioning Factory set at 42°C		35 - 50°C (+/- 2 °C)
INLET TEMPERATURES		
Cold Supply	Minimum	5°C
	Maximum	30°C [^]
Hot Supply	Minimum	55°C
	Maximum	90°C
Hot to Mix Temperature Differential for Stable Operation		Minimum 10°C
Cold to Mix Temperature Differential for Stable Operation		Minimum 5°C
FLOW RATES		
Minimum	4 L/min	
Maximum	80 L/min @300kPa pressure loss as per flow sizing graph)	
DYNAMIC INLET PRESSURES		
Hot & Cold Inlet Pressures For optimum operation it is recommended that the hot and cold water supply pressures be balanced within +/- 10% for both static and dynamic pressures.	Minimum	20kPa
	Maximum	500kPa
STATIC INLET PRESSURES		
Hot & Cold Inlet Pressures For testing purposes/ system commissioning	Maximum	1600kPa
INLET PRESSURE RATIO		
$H - PL = H^1$ $C - PL = C^1$ $H^1 : C^1 = \text{Max } 10:1$ $C^1 : H^1 = \text{Max } 10:1$		H = Hot inlet pressure (dynamic) C = Cold inlet pressure (dynamic) PL = Pressure Loss

[^] Where cold inlet temperature may exceed recommended range due to seasonal variation, a 5°C temperature differential between the inlet cold supply and outlet mixed temperature setting must be maintained.

NOTE: Notwithstanding the above, compliance with the Plumbing Code of Australia (PCA) and AS/NZS 3500 must be maintained.

FLOW SIZING GRAPH

The Aquablend 2500 Megamix TMV is suitable for many applications. The Headloss Characteristic for Mixed Outlet Flow Rate versus Balanced Inlet Pressure is shown below in IMAGE 3. It is important that the valve is not oversized for its intended application.

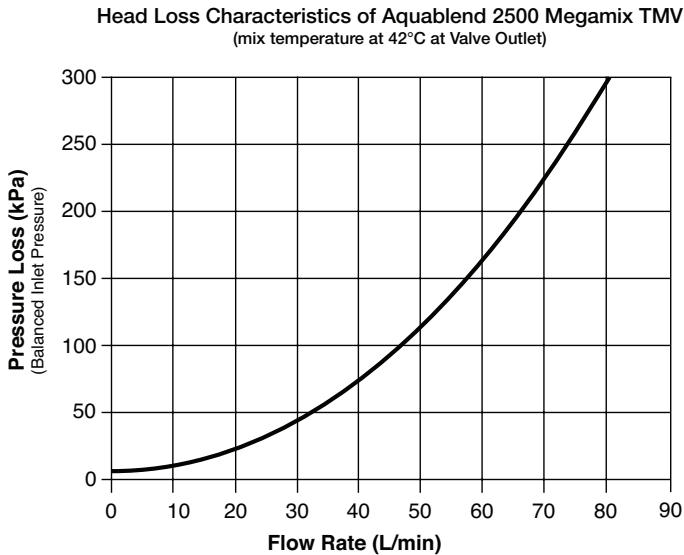

IMAGE 3 - Headloss Characteristics

It is important that the valve is sized such that the flow rates from the outlets are not less than those listed in AS3500.1- Section 3. The pipework between the valve and the system must be sized in accordance with AS3500.1 Section 3 and Appendix C to ensure the water velocity in the pipework is within the allowed limit.

If the valve is to be installed and operated under unequal inlet pressures the lower inlet pressure determines the outlet flow rate. However, for optimum performance and stability it is recommended that the valve be installed with balanced dynamic inlet pressures (+/- 10%).

INSTALLATION

The Aquablend 2500 TMV should be installed using the appropriate Standard, Code and legislation applicable to each state and following the details outlined in this section.

The Aquablend 2500 TMV must be installed by a licensed plumber, or where applicable, a licensed plumber who has undertaken TAFE training in Thermostatic Mixing Valves.

NOTE: To effectively control microbial hazards during system design, installation, commissioning and maintenance, the requirements outlined in AS/NZS3666 and local legislation shall be adhered to.

Inlets and outlet connections of the valve are clearly marked. The letters H and C cast into the valve body indicates the Hot and Cold Inlet respectively. An arrow cast into the body of the valve identifies the valve outlet direction.

If the valve is not installed correctly then it will not function correctly and may put the user in danger. It may also void the warranty of the valve.

Prior to the installation of the valve, the system must be checked to ensure that the system operating conditions fall within the recommended operating range of the Aquablend 2500 TMV as detailed on page 7 - recommended temperatures and pressures.

If the hot water supply temperature is greater than 90°C the valve may be damaged. A suitable temperature limiting valve must be fitted to the hot water supply, prior to the inlet fittings, if the temperature of the hot water will rise above 90°C.

It is also important that both of the inlet dynamic supply pressures are 500kPa or less. If either supply pressure exceeds 500kPa then a suitable pressure reducing valve must be fitted prior to the inlet control valve to reduce the pressure to an acceptable limit. For optimum performance from the valve it is recommended that the inlet pressures are balanced to within 10% of each other.

The water quality conditions should be checked to ensure they do not exceed the limits as listed in AS3500.4 Section 1.6. If they do exceed the limits it will be necessary to install a water softener or water treatment device.

INSTALLATION

NOTE: In some installations where certain types of faucet devices such as flick mixers and solenoid valves are used, the water pressure may be seen to spike outside that recommended for the valve during rapid shut off conditions created by these types of devices. Even if the spike only lasts a split second it is still considered to be outside the operating conditions, and may cause the valve to operate incorrectly. In the event that this does occur, measures must be taken to control the spike, such as an inline pressure reducing valves directly before the valve inlets.

To ensure that the mixing valve operates correctly it is necessary that the pipework is thoroughly flushed with clean water before the valve is installed. This will remove any physical contaminants from the pipework, ensuring trouble-free operation. During the flushing procedure care should be taken to prevent water damage occurring to the surrounding area.

The valve should be installed so it can be accessed easily for maintenance or servicing. The pipework to and from the valve must not be used to support the weight of the valve. Saddle clips or pipe support brackets must be used to mount the inlet control valves and TMV firmly to a wall or rigid support structure. The valve can be installed in a wall cavity, under a basin or on a wall, however it is essential that the mixing valve and inlet fittings are easily accessible for servicing. For concealed installations see the Enware Aquablend range of pre-plumbed cabinets.

TMV assembly is assembled loose in the packaging. Inlet to main body connection requires final tightening upon installation

During installation or servicing heat must not be applied near the mixing valve or inlet fittings, as this will damage the valve and inlet fitting internals. Failure to comply with this requirement will damage the valve and fittings. It will put the user at risk, and it will void the warranty of the valve.

COMMISSIONING OF THE VALVE

Upon completion of the installation, the valve should be tested and commissioned as per the procedure outlined below or as specified by the local authority. The entire procedure should be read through thoroughly prior to the commissioning of the valve. A calibrated digital thermometer having rapid response time with maximum temperature hold, a small flat bladed screwdriver, 3mm Allen key and the adjusting key (supplied with the Aquablend 2500 TMV) will be required to check and set the outlet mixed temperature of the valve.

Ensure all outlets that will be serviced by the valve have adequate warning signs posted to ensure that no outlet is used during commissioning.

Open the cold supply line to the valve, then open the hot supply line, ensuring there are no leaks.

Open the outlet that is serviced by the shortest length of pipe work between the mixing valve and outlet fixture.

Allow the mixed outlet to flow for at least 60 seconds to allow the temperature to stabilise before taking a temperature reading at the outlet with a digital thermometer. The flow rate should be at least 4L/min. The flow rate can be checked with the aid of a known size container and a stopwatch, or Enware Flow-Cup (ATMS1201). The temperature should be taken at the closest outlet served by the thermostatic mixing valve.

If the outlet temperature requires adjustment please follow steps below.

TEMPERATURE ADJUSTMENT

1. Using a small flat bladed screw driver, lever the Red Lock Shield (protective cover) off the valve. SEE IMAGE 5 (over page)
2. Loosen the temperature adjustment locking grub screw located on the hex of the top cap using 3mm Allen Key. SEE IMAGE 6
If the grub screw is not easily accessible, relocate the grub screw to the most accessible screw hole (3 screw holes are provided on the top cap for convenience). Leave the grub screw loose.

COMMISSIONING OF THE VALVE

3. Fit supplied key over the adjusting spindle. SEE IMAGE 7
 - To **increase** the mixed outlet temperature, rotate the spindle **anti-clockwise**.
 - To **decrease** the mixed outlet temperature, rotate the spindle **clockwise**
4. Allow the mixed outlet temperature to stabilize for 60 seconds and once again take a temperature reading. Repeat the procedure until the desired temperature has been reached.
5. Tighten the temperature adjustment locking grub screw. SEE IMAGE 6
6. Push the Red Lock Shield firmly back on to the top of the valve until it 'snaps' back into place.
7. Check the outlet temperature is stable over the full range of flow rates and that flow rate is adequate for the application.
8. Close the outlet.
9. The mixing valve is now set and locked.

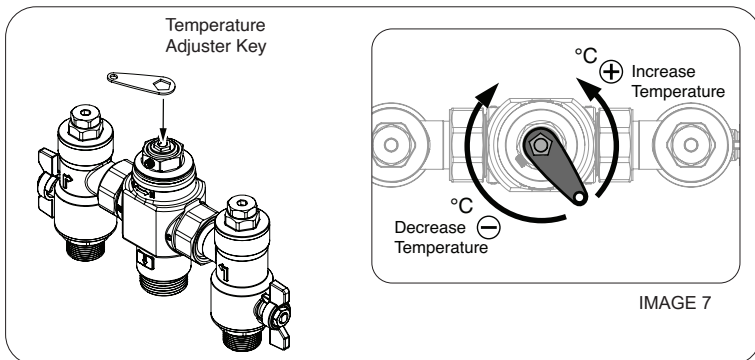
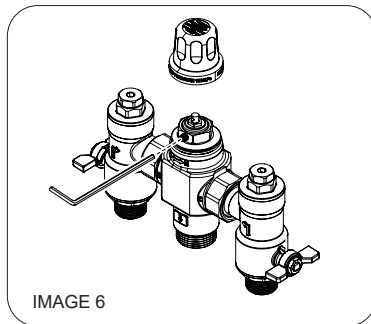
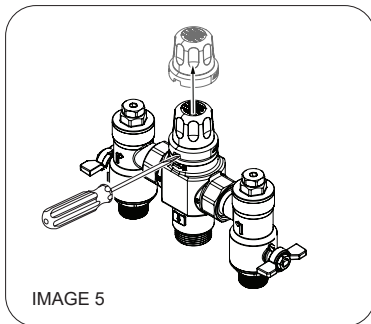

COMMISSIONING OF THE VALVE

SHUT DOWN TEST

Now that the mixing valve has been set and locked it is necessary to perform a shut down check. Allow the mixed water temperature to stabilise and note the outlet temperature. While holding a digital thermometer in the outlet flow, quickly isolate the cold water supply to the valve. The outlet flow should quickly cease flowing. The flow should be less than 0.1L/min following the isolation. Monitor the maximum outlet flow temperature, and record this on the Commissioning Report. The temperature should not exceed that allowed by the applicable standard or code of practice for each state. Restore the cold water supply to the valve. After the mixed water temperature has stabilised note the outlet temperature ensuring the outlet temperature has re-established.

Repeat the above test, except this time quickly isolate the hot water supply to the valve. The outlet flow should quickly slow to a trickle. The trickle should typically be less than 0.4L/min@500kPa down to less than 0.1L/min @100kPa following the isolation.

Restore the hot water supply to the valve. After the mixed water temperature has stabilised, measure and record the outlet temperature, ensuring the outlet temperature has re-established.

Ensure that all details of the Commissioning Report are completed and signed by the relevant signatories, and a copy is kept with the installer and owner of the premises.

The valve is now commissioned and it can be used within the technical limits of operation.

MAINTENANCE AND SERVICING

The Aquablend 2500 TMV will only require minimal preventative maintenance work to ensure it operates at its optimum level of performance. The valve should be commissioned and serviced annually, unless the installed conditions dictate more frequent servicing is necessary.

ANNUAL MAINTENANCE PROCEDURE

Every 12 months, the Aquablend 2500 TMV should be inspected and tested. The valve's external surfaces should be given a light wipedown. The valve and surrounding area should be inspected for leaks or water damage and action taken if required. Ensure a clean dry work area is available.

Cleaning the Strainers

Firstly isolate the hot and cold supplies to the mixing valve by closing the inlet ball valves. With a suitable spanner remove inlet fitting top cover then remove mesh strainer SEE IMAGE 8

Clean strainers with a suitable descaling solvent (such as CLR) diluted with water. Check for physical damage and thoroughly rinse with clean water. Strainers can then be re-installed into the valve and top cover replaced and tightened to a maximum torque of 15Nm into the inlet valve bodies.

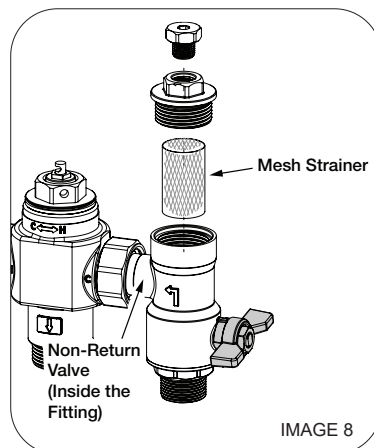

IMAGE 8

Non-Return Valve Operation

To check Non-Return Valve on the HOT inlet side, carry out the following steps:

1. Turn OFF the isolation tap on the HOT inlet only (COLD inlet must be open)
2. Open Test Port Cap on the HOT inlet side
3. Observe water level in the HOT inlet side test port.
4. If there is a rising water level this may indicate a fouled or faulty Non-Return Valve. If this is the case, inspect the non-return valve for damage or any debris, and replace Non-Return Valve if required.
6. Replace the test port cap on HOT inlet side ensuring it is tightly secured.
7. Turn the isolation tap on the HOT inlet back ON.
8. To check Non-Return Valve on the COLD inlet side, repeat steps above using the COLD inlet side.

Check that the test plug in the top of the inlet fittings are tight, and that there is no evidence of water leakage.

The valve must then be recommissioned as per page 11, including temperature adjustment and the shut down test.

If the valve fails to shut down or fails to maintain its set temperature, refer to the troubleshooting solutions outlined on page 18.

5-YEAR SERVICE

In addition to the Annual Maintenance, the valve piston O-ring and Thermostatic Element/ Piston Assembly must be replaced at intervals not exceeding 5 years from commissioning.

For re-greasing of O-rings, use food grade silicone based grease (e.g. Molykote 111, Clare FU5).

THERMAL FLUSH OPTION

The Aquablend 2500 TMV includes a built-in Thermal Flush feature allowing the facilities maintenance team or licensed service contactors to perform a controlled thermal flush to the TMV and warm water plumbing system.

NOTE: *The thermal flush procedure is optional and does not form part of commissioning and service requirements set out in AS4032.3*

Before commencing the thermal flush, a site-specific procedure must be implemented to control the risk of scalding. Hot water will run directly to the outlets fed by the Thermostatic Mixing Valve, and precautions shall be taken to prevent the chance of injury.

THERMAL FLUSH PROCEDURE

1. Turn OFF both hot and cold inlet valves to the TMV.
2. Remove the TMV's Red Lock Shield. (see IMAGE 5)

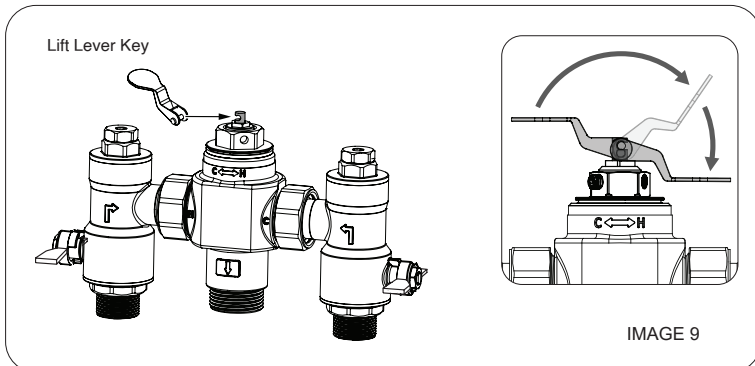
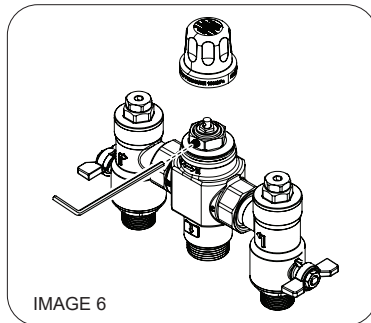
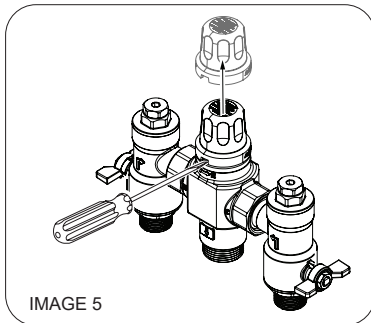

THERMAL FLUSH OPTION

3. Check that the temperature adjustment locking grub screw is tight. (Grub screw is located on the hex of the top cap - see IMAGE 6)
4. Hook the Lift Lever Key onto the thermal flush activation point located in the centre of the temperature adjustment screw on the valve's top cap. SEE IMAGE 9
5. Lift the lever up and over all the way until it comes to a stop. SEE IMAGE 9
6. Turn the hot water TMV inlet valve to the ON position.
7. Turn the tapware outlet to the ON position.
Note: full temperature hot water will flow from the tapware. Care must be taken to prevent scalding.
8. Once the required time set in the facility's Thermal Flush procedure has passed, turn the hot water TMV inlet valve to the OFF position.
9. Leaving the tapware outlet in the on position, turn the cold water TMV inlet valve to the ON position.
10. Slowly pull the Lift Lever Key back to the original position.
11. Turn the hot water TMV inlet valve to the ON position.
12. Check the outlet flow, making sure it is within the required temperature range.
13. Turn the tapware outlet off.
13. Re-fit the red lock shield to the TMV

NOTE: If the Red Lock Shield does not securely fit back to the top cap this indicates the thermal flush has not been disengaged. Repeat Steps 9-13

The Lock Shield cannot be securely replaced while the Lift Lever Key is in place.

TROUBLESHOOTING

FAULT/ SYMPTOM	CAUSE	RECTIFICATION
1. The desired mixed water temperature cannot be obtained or valve is difficult to set.	<ul style="list-style-type: none"> • Hot and cold supplies are fitted to the wrong connections • Valve contains debris • Strainers contain debris • Non-return devices are damaged • Top Cap and/or Piston O-rings are damaged 	<ul style="list-style-type: none"> • Refit the valve with Hot/ Cold supplies fitted to the correct connections • Clean the valve ensuring that all debris is removed and components are not damaged • Clean strainers ensuring debris is removed • Check non-return device is not jammed. Clean it if necessary • Check Top Cap & Piston O-rings for damage. Replace if necessary
2. The valve will not shut down	<ul style="list-style-type: none"> • The hot to mix temperature differential is not 10°C or greater. • The piston O-ring is damaged. • Valve body seat (Hot Seat) is damaged or fouled by debris • Cold seat (bottom surface of Top Cap) is damaged • Thermostatic element has failed • Plastic shuttle of Thermostatic element has been damaged by debris 	<ul style="list-style-type: none"> • Raise hot water temperature. • Replace piston O-ring • Clean seat using mild descaling solution • Replace top cap • Replace element
3. Mix temperature unstable	<ul style="list-style-type: none"> • Debris is fouling valve. • Flow rate below 4L/min. • Strainers are fouled. 	<ul style="list-style-type: none"> • Clean the valve ensuring that all debris is removed and components are not damaged • Rectify any pressure deterioration. • Clean strainers.
4. Mix temperature changing over time	<ul style="list-style-type: none"> • Inlet conditions (pressures or temperatures) are fluctuating. • Strainers contain debris 	<ul style="list-style-type: none"> • Install suitable pressure control valves to ensure inlet conditions are within those stated on page 7. • Clean strainers ensuring debris is removed

TROUBLESHOOTING

FAULT/ SYMPTOM	CAUSE	RECTIFICATION
5. Either full hot or cold flowing from outlet fixture	<ul style="list-style-type: none"> • Valve is incorrectly set. • Hot/Cold water has migrated to other inlet. • Refer also to fault/symptom 1 & 2 	<ul style="list-style-type: none"> • Adjust mix temperature between 35 - 50°C as required. • Replace faulty non-return valves
6. No flow from the valve outlet	<ul style="list-style-type: none"> • Hot or cold water failure. • Strainers are fouled 	<ul style="list-style-type: none"> • Valve functioning correctly. Restore inlet supplies and check mix temperature. • Clean strainers.
7. Flow rate reduced or fluctuating	<ul style="list-style-type: none"> • Valve or inlet fittings fouled by debris. • Dynamic inlet pressures are not within recommended limits. 	<ul style="list-style-type: none"> • Check valve and inlet fittings for blockages. • Ensure operating conditions are within specified limits and the dynamic inlet pressures are nominally balanced to within +/- 10%.
8. Mixed water temperature too hot or cold	<ul style="list-style-type: none"> • Valve has been tampered with • Valve incorrectly set • Inlet temperatures are not within specified limits 	<ul style="list-style-type: none"> • Readjust valve to required set temperature. • Readjust valve to required set temperature. • Ensure inlet temperatures are within the specified limits as listed on page 7.
9. Mixed water temperature not changing when the temperature adjuster is altered	<ul style="list-style-type: none"> • Return spring is missing • Thermostatic element has failed 	<ul style="list-style-type: none"> • Install return spring • Replace thermostatic element
10. Mixed water temperature adjuster difficult to move	<ul style="list-style-type: none"> • Adjuster at maximum mix temperature stop. • Valve piston into overstroke 	<ul style="list-style-type: none"> • Mixed water is at maximum temperature. No higher mix temperature adjustment is available • Wind adjuster out until set temperature required is achieved
11. Hot water flows into the cold water system or vice versa.	<ul style="list-style-type: none"> • Non-return valve has failed 	<ul style="list-style-type: none"> • Replace non-return valves
12. Valve is noisy	<ul style="list-style-type: none"> • Water velocity above velocity requirements of AS3500.1 Sec 3.4 	<ul style="list-style-type: none"> • Reduce water velocity.

SPARE PARTS

PART	REPLACEMENT TIME	PART NUMBER
5 Year Service Kit (includes O-rings, thermostatic element, top cap, red lock shield)	5 years	ATMS4001
O-Ring Kit	when required	ATMS4003

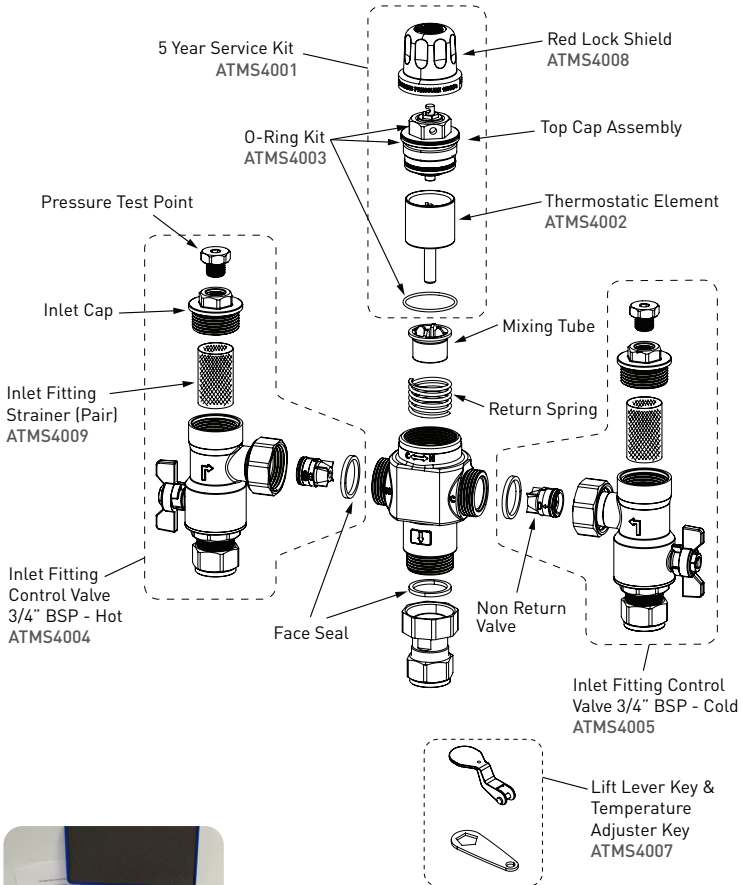

Aquablend Test Kit
ATMS1200



Pete's Plug
1/4" Test Point Adaptor
ATM1221



Wall Mounted Bracket
ATMS4010

COMMISSIONING REPORT

Enware Thermostatic Mixing Valve Commissioning Report For Thermostatic Mixing Valves use a separate sheet for each valve

Establishment					
Address					
Phone No		Contact			
Date		Work Order No.			
Make & Model of Hot Water Unit					
Hot Water	Pressure	kPa	Cold Water	Pressure	kPa
	Temp	°C		Temp	°C
Cold Water Supply via			Pressure Reducing Valve Fitted	YES/NO	
Make of Mixing Valve			Model No		
			Size		
Valve Location / Building					
Valve ID No.			Total No. of Mixing Valves on Site/ Building		
Total No. of outlets served by this valve	Baths	Basins	Showers		
Other outlet details					
Valve installed to requirements of					
The drawing & specification	The valve manufacture / supplier	The code of TMV's	The local water supply authority		
YES/NO	YES/NO	YES/NO	YES/NO		
If NO, give details and action taken					

COMMISSIONING REPORT

Test results (complete table on following page)		
Valve considered satisfactory for use	YES/NO	
If NO, state reason and action taken		
It is hereby certified that all the commissioning work has been carried out by the undersigned in accordance with local plumbing requirements for Thermostatic Mixing Valves		
Date initial service due:		(Maximum 12 months use)
Valve commissioned by:		
Signature Licensed Plumber	Lic/Cert No	
Business name of Plumbing Contractor		
Contractors Authority No	Date	

NOTE: A duplicate copy of this report is to be retained at the site for any inspection by authorised persons.

The following information is to be provided by site manager/owner:

Valve size and installation recommended by (name)		
Valve supplied by (name)		
Valve installed by (name)		
Date of installation:	Drawing No:	
Certificate of Compliance/Inspection No:	Dated:	
Service manual on site: YES/NO		
Report received by (name)		
Position		
Signature		Date:
For and on behalf of the client/site manager/owner		

COMMISSIONING REPORT

Test results

Valve location/building	
Room or area designation	
Work Order No	

Warm water outlet fixture No.	Name/type/size & location of outlet fixture (bath, shower, basin or other)	Flow rate of design warm water (L/sec)		Temp of warm water °C	
		1 outlet in use	** All req. outlets in use	1 outlet in use	** All req. outlets in use
1.					
2.					
3.					
4.					
5.					
6.					
7.					
8.					

Give details of brand and model designation. Commensurate with the design flow rate for the mixing valve.

NOTE: An accurate digital type thermometer is necessary for the temperature measurements.

Prescribed temperature range for warm water	°C to °C
Fail safe at both minimum and maximum design flow rates	PASSED/FAILED
Signature of licensed plumber	
Licence/Cert No	
Business name of plumbing contractor	
Contractor's authority No:	Date:

SERVICING REPORT

Enware Thermostatic Mixing Valve Servicing Report

use a separate sheet for each valve

Establishment			
Address			
Phone No		Contact	
Date		Work Order No.	
Make & Model of Hot Water Unit			
Mixing Valve Make:	Model No:		
	Size		
Valve Location / Building			
Valve ID No.		Total No. of Mixing Valves on Site/ Building	
Total No. of outlets served by this valve	Baths	Basins	Showers
Other outlet details			

Valve installed to requirements of:

The drawing & specification	The code of TMV's	The code of TMV's	The local water supply authority
YES/NO	YES/NO	YES/NO	YES/NO
If NO, give details and action taken			
Any current complaints concerning installation or operation reported or stated in previous report If YES, give details:			YES/NO
Particulars of service work carried out during this visit			
List of items replaced (and part numbers) during this visit:			
Warm water temp. at outlet	°C	Fail Safe Test	PASSED / FAILED
Valve considered satisfactory for further use			YES/NO
If NO, reason and action taken:			
Date next service due (12 months maximum):			

SERVICING REPORT

It is hereby certified that all the commissioning work has been carried out by the undersigned in accordance with local plumbing requirements for Thermostatic Mixing Valves		
Signature Licensed Plumber		Lic/Cert No
Business name of Plumbing Contractor		
Contractors Authority No		Date

NOTE: A duplicate copy of this report is to be retained at the site for any inspection by authorised persons.

The following information is to be provided by site manager/owner:

Valve size and installation recommended by (name)		
Valve supplied by (name)		
Valve installed by (name)		
Date of installation:	Drawing No:	
Certificate of Compliance/Inspection No:	Dated:	
Service manual on site: YES/NO		
Report received by (name)		
Position		
Signature		Date:

For and on behalf of the client/site manager/owner

Product Warranty Statement - WATTS AUSTRALIA

EFFECTIVE FROM 20 November 2023

This Warranty Statement applies to products supplied by Australian Valve Group Pty Ltd (ACN 068 227 270) (**AVG**) or Enware Pty Ltd (ACN 662 302 767) (**Enware**) (each of AVG and Enware, a Supplier) and installed within Australia.

Subject to the terms and conditions outlined in this Warranty Statement, each Supplier warrants to its customers that a product supplied by it (**Product**) will be free from all defects in material and workmanship under normal usage for the applicable Warranty Period (as set out in the Warranty Table below). The Warranty Period commences from the date of delivery of the relevant Product.

1. Conditions

The warranty provided under this Warranty Statement will not apply in respect of a Product (or any Product defect, fault or resulting damage) if:

- (a) the Product is not installed and maintained in accordance with the requirements of the applicable laws, standards and codes (including, without limitation to, the National Construction Code Volume Three – Plumbing Code of Australia, associated reference standards as applicable at the time and AS/NZS 3500);
- (b) the Product is not installed and maintained by a qualified technician in accordance with the relevant installation and operation manual and instructions; and
- (c) any Product defect, faulty or resulting damage arises from:
 - (i) failure by you or any other person to follow the relevant manual or instructions (relating to the handling, storage, installation, fitting, connection, adjustment, maintenance or repair of the Product) published or provided by the Supplier;
 - (ii) failure by you or any other person responsible for the fitting, installation, or other work on the Product to follow or conform to applicable laws, standards and codes (including, without limitation to, the AS/NZ 3500 set of Standards, all applicable State and Territory Plumbing Codes, the Plumbing Code of Australia and directions and requirements of local and other statutory authorities);
 - (iii) any parts or components not manufactured by the Supplier (or otherwise not authorised by the Supplier) are installed or combined with the Product, without the prior authorisation of the Supplier; or
 - (iv) any act or circumstance beyond our control including, without limitation to, accident, abnormal use, vandalism, fouling caused by foreign material, damage from adverse water conditions, chemical, acts of God, damage to buildings, other structures and infrastructure and loss or damage during transit or transportation of the Product, or any abuse, misuse, misapplication, improper installation or connection, or improper maintenance or alteration of the Product.

2. Make a claim

To make a claim under this Warranty Statement, you must notify the relevant Supplier in writing within 7 days of any alleged defect in the Product coming to your attention and provide the Supplier with proof of your purchase of the Product to the relevant Supplier:

- (a) If the Product is supplied by **AVG**, please contact AVG by telephone at 1800 284 287, or by email via its online portal <https://www.wattsau.com.au/support>.
- (b) If the Product is supplied by **Enware**, please complete the Product Service Request form (ENF091), which is available on request from our office (see contact details below), or online via <https://www.enware.com.au/warranty-service-form/>. All notifications and accompanying forms must be sent to Enware marked for the attention of Enware, 9 Endeavour Road, Caringbah NSW 2229. Enware can also be contacted by telephone (1300 369 273) or by email (info@enware.com.au).

On receipt of a notification from you of a claim under this Warranty Statement, the relevant Supplier may contact you requesting you provide reasonably additional evidence, information or details about your claim, or requiring that the relevant Product should be returned to the Supplier (in accordance with the Supplier's instructions) for inspection and testing.

Your failure to comply with any such request within a reasonable amount of time may result in your claim under this Warranty Statement being rejected.

3. Our responsibilities

(a) In the event that the Supplier is reasonably satisfied that there is a defect in the relevant Product within the applicable Warranty Period, the Supplier will, at its option, replace the Product, supply an equivalent product or repair the Product, free of charge. Your costs in making a warranty claim under this Warranty Statement, including any costs in relation to freight, collection, delivery and installation, are to be borne and paid by you. However, if in respect of a Product, it is indicated in the Warranty Table that labour support will be provided, and the Supplier is reasonably satisfied that a defect in the Product takes place during the period that labour support will be provided as indicated in the Warranty Table, the Supplier will bear the costs for delivery, repair and installation of the replacement Product (as applicable).

(b) TO THE EXTENT PERMITTED BY LAW AND SUBJECT TO PARAGRAPH 4 BELOW AND THE OPERATION OF THE AUSTRALIAN CONSUMER LAW:

(i) THE WARRANTY SET OUT IN THIS WARRANTY STATEMENT IS GIVEN EXPRESSLY AND IS THE ONLY WARRANTY GIVEN BY THE SUPPLIER WITH RESPECT TO THE RELEVANT PRODUCT;

(ii) THE SUPPLIER MAKES NO OTHER WARRANTIES, EXPRESS OR IMPLIED;

(iii) THE SUPPLIER HEREBY SPECIFICALLY DISCLAIMS ALL OTHER WARRANTIES, EXPRESS OR IMPLIED, INCLUDING BUT NOT LIMITED TO, THE IMPLIED WARRANTIES OF MERCHANTABILITY AND FITNESS FOR A PARTICULAR PURPOSE; AND

(iv) THE REMEDY DESCRIBED IN THIS WARRANTY STATEMENT SHALL CONSTITUTE THE SOLE AND EXCLUSIVE REMEDY FOR BREACH OF WARRANTY, AND THE SUPPLIER SHALL NOT BE RESPONSIBLE FOR ANY INCIDENTAL, SPECIAL OR CONSEQUENTIAL DAMAGES, OR LOST PROFITS OR THE COST OF REPAIRING OR REPLACING OTHER PROPERTY WHICH IS DAMAGED IF THE PRODUCT DOES NOT WORK PROPERLY.

4. Australian Consumer Law

This paragraph 4 applies if you are a 'Consumer' (as defined in section 3 of the Australian Consumer Law (**ACL**)) and the Product or services supplied to you falls within the goods or services which, for the purposes of the ACL, are of a kind ordinarily acquired for personal, domestic or household use or consumption.

The Products and services provided by the Supplier come with guarantees that cannot be excluded under the ACL, and noting in this Warranty Statement should be interpreted as attempting to exclude, restrict or modify such guarantees or your rights under the ACL. For major failures with any services, you are entitled:

(c) to cancel your service contract with us; and

(d) to a refund for the unused portion, or to compensation for its reduced value.

You are also entitled to choose a refund or replacement for major failures with Products. If a failure with the Product or a service does not amount to a major failure, you are entitled to have the failure rectified in a reasonable time. If this is not done you are entitled to a refund for the Products and to cancel the contract for the service and obtain a refund of any unused portion. You are also entitled to be compensated for any other reasonably foreseeable loss or damage from a failure in the Products or service'.

5. Warranty table

*the applicable period commences on the date of delivery of the Product.

PRODUCT GROUP	PRODUCT SERIES CODES	WARRANTY PERIOD (YEARS)*	LABOUR SUPPORT (YEARS)*
Aquablend Thermostatic Mixing Valves and Spare Parts	ATM, ATMV	5	5



A WATTS Brand

1300 369 273
info@enware.com.au
enware.com.au