

Trough Mounted Rubber Guard Bubbler Push Button

Installation and Maintenance Instructions

BUB705RB



technical data

Inlet Connection	1/2" BSP (15mm)
Recommended Working Pressure	100 - 500 kPa
Recommended Temperature Range	5 - 30 °C
Operating Temperature Range	0 - 50 °C

Enware products are to be installed in accordance with the Plumbing Code of Australia (PCA) and AS/NZS3500. Installations not complying with PCA and AS/NZS 3500 may void the product and performance warranty provisions.

Reference should also be made to the Australasian Health Facility Guidelines (AHFG), ABCB and Local Government regulations when considering the choice of, and the installation of these products.

This product must be installed and commissioned by a qualified plumber.

For use with potable water only.

NOTE: Enware Australia advises:

1. Due to ongoing Research and Development, specifications may change without notice.
2. Component specifications may change on some export models.

I00575_20 Jan 2024

1300 369 273 | info@enware.com.au | enware.com.au

ENWARE
A WATTS Brand

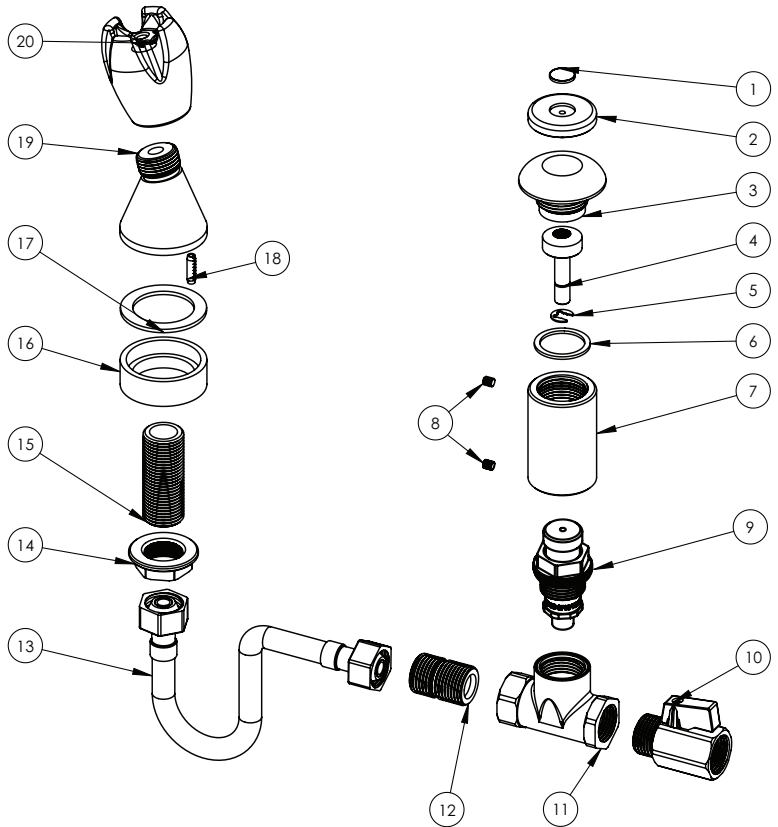

- 1 Indicator button
- 2 Push button
- 3 Base
- 4 Push button spindle
- 5 Circlip
- 6 Fibre washer
- 7 Connector
- 8 Grub screw socket 10-24UNCx3/16 SS304
- 9 SBA
- 10 Mini ball valve 1/2" MF
- 11 Stop tap body 1/2"
- 12 Tail 1/2" BSP
- 13 Flexible hose 1/2" 300mm
- 14 Back nut 1/2"
- 15 Tail 1/2" BSP
- 16 Spacer
- 17 Plastic washer
- 18 Anti-rotation pin
- 19 Outlet base
- 20 Rubber guard

installation

- All supply lines must be flushed thoroughly to remove debris prior to the installation of this product, as per AS/NZS 3500.1. Strainers (40 mesh) are recommended if debris is an ongoing problem.
- A pressure reduction valve may be required to comply with the recommended maximum supply pressure and/or balanced pressure requirements.

INSTALLATION

1. The fixture should be prepared with the relevant sized hole in the correct position as specified. On a stainless steel fixture, the push button assembly requires a 27mm diameter hole. The outlet requires 22mm diameter hole with another hole 4mm diameter for anti-rotation pin. SEE IMAGE 01
2. Unassemble the spring loaded basin assembly by unscrewing the top grub screw (8) from the connector (7) using a 3/32" Allen key, and then unscrewing the push button assembly (1,2,3,4,5,6) from the connector/valve assembly.
3. The push button assembly is fixed to the stainless steel fixture by sandwiching the fixture between the push button (3) and the connector (7). Put the push button assembly into the hole in the fixture and screw the push button into the connector/valve assembly positioned underneath.

If necessary adjust the position of the valve assembly to align with the inlet/outlet noting the direction of the flow. (arrow marked on the valve body.) SEE IMAGE 02 & 03

4. Ensure that the valve assembly is not over-tightened into the connector, as this may cause the valve to leak. There should be some free play (maximum 1mm) between the push button spindle (4) and the top of the spring loaded valve or SBA (9). Adjust as necessary by loosening the bottom connector grub screw and unscrewing the valve assembly out from the connector.
5. When set correctly tighten both the top and bottom grub screws (8) to secure the complete assembly.
6. The flow regulator ball valve (10) should be screwed onto the inlet of the tap body (11) using thread sealant.
7. Fit basin outlet (15,18,19,20) with plastic washer (17) to fixture, fit spacer (16) and back nut (14) from underneath. Tighten back nut with a spanner to fix the outlet in place.

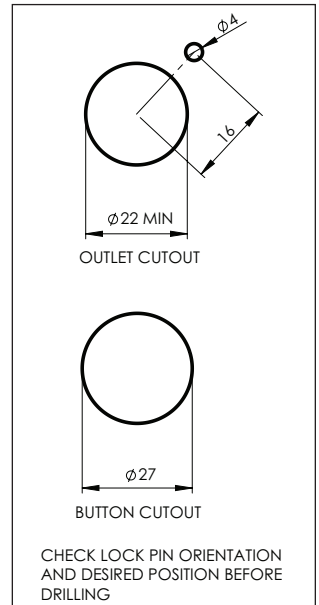

IMAGE 01

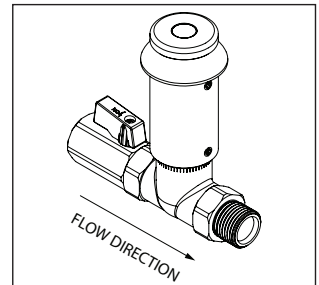

IMAGE 02

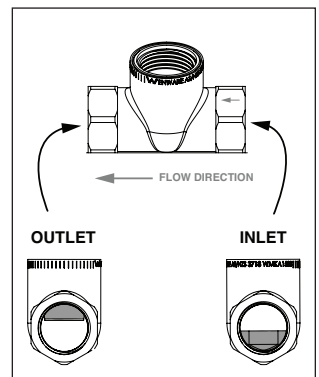

IMAGE 03

-
8. The flexible hose (13) is used to make the connection from the valve to the drinking bubbler outlet. Ensure that the internal seals are located in each flexible connector nut and tighten accordingly.
 9. Complete the inlet water connection to the valve (10) including the installation of an isolation valve prior to the valve assembly. Consider the ease of removal of the valve and for example use a connector nut rather than standard threaded fittings.
 10. Open the flow regulator ball valve (10) slightly and with the water supply on, test the unit for satisfactory operation, ensuring that there is sufficient travel in the push button (2) to fully activate the valve.
 11. Use the flow regulator (10) to regulate the flow from the outlet so as to confine the water stream within the drinking bubbler/basin profile.
 12. Self closing basin assemblies should turn off water immediately when the push button is released.

maintenance

CLEANING

Enware products should be cleaned with a soft damp cloth using only mild liquid detergent or soap and water. Do not use cleaning agents containing a corrosive acid, scouring agent or solvent chemicals. Do not use cream cleaners, as they are abrasive. Use of unsuitable cleaning agents may damage the surface. Any damage caused in this way will not be covered by warranty.

SPRING ACTION SBA

It is recommended that the spring action be periodically serviced. As a guide, every 6 months the spindle should be cleaned and re-greased, and the handle insert and other components checked for tightness. The servicing interval will vary depending on the frequency of use of the product, water quality and the general environment.

If the components inside the SBA are worn or damaged, replace the SBA or use the service kit to replace components.

CLEANING AND LUBRICATING THE SPINDLE

The spring action can be maintained by simply cleaning and lubricating the spindle (piston) using a silicon- based lubricant approved for potable water. This can be done without turning off the water supply.

1. Pull out the piston (the top part) of the SBA and wipe off any excess grease. SEE IMAGE NEXT PAGE
2. Clean the two small o-rings. Replace them if necessary, and re-grease them.
3. Push the piston back into the SBA.

REPLACING THE SBA

1. Shut off water supply and remove the top assembly.
2. Use a suitable spanner (26mm) and unscrew the SBA from the tap body. Make sure the seal o-ring is not left on the seat of the body and the old red fibre washer is also removed.
3. Replace with a new SBA.
4. Turn on water supply.
5. Depress the piston to start water flow. Release the piston to stop the flow and check for leakage. If a leak is present refer to Troubleshooting to identify cause of leakage and rectify before proceeding.

SERVICING THE SBA WITH SERVICE KIT

1. Pull the piston assembly out from the SBA and remove the 2 piston o-rings.
2. Use a spanner to unscrew bottom inlet port, remove spring and stainless steel ball in the port.
3. Insert a small screw driver in centre hole of the ball seating washer and remove the ball seating washer by levering it out.
4. Clean all brass and chrome components. Remove any debris or scale, especially on the piston, spindle and in the dome. Use a diluted solution of CLR for cleaning if necessary. Check all brass components for wear or damage.
5. Lightly grease the two small piston o-rings with a silicon based, potable water approved grease (e.g. Hydroseal Tap Lubricant or Molykote111) and fit the two o-rings to the piston.
6. Now reassemble the SBA with new components from Service Kit. Place the ball seating washer, ball and spring back in the bottom inlet port, and tighten up the bottom inlet port to the SBA. Refit the seat o-ring and seating washer. Push the piston into the SBA.

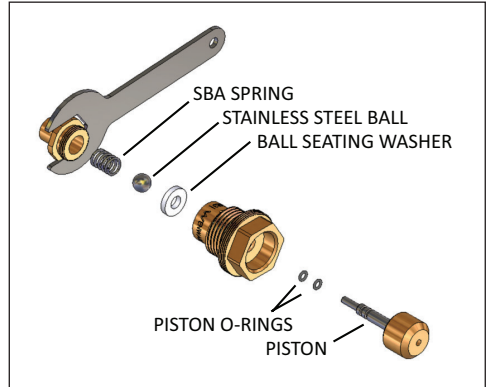

IMAGE 05

troubleshooting

PROBLEM	CAUSE	RECTIFICATION
Water leaking from outlet	Push button assembly screwed too tightly into connector.	Re-Adjust connector as per top assembly installation instructions
Water dripping and does not shut off	SBA spindle has debris caught in the mechanism.	Remove SBA and inspect. Remove debris and/or replace SBA if damaged. Install an inline strainer.
Water runs constantly from basin outlet	SBA seating washer damaged or spring broken	Dismantle and clean or replace SBA.
	Piston jammed in open position	Remove piston from SBA. Clean piston assembly
Water is leaking from spindle	O-ring on SBA is worn or damaged	Dismantle and clean piston from SBA. Replace SBA.
Water is not flowing from tap	Water turned off.	Turn water on.
Poor water flow from outlet	Aerator / Flow control or SBA is blocked by debris.	Remove flow control or SBA and clean debris. Install an inline strainer.
Push Button hard to operate	Water pressure too high	Adjust working pressure to that recommended
Push button feels too loose	Push button assembly screwed out too far Push button assembly incorrectly adjusted	Re-Adjust connector as per top assembly installation instructions
Spring action does not move	Piston in SBA is seized	Clean piston and piston o-rings, and re-grease. Use SBA service kit BUB289. (See service and maintenance)

spare parts

PART	ENWARE SALES CODE
SBA – Spring Action Lever/ Push Button	BUB260L
Spring action SBA service kit Includes 2x piston o-rings, 1x spring, 1x light spring, 1x ball bearing, 1x ball seating washer, 1x seat o-ring, 1x red fibre washer	BUB289
Replacement push button assembly	DET790
Replacement bubbler rubber guard	BUB734

product warranty statement - WATTS AUSTRALIA

Effective 27 October 2023

This Warranty Statement applies to products supplied by Australian Valve Group Pty Ltd (ACN 068 227 270) (**AVG**) or Enware Pty Ltd (ACN 662 302 767) (**Enware**) (each of AVG and Enware, a Supplier) and installed within Australia.

Subject to the terms and conditions outlined in this Warranty Statement, each Supplier warrants to its customers that a product supplied by it (**Product**) will be free from all defects in material and workmanship under normal usage for the applicable Warranty Period (as set out in the Warranty Table below). The Warranty Period commences from the date of delivery of the relevant Product.

1. Conditions

The warranty provided under this Warranty Statement will not apply in respect of a Product (or any Product defect, fault or resulting damage) if:

- (a) the Product is not installed and maintained in accordance with the requirements of the applicable laws, standards and codes (including, without limitation to, the National Construction Code Volume Three – Plumbing Code of Australia, associated reference standards as applicable at the time and AS/NZS 3500);
- (b) the Product is not installed and maintained by a qualified technician in accordance with the relevant installation and operation manual and instructions; and
- (c) any Product defect, faulty or resulting damage arises from:
 - (i) failure by you or any other person to follow the relevant manual or instructions (relating to the handling, storage, installation, fitting, connection, adjustment, maintenance or repair of the Product) published or provided by the Supplier;
 - (ii) failure by you or any other person responsible for the fitting, installation, or other work on the Product to follow or conform to applicable laws, standards and codes (including, without limitation to, the AS/NZ 3500 set of Standards, all applicable State and Territory Plumbing Codes, the Plumbing Code of Australia and directions and requirements of local and other statutory authorities);
 - (iii) any parts or components not manufactured by the Supplier (or otherwise not authorised by the Supplier) are installed or combined with the Product, without the prior authorisation of the Supplier; or
 - (iv) any act or circumstance beyond our control including, without limitation to, accident, abnormal use, vandalism, fouling caused by foreign material, damage from adverse water conditions, chemical, acts of God, damage to buildings, other structures and infrastructure and loss or damage during transit or transportation of the Product, or any abuse, misuse, misapplication, improper installation or connection, or improper maintenance or alteration of the Product.

2. Make a claim

To make a claim under this Warranty Statement, you must notify the relevant Supplier in writing within 7 days of any alleged defect in the Product coming to your attention and provide the Supplier with proof of your purchase of the Product to the relevant Supplier:

- (a) If the Product is supplied by **AVG**, please contact AVG by telephone at 1800 284 287, or by email via its online portal <https://www.wattsau.com.au/support>.
- (b) If the Product is supplied by **Enware**, please complete the Product Service Request form (ENF091), which is available on request from our office (see contact details below), or online via <https://www.enware.com.au/warranty-service-form/>. All notifications and accompanying forms must be sent to Enware marked for the attention of Enware, 9 Endeavour Road, Caringbah NSW 2229. Enware can also be contacted by telephone (1300 369 273) or by email (info@enware.com.au).

On receipt of a notification from you of a claim under this Warranty Statement, the relevant Supplier may contact you requesting you provide reasonably additional evidence, information or details about your claim, or requiring that the relevant Product should be returned to the Supplier (in accordance with the Supplier's instructions) for inspection and testing.

Your failure to comply with any such request within a reasonable amount of time may result in your claim under this Warranty Statement being rejected.

3. Our responsibilities

(a) In the event that the Supplier is reasonably satisfied that there is a defect in the relevant Product within the applicable Warranty Period, the Supplier will, at its option, replace the Product, supply an equivalent product or repair the Product, free of charge. Your costs in making a warranty claim under this Warranty Statement, including any costs in relation to freight, collection, delivery and installation, are to be borne and paid by you. However, if in respect of a Product, it is indicated in the Warranty Table that labour support will be provided, and the Supplier is reasonably satisfied that a defect in the Product takes place during the period that labour support will be provided as indicated in the Warranty Table, the Supplier will bear the costs for delivery, repair and installation of the replacement Product (as applicable).

(b) TO THE EXTENT PERMITTED BY LAW AND SUBJECT TO PARAGRAPH 4 BELOW AND THE OPERATION OF THE AUSTRALIAN CONSUMER LAW:

- (i) THE WARRANTY SET OUT IN THIS WARRANTY STATEMENT IS GIVEN EXPRESSLY AND IS THE ONLY WARRANTY GIVEN BY THE SUPPLIER WITH RESPECT TO THE RELEVANT PRODUCT;
- (ii) THE SUPPLIER MAKES NO OTHER WARRANTIES, EXPRESS OR IMPLIED;
- (iii) THE SUPPLIER HEREBY SPECIFICALLY DISCLAIMS ALL OTHER WARRANTIES, EXPRESS OR IMPLIED, INCLUDING BUT NOT LIMITED TO, THE IMPLIED WARRANTIES OF MERCHANTABILITY AND FITNESS FOR A PARTICULAR PURPOSE; AND
- (iv) THE REMEDY DESCRIBED IN THIS WARRANTY STATEMENT SHALL CONSTITUTE THE SOLE AND EXCLUSIVE REMEDY FOR BREACH OF WARRANTY, AND THE SUPPLIER SHALL NOT BE RESPONSIBLE FOR ANY INCIDENTAL, SPECIAL OR CONSEQUENTIAL DAMAGES, OR LOST PROFITS OR THE COST OF REPAIRING OR REPLACING OTHER PROPERTY WHICH IS DAMAGED IF THE PRODUCT DOES NOT WORK PROPERLY.

4. Australian Consumer Law

This paragraph 4 applies if you are a 'Consumer' (as defined in section 3 of the Australian Consumer Law (**ACL**)) and the Product or services supplied to you falls within the goods or services which, for the purposes of the ACL, are of a kind ordinarily acquired for personal, domestic or household use or consumption.

The Products and services provided by the Supplier come with guarantees that cannot be excluded under the ACL, and noting in this Warranty Statement should be interpreted as attempting to exclude, restrict or modify such guarantees or your rights under the ACL. For major failures with any services, you are entitled:

- (c) to cancel your service contract with us; and
- (d) to a refund for the unused portion, or to compensation for its reduced value.

You are also entitled to choose a refund or replacement for major failures with Products. If a failure with the Product or a service does not amount to a major failure, you are entitled to have the failure rectified in a reasonable time. If this is not done you are entitled to a refund for the Products and to cancel the contract for the service and obtain a refund of any unused portion. You are also entitled to be compensated for any other reasonably foreseeable loss or damage from a failure in the Products or service*.

5. Warranty table

*the applicable period commences on the date of purchase of the Product.

PRODUCT GROUP	PRODUCT SERIES CODES	WARRANTY PERIOD (YEARS)*	LABOUR SUPPORT (YEARS)
General Tapware, Spouts & Outlets- Chrome Plated	BUB	10	2