

# Care 721 Toilet S-Trap Raised Height

## Installation and Maintenance Instructions

CARE721BLUESC-RH-2



### technical data

Working Pressure Range	Min 50 kPa Max 500 kPa
Inlet Connection	1/2" BSP (DN15)
Water Inlet Connection Method	Bottom inlet
Outlet Connection	DN100 DWV PVC Pan Collar

Enware products are to be installed in accordance with the Plumbing Code of Australia (PCA) and AS/NZS3500. Installations not complying with PCA and AS/NZS 3500 may void the product and performance warranty provisions.

Reference should also be made to the Australasian Health Facility Guidelines (AHFG), ABCB and Local Government regulations when considering the choice of, and the installation of these products.

This product must be installed and commissioned by a qualified plumber.

For use with potable water only.



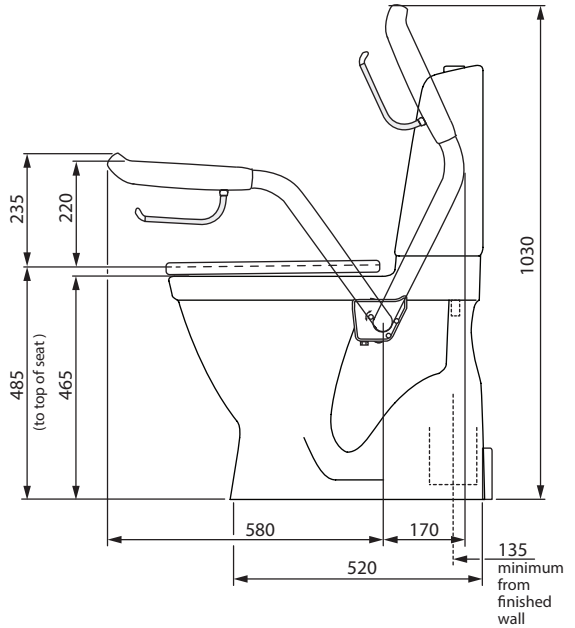
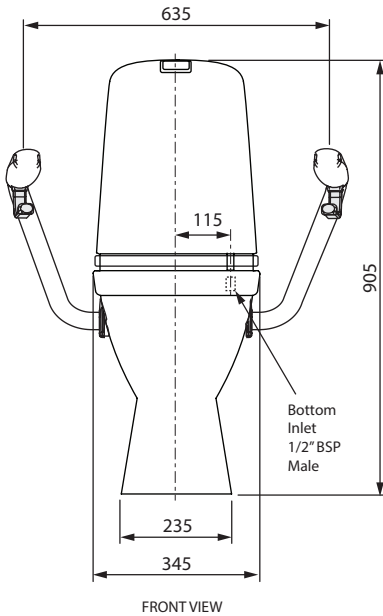
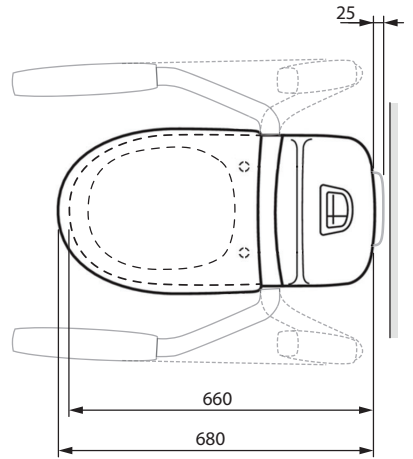

NOTE: Enware Australia advises:

1. Due to ongoing Research and Development, specifications may change without notice.
2. Component specifications may change on some export models.

# product description

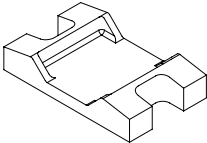
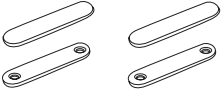

## PRODUCT CONTENTS

<p>Toilet [ CARE1546-RH ]</p>	
<p>Toilet Seat [ ENSEAT01-SC-DF-OB ]</p>	
<p>Support Arms [ CAREARM3/CAREARM3-XL/CAREARM3-XR ]</p>	
<p>Rear Cover [ CARE-S011 ]</p>	
<p>Pan Screws x 4 [ CARE-S012 ]</p>	
<p>Floor Mounting Bracket [ CARE-WCFFP ] ( Required for Opal Aged Care installations )</p>	
<p>Support plate and cover [ CARE-S034 ] ( Required for Opal Aged Care installations )</p>	

---

# installation

## 1. Determine Set Out For The Toilet Pan

Determine location and set out for the toilet.

Prepare waste outlet point according to one of the setout dimensions shown below

Connection to be used is a 100mm DWV Pan Collar.

### Institutional / Health Set Out

Set out typical for hospitals which allows for substantial air circulation and free coving

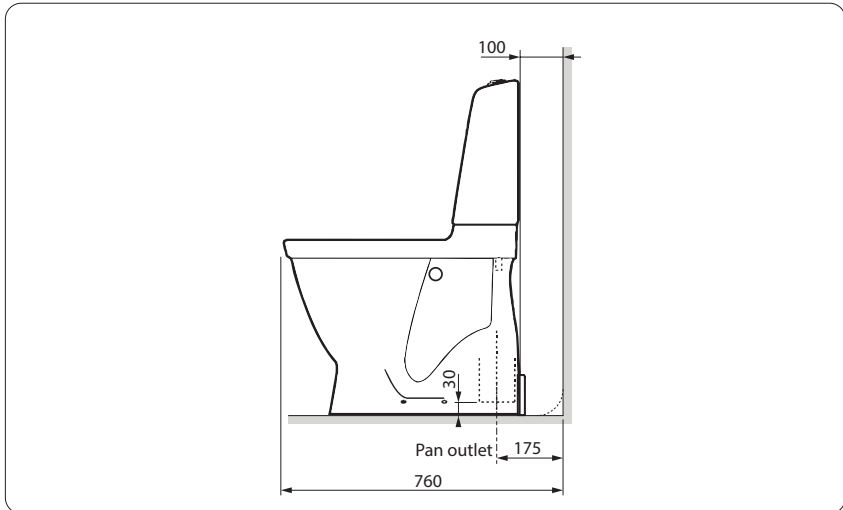

## Minimum Set Out

The minimum to still allow air circulation behind the WC pan

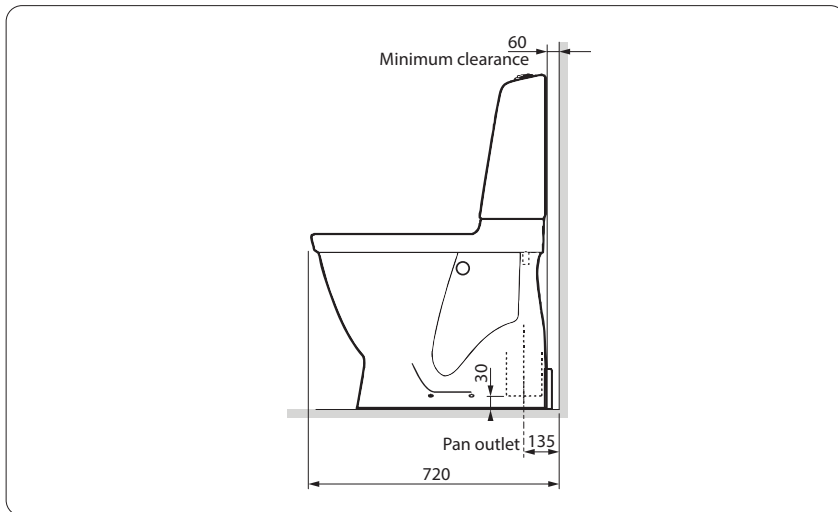

## 45° Corner Set Up

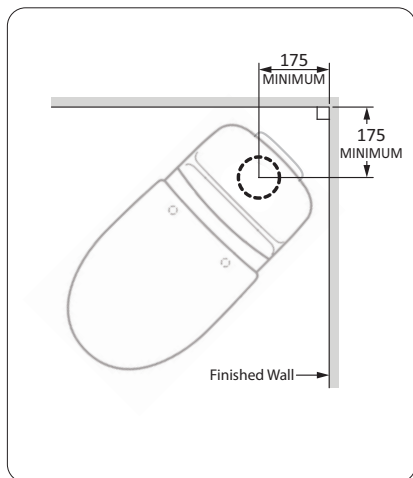

With no arm support system

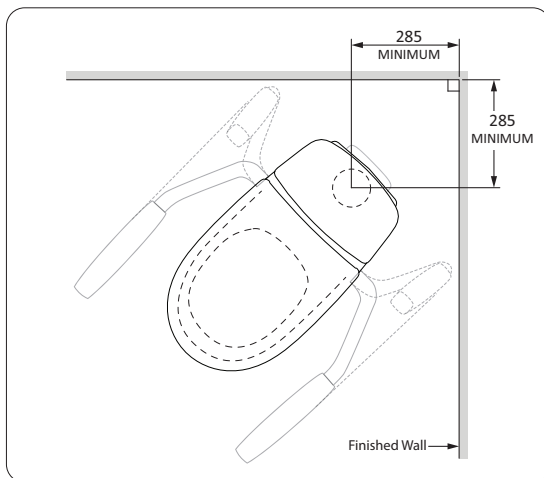

With arm support system

---

## 2. Determine Water Inlet Point

The water connection to the cistern inlet is a 1/2" BSP male, bottom inlet.

Looking from the front of the pan, it is located on the right hand side, on the bottom of cistern. Install a cistern tap in the vicinity.

## 3. Determine Floor Mounting Bracket Requirements

This installation information is a guide only. Appropriate fixing method must be determined by site-specific risk assessment.

Ensure the floor mounting requirements are appropriate according to the type and strength of the floor material, and the site risk assessment.

( Floor Mounting Bracket required for Opal Aged Care installations. )

**IMPORTANT** - For Toilets with Support Arms:

Due to the extra force applied to the toilet pan by support arms, the toilet pan must be fixed to the floor using stainless steel pan screws or floor mounting bracket.

Fixing the toilet pan with only silicone sealant is not an adequate method of fixing.

## 4. Fixing With Floor Mounting Bracket

### On Concrete Slab / Floor Before Waterproofing:

1. Position the bracket on the floor according to layout template. (See diagram below, and CARE-WCFFP bracket installation instructions for more details.)
2. Mark fixing bolt holes for the bracket on floor. (Do not drill bolt holes through the bracket yet.)
3. Where marked, install 4 threaded rods onto structural concrete slab or floor. Ensure threaded rods are long enough so that they will protrude at least 50mm from the finished floor.
4. Apply waterproofing as normal.

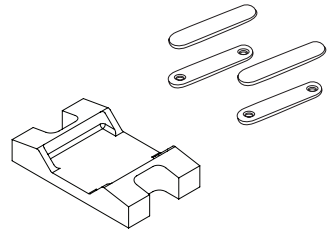

### After The Floor is Finished:

5. Once floor is finished, mark 4 bolt holes on bracket, and pre-drill the marked holes.
6. Fix the bracket onto floor using the threaded rods and matching washers and nuts.
7. Cut off any excess threaded rod.  
(... Continued next page)

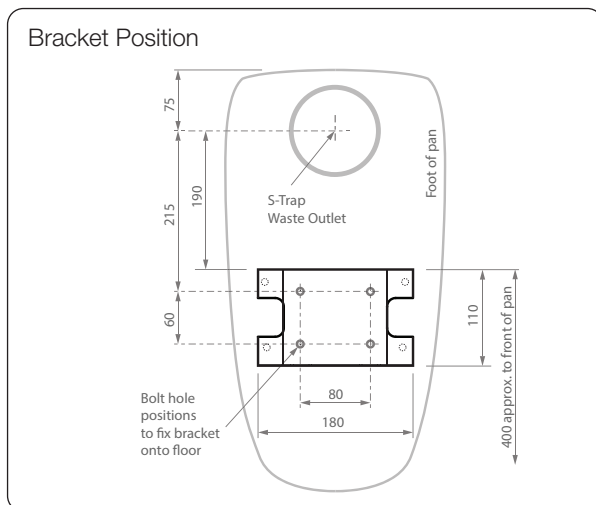
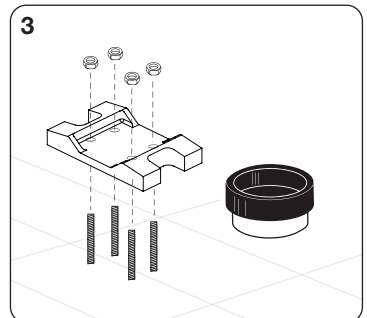
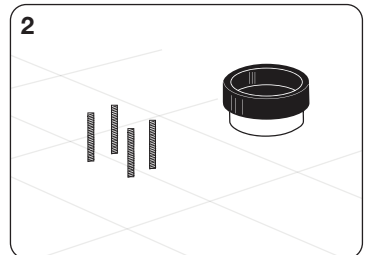
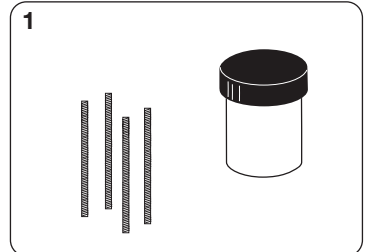

## Installing the Pan:

- WC pan should be bedded with silicone sealant. Ensure the floor surface and bottom surface of pan are clean and dry, free of dust, moisture and grease.

Place pan into position. Mark the profile of the foot of pan on the floor and remove pan. Apply silicone sealant to the marked profile of pan, and install the pan onto floor.

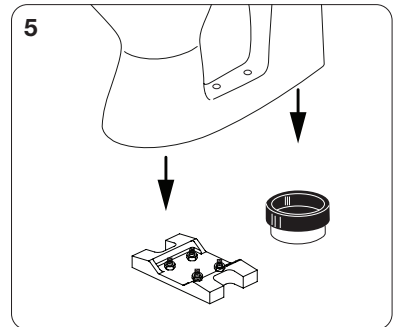
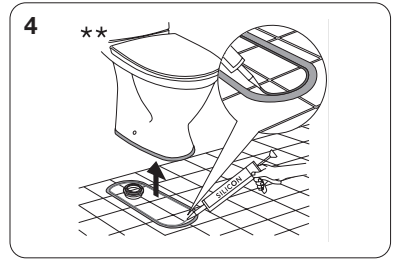

- Pre-drill pilot holes on the floor mounting bracket with 4mm drill.

Peel off the backing paper from metal support plates, and fit the plates onto toilet pan, ensuring the two screw holes align.

Fix the pan in place using four 12G x 50mm screws supplied to screw onto the floor mounting bracket. Hand tighten the screws, but do not over-tighten. (Over-tightening screws will cause the ceramic to crack.)

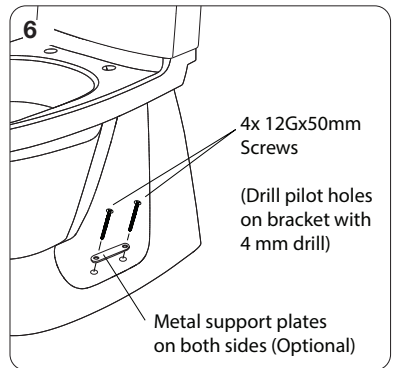

- Peel off paper backing of adhesive on white plate cover, and fit the cover over the metal support plate.

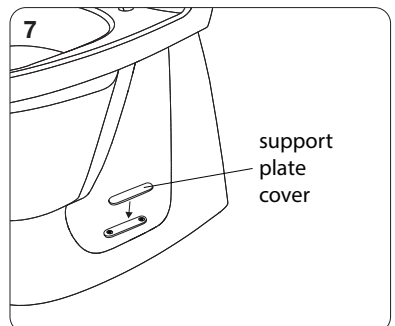

## 5. Water Inlet Connection



Flush the water supply line to ensure the line is clear, and connect water supply to the inlet connection of the cistern.

The inlet connection is flexible. Hold the inlet thread on the hex with a spanner when making the thread connection.

Turn water on and test connections.

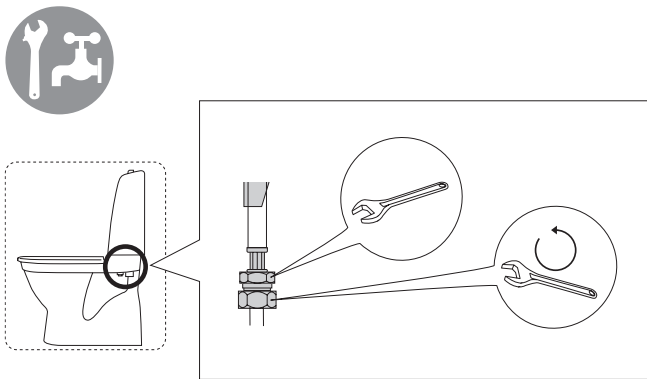
Test the flushing mechanism for correct operation, and inspect the plumbing connections for any leaks.



  

Operating pressure, fill valve 50 -1000 kPa  
Pressure test (water), fill valve.  
Max 1000 kPa

## 6. Install Rear Cover

After pan is levelled, water supply and waste are connected, and the pan is tested and visually inspected for any leaks, install the rear cover to plug the inspection hole. Use the round cover provided. Discard flat cover.

Apply silicone sealant inside and around the rear cover to create a thorough seal between the rear cover, pan and floor. Ensure no gap is left that can let any moisture to get through inside the base of the pan.

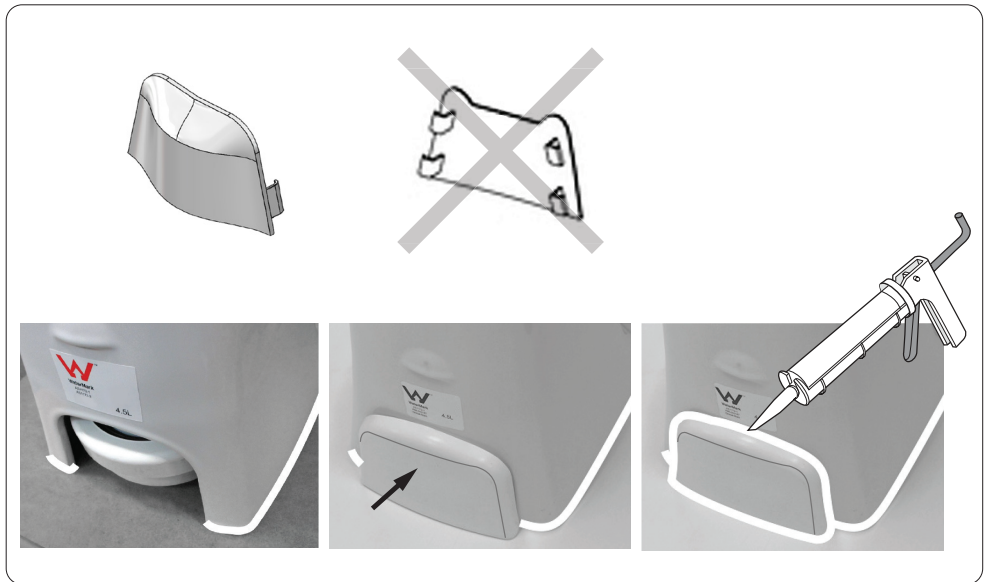

Do not use the toilet until the silicone bed has cured.

# access to cistern internal components

To access the internal components of the cistern, use a slotted screw driver to lever the full flush button out, and unscrew the middle fixing bolt. Next, unscrew the cistern fixing screws, using a T25 Torx key, and lift the ceramic shroud off the pan.

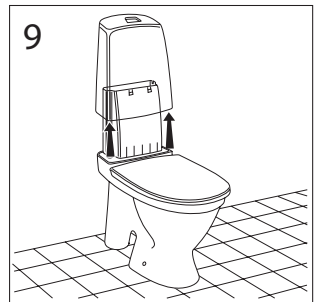
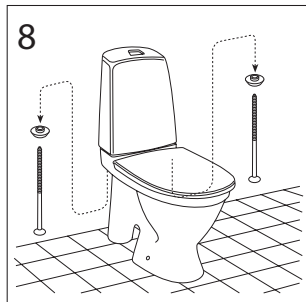
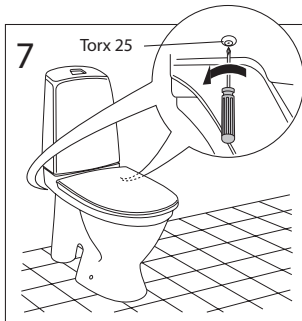
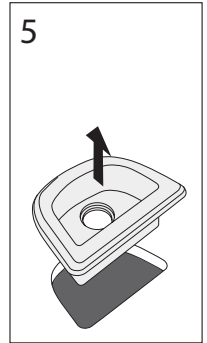
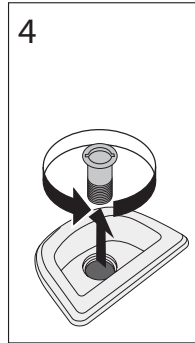
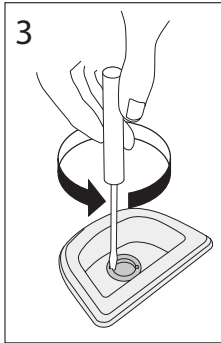
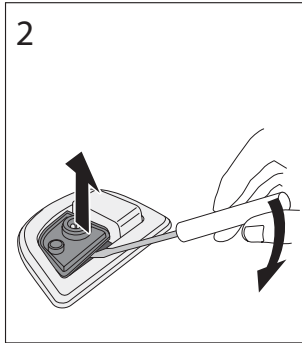
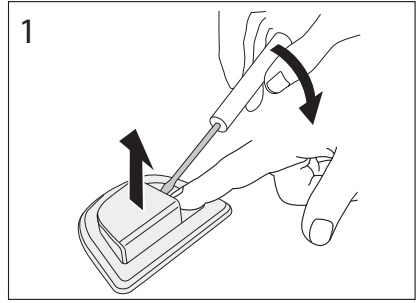
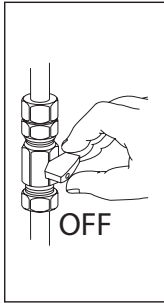

# maintenance

## Changing Outlet Washer

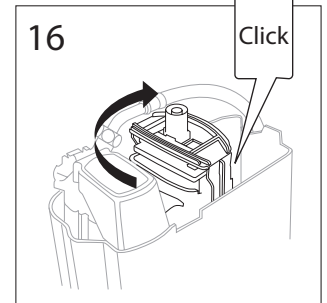
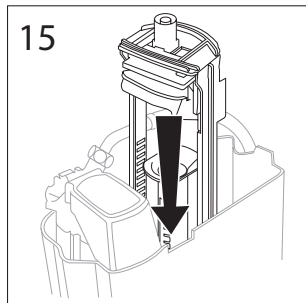
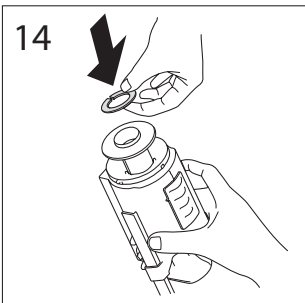
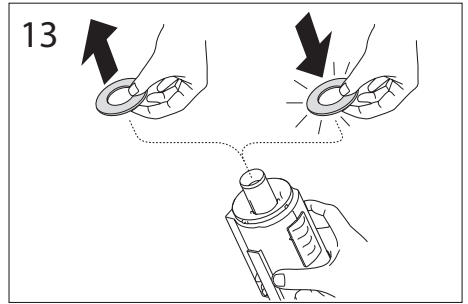
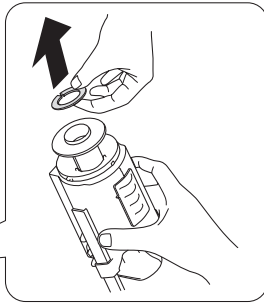
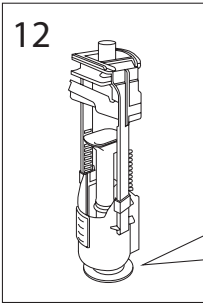
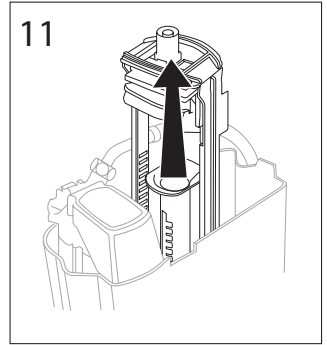
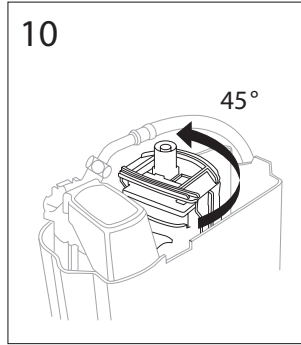
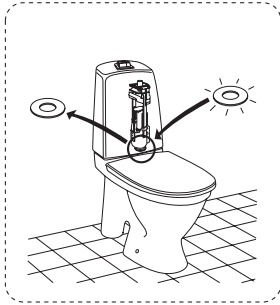

# Changing Flush Volume

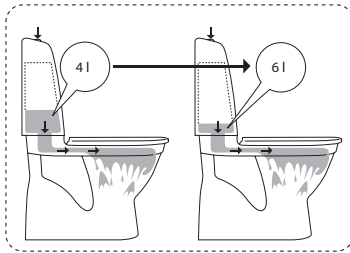

## Factory settings

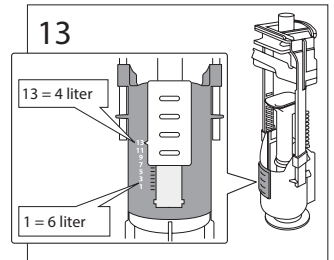
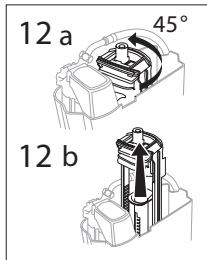
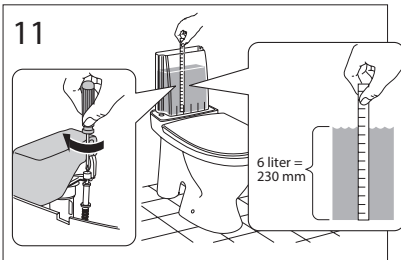
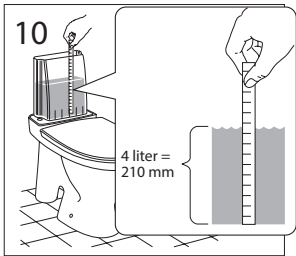
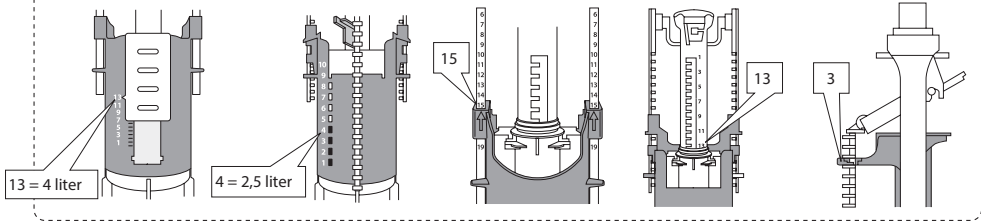

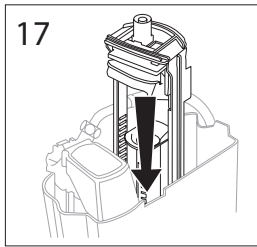
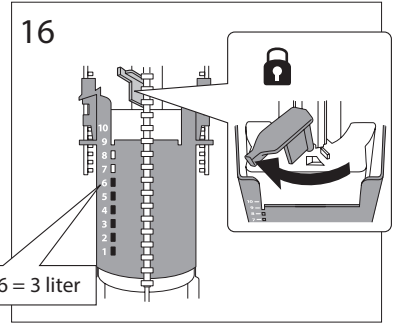
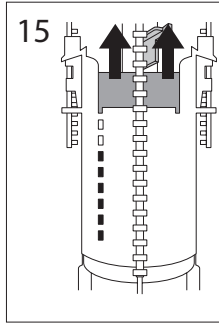
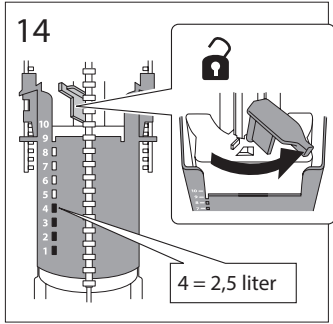

# Servicing Inlet Valve

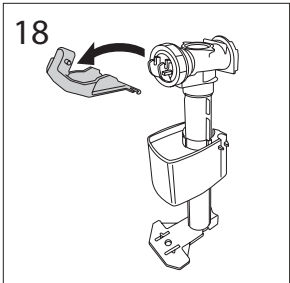
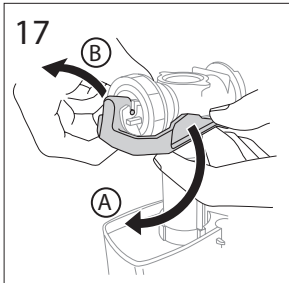
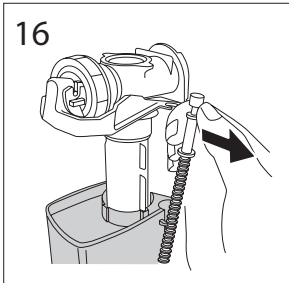
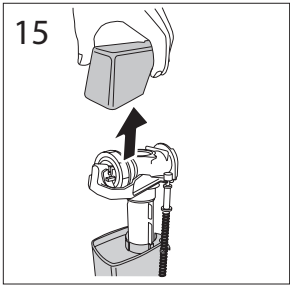
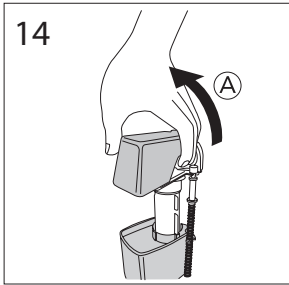
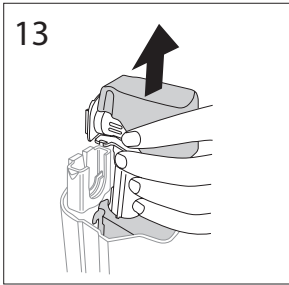
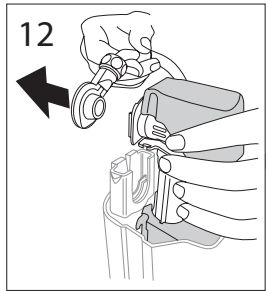
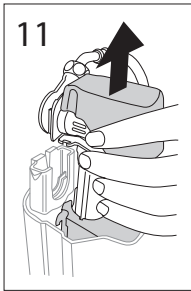
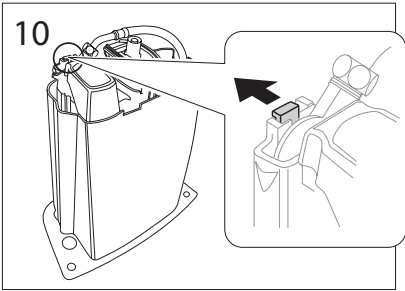

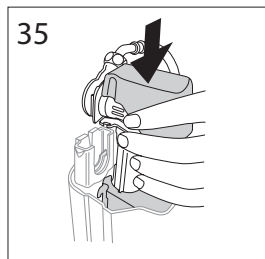
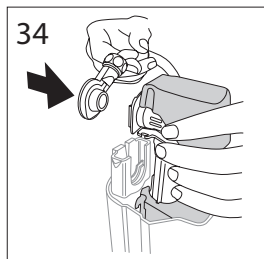
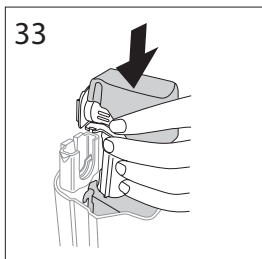
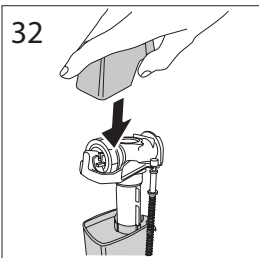
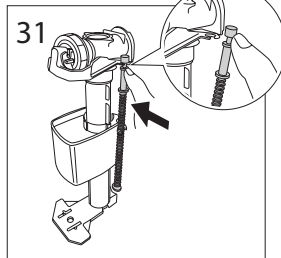
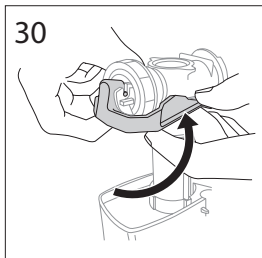
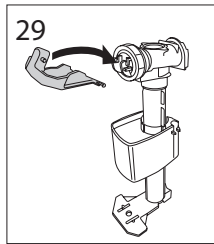
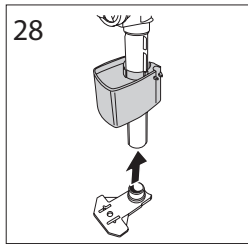
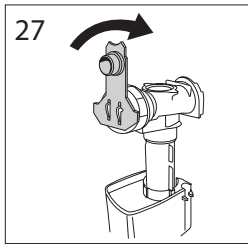
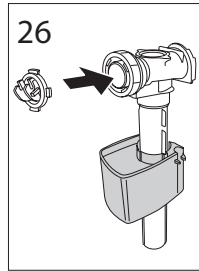
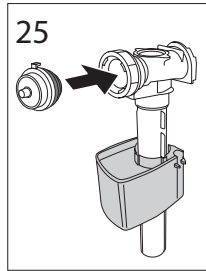
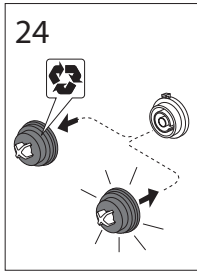
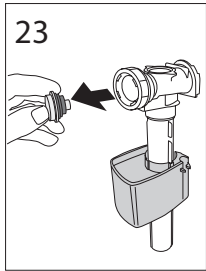
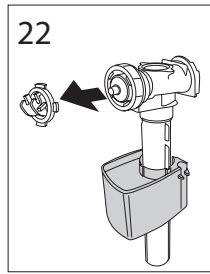
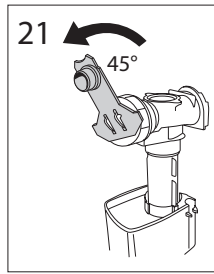
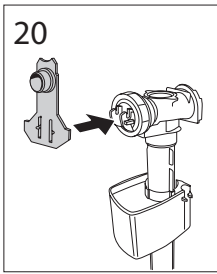
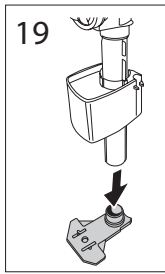

# Reinstalling Cistern Cover and Flush Button

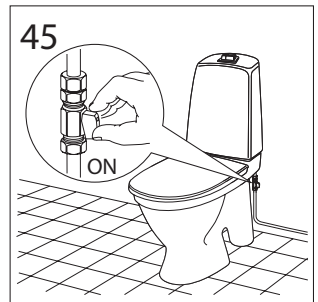
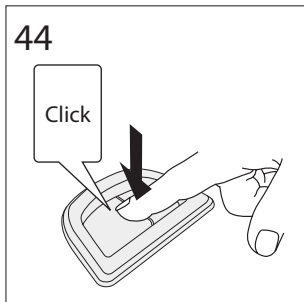
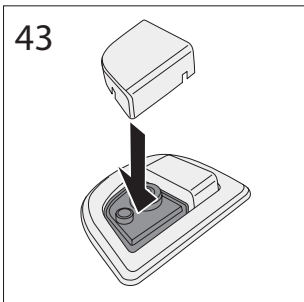
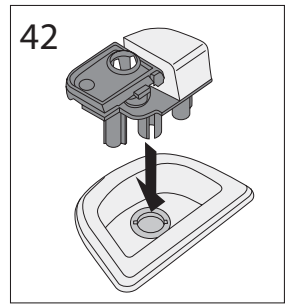
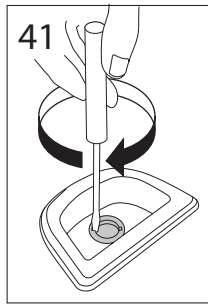
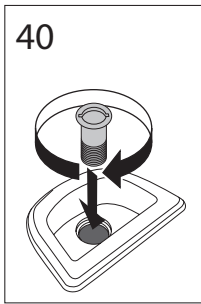
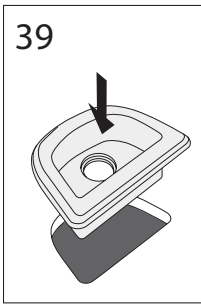
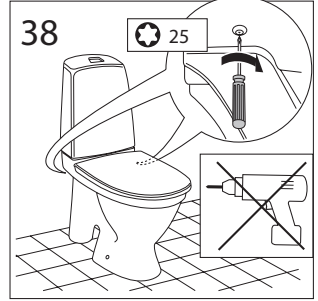
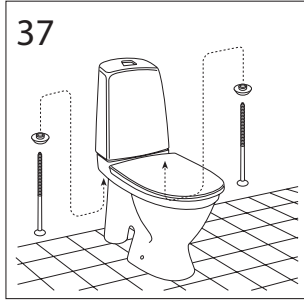

---

# **maintenance**

## **CLEANING**

- WC units have a glazed surface. Glazed surfaces are easy to keep clean and are resistant against most chemicals.
- Clean bowl regularly.
- Clean external surfaces regularly with a dry, soft cloth or a sponge. Alternatively clean with a soft damp cloth using only mild liquid detergent or soap and water, and wipe dry with a cloth.
- Cleaning utensils, which contain abrasive agents, such as steelwool and green scouring pads, must not be used. Strong abrasive materials can scratch the glaze and devoid it of its original qualities.
- Do not use cream cleaners, as they are abrasive.
- Strong acids such as hydrochloric acid or sulphuric acid, strong alkaline such as caustic soda, cleaning powders or pastes, and solvent chemicals must not be used.
- Avoid using cleaning agents on the flush button, instead, use hot water and soap and wipe dry with a cloth. This is because cleaning agents for porcelain are not intended for chrome parts/ plastics and can risk cracking the flush button if used frequently.
- Use of unsuitable cleaning agents may damage the surface. Any damage caused in this way will not be covered by warranty.
- Running WC units should be repaired immediately.
- Do not place chemical additives into the cistern tank as chemical additives can deteriorate the sealing rubber and valve components.

## troubleshooting

PROBLEM	CAUSE	RECTIFICATION
Toilet not flushing away	Flush volume too low	Increase flush volume
Drain blockages	Offset pan collars are used	Do not use offset pan collars that can impede outlet flow
Water constantly runs into bowl	Cistern fill level is too high	Adjust fill level on inlet valve to lower the water level below the overflow pipe
	Cistern Inlet valve failure	Replace inlet valve assembly
	Cistern Inlet valve is fouled by debris	Dismantle inlet valve and clean inlet valve seal
	Cistern outlet valve seal washer is worn or damaged	Replace outlet valve seal washer
	Cistern outlet valve is fouled by debris	Check outlet valve for any debris and clean
Water is leaking onto floor	Inlet hose or connections are leaking	Retighten connections or replace inlet hose
	Cistern fittings components are leaking	Check and retighten outlet, inlet and plug nuts
	Outlet connector broken or not engaged correctly	Uninstall pan and check outlet waste connector. Engage pan correctly, and/or replace connector.

# spare parts



DESCRIPTION	PRODUCT CODE	DESCRIPTION	PRODUCT CODE
1 Complete inner tank	CARE-S001	Family toilet seat grey soft close	CARE-S031
2 Cistern housing	CARE-S002	Care toilet seat - white	CARESEAT-WDF
3 Outlet flush valve	CARE-S003	Care toilet seat - grey	CARESEAT-GDF
4 Inlet fill valve	CARE-S004	23 Rear cover - round	CARE-S011
5 Inlet hose	CARE-S028	25 Floor mounting bracket	CARE-WCFFP
6 Inlet valve washer kit	CARE-S006	- Support plate and cover x 2	CARE-S034
7 Dual flush button raised	CARE-S007	- Toilet suite complete - no seat	CARE1546-RH
10 Pan screws kit	CARE-S012	- Care toilet seat - white	CARESEAT-WDF
11 Outlet valve seal gasket	CARE-S013	- Hinge fixing kit for Care toilet seat	CARE-S027
13 Cistern fixing kit	CARE-S015	- Care support arms	CAREARM3
14 Toilet seat blue with lid soft close	ENSEAT01-SC-DF-OB	- Care support arms with Right Hand Nursecall	CAREARM3-XR
Toilet seat white with lid soft close	CARE-S023	- Care support arms with Left Hand Nursecall	CAREARM3-XL
Toilet seat black with lid soft close	CARE-S024		
Family toilet seat white soft close	CARE-S032		





# product warranty statement - WATTS AUSTRALIA

EFFECTIVE FROM 20 November 2023

This Warranty Statement applies to products supplied by Australian Valve Group Pty Ltd (ACN 068 227 270) (**AVG**) or Enware Pty Ltd (ACN 662 302 767) (**Enware**) (each of AVG and Enware, a Supplier) and installed within Australia.

Subject to the terms and conditions outlined in this Warranty Statement, each Supplier warrants to its customers that a product supplied by it (**Product**) will be free from all defects in material and workmanship under normal usage for the applicable Warranty Period (as set out in the Warranty Table below). The Warranty Period commences from the date of delivery of the relevant Product.

## 1. Conditions

The warranty provided under this Warranty Statement will not apply in respect of a Product (or any Product defect, fault or resulting damage) if:

- (a) the Product is not installed and maintained in accordance with the requirements of the applicable laws, standards and codes (including, without limitation to, the National Construction Code Volume Three – Plumbing Code of Australia, associated reference standards as applicable at the time and AS/NZS 3500);
- (b) the Product is not installed and maintained by a qualified technician in accordance with the relevant installation and operation manual and instructions; and
- (c) any Product defect, faulty or resulting damage arises from:
  - (i) failure by you or any other person to follow the relevant manual or instructions (relating to the handling, storage, installation, fitting, connection, adjustment, maintenance or repair of the Product) published or provided by the Supplier;
  - (ii) failure by you or any other person responsible for the fitting, installation, or other work on the Product to follow or conform to applicable laws, standards and codes (including, without limitation to, the AS/NZ 3500 set of Standards, all applicable State and Territory Plumbing Codes, the Plumbing Code of Australia and directions and requirements of local and other statutory authorities);
  - (iii) any parts or components not manufactured by the Supplier (or otherwise not authorised by the Supplier) are installed or combined with the Product, without the prior authorisation of the Supplier; or
  - (iv) any act or circumstance beyond our control including, without limitation to, accident, abnormal use, vandalism, fouling caused by foreign material, damage from adverse water conditions, chemical, acts of God, damage to buildings, other structures and infrastructure and loss or damage during transit or transportation of the Product, or any abuse, misuse, misapplication, improper installation or connection, or improper maintenance or alteration of the Product.

## 2. Make a claim

To make a claim under this Warranty Statement, you must notify the relevant Supplier in writing within 7 days of any alleged defect in the Product coming to your attention and provide the Supplier with proof of your purchase of the Product to the relevant Supplier:

- (a) If the Product is supplied by **AVG**, please contact AVG by telephone at 1800 284 287, or by email via its online portal <https://www.wattsau.com.au/support>.
- (b) If the Product is supplied by **Enware**, please complete the Product Service Request form (ENF091), which is available on request from our office (see contact details below), or online via <https://www.enware.com.au/warranty-service-form/>. All notifications and accompanying forms must be sent to Enware marked for the attention of Enware, 9 Endeavour Road, Caringbah NSW 2229. Enware can also be contacted by telephone (1300 369 273) or by email ([info@enware.com.au](mailto:info@enware.com.au)).

On receipt of a notification from you of a claim under this Warranty Statement, the relevant Supplier may contact you requesting you provide reasonably additional evidence, information or details about your claim, or requiring that the relevant Product should be returned to the Supplier (in accordance with the Supplier's instructions) for inspection and testing.

Your failure to comply with any such request within a reasonable amount of time may result in your claim under this Warranty Statement being rejected.

## 3. Our responsibilities

(a) In the event that the Supplier is reasonably satisfied that there is a defect in the relevant Product within the applicable Warranty Period, the Supplier will, at its option, replace the Product, supply an equivalent product or repair the Product, free of charge. Your costs in making a warranty claim under this Warranty Statement, including any costs in relation to freight, collection, delivery and installation, are to be borne and paid by you. However, if in respect of a Product, it is indicated in the Warranty Table that labour support will be provided, and the Supplier is reasonably satisfied that a defect in the Product takes place during the period that labour support will be provided as indicated in the Warranty Table, the Supplier will bear the costs for delivery, repair and installation of the replacement Product (as applicable).

(b) TO THE EXTENT PERMITTED BY LAW AND SUBJECT TO PARAGRAPH 4 BELOW AND THE OPERATION OF THE AUSTRALIAN CONSUMER LAW:

- (i) THE WARRANTY SET OUT IN THIS WARRANTY STATEMENT IS GIVEN EXPRESSLY AND IS THE ONLY WARRANTY GIVEN BY THE SUPPLIER WITH RESPECT TO THE RELEVANT PRODUCT;
- (ii) THE SUPPLIER MAKES NO OTHER WARRANTIES, EXPRESS OR IMPLIED;
- (iii) THE SUPPLIER HEREBY SPECIFICALLY DISCLAIMS ALL OTHER WARRANTIES, EXPRESS OR IMPLIED, INCLUDING BUT NOT LIMITED TO, THE IMPLIED WARRANTIES OF MERCHANTABILITY AND FITNESS FOR A PARTICULAR PURPOSE; AND
- (iv) THE REMEDY DESCRIBED IN THIS WARRANTY STATEMENT SHALL CONSTITUTE THE SOLE AND EXCLUSIVE REMEDY FOR BREACH OF WARRANTY, AND THE SUPPLIER SHALL NOT BE RESPONSIBLE FOR ANY INCIDENTAL, SPECIAL OR CONSEQUENTIAL DAMAGES, OR LOST PROFITS OR THE COST OF REPAIRING OR REPLACING OTHER PROPERTY WHICH IS DAMAGED IF THE PRODUCT DOES NOT WORK PROPERLY.

## 4. Australian Consumer Law

This paragraph 4 applies if you are a 'Consumer' (as defined in section 3 of the Australian Consumer Law (**ACL**)) and the Product or services supplied to you falls within the goods or services which, for the purposes of the ACL, are of a kind ordinarily acquired for personal, domestic or household use or consumption.

The Products and services provided by the Supplier come with guarantees that cannot be excluded under the ACL, and noting in this Warranty Statement should be interpreted as attempting to exclude, restrict or modify such guarantees or your rights under the ACL. For major failures with any services, you are entitled:

- (c) to cancel your service contract with us; and
- (d) to a refund for the unused portion, or to compensation for its reduced value.

You are also entitled to choose a refund or replacement for major failures with Products. If a failure with the Product or a service does not amount to a major failure, you are entitled to have the failure rectified in a reasonable time. If this is not done you are entitled to a refund for the Products and to cancel the contract for the service and obtain a refund of any unused portion. You are also entitled to be compensated for any other reasonably foreseeable loss or damage from a failure in the Products or service\*.

## 5. Warranty table

\*the applicable period commences on the date of delivery of the Product.

PRODUCT GROUP	PRODUCT SERIES CODES	WARRANTY PERIOD (YEARS)*	LABOUR SUPPORT (YEARS)
Sanitaryware	CARE700 Series Toilet	2	1



1300 369 273  
info@enware.com.au  
enware.com.au