

# Secure Wall Mounted Sensor Tap - On/Off Demand - Ligature Resistant Basin Outlet

## Installation and Maintenance Instructions

DET5072A-CNBSN

ENMS135A



## technical data

Inlet Connection	15mm (1/2" BSP)
Recommended Working Pressure Range	100 - 500 kPa
Flow Rate (Laminar flow aerator supplied standard with spout)	8 L/min (3 Star WELS rating)
Maximum Hot Water Supply Temperature	70 °C
Power	24V transformer with 4.5m lead Input: 100-240V~50/60Hz Output: 24V DC 1.25mA
Power Consumption	Less than 10W
Sensor Min / Max Ambient Temperature	Minimum: -5 °C, Maximum: 50 °C
Sensor Protection Rating	IP67 for the front panel and sensor lens. No IP rating behind panel.
Sensor Range	20 - 100mm
Flow time*	Place hand in sensor range to activate. Place hand in sensor range again to stop. (On/Off Demand) Maximum of 45 seconds time out per activation. (Security Time Out)

\* Optional program settings are available on the following:

- Adjust Minimum Flow Time (Afterflow)
- Adjust Maximum Flow Time
- Adjust Sensor Range
- Purge Flush Running Time
- Purge Flush Period Frequency (from last activation)
- Mode – On /Off Demand or Active Sense



The optional settings are available at the time of ordering. Contact Enware for more details.

Enware products are to be installed in accordance with the Plumbing Code of Australia (PCA) and AS/NZS3500. Installations not complying with PCA and AS/NZS 3500 may void the product and performance warranty provisions.

Reference should also be made to the Australasian Health Facility Guidelines (AHFG), ABCB and Local Government regulations when considering the choice of, and the installation of these products.

This product is compliant with the Lead Free requirements of NCC Volume Three.

This product must be installed and commissioned by a qualified plumber.

For use with potable water only.

NOTE: Enware Australia advises:

1. Due to ongoing Research and Development, specifications may change without notice.
2. Component specifications may change on some export models.
3. Refer to warranty statement for warranty details - [www.enware.com.au/warranty](http://www.enware.com.au/warranty).

# product description

Enware Touch-Free Wall Sensor Tap is a sensor operated, hands-free tap that is installed onto walls above sinks, basins or wash troughs. It operates by sensing a hand in front of the sensor unit. Once the sensor is activated, the valve will remain open and water will flow until the hand is again placed in front of the sensor, closing the solenoid valve. It is not necessary for the hand to remain in the beam for the unit to keep the valve open.

If the solenoid valve remains open for more than 45 seconds, the unit will time-out and close the valve automatically. This is intended to conserve water and prevent overflows.

## COMPONENTS

The wall sensor tap kit comes standard with a fixed spout, a 1/2" solenoid valve, a sensor panel, a sensor bracket, and a 24 volt DC transformer.

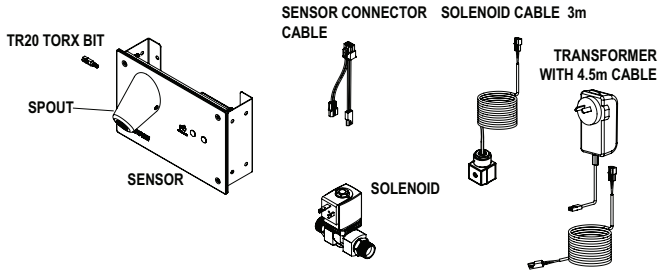

## dimensions

### SENSOR & SPOUT

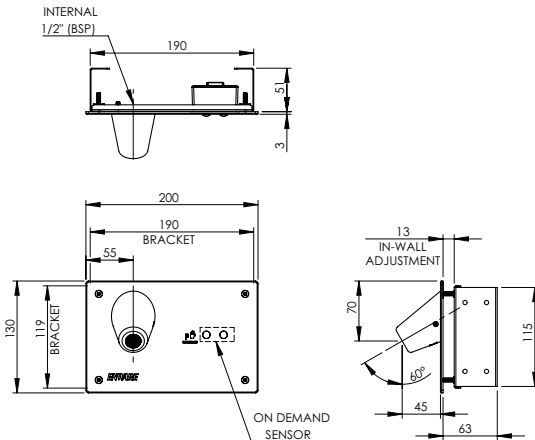

### SOLENOID

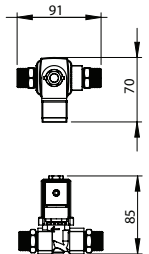

### TRANSFORMER

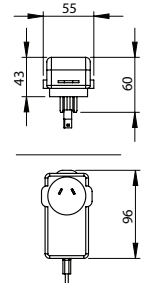

# before installation

## LOCATION OF SENSOR

When selecting a location to install the wall-mounted sensor, consider the following:

### Obstructions

Ensure that nothing is within range of the sensor. Any obstruction directly in front of, and within possible range of, the sensor can trigger the sensor randomly or constantly turn it on.

### Passing Traffic

Be sure that passing traffic cannot trigger the sensor. Allow at least 400mm clearance between sensor and passing traffic.

### Reflections and Lighting

If the sensor unit is installed into a location where a nearby wall or object is reflecting the Infrared light back, the unit is effectively blinded and will not operate. Up to 1.5 metre clearance may be necessary from reflective surfaces, such as ceramic tiles and stainless steel, directly in front of, and parallel to, the front face of the sensor. Any bright lighting reflecting off a highly reflective surface such as a stainless steel sink, or a high visibility reflective vest, may also interfere with correct sensor operation.

Do not install sensor directly in front of a mirror.

## SET-OUT HEIGHT

Suggested heights from finished floor:

Spout outlet	1050mm
	1120mm to point of water discharge (Australasian Health Facility Guidelines-2017)
Top of basin	850mm
	865mm (Australasian Health Facility Guidelines-2017)
	800 - 830mm (Reference: AS1428.1-2021)

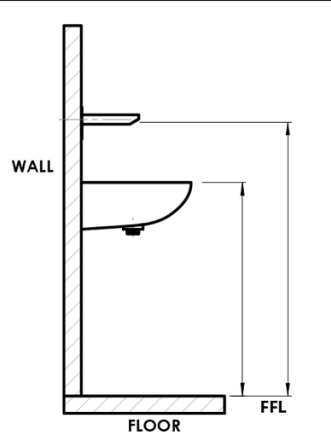

The diagram illustrates the installation of a wall-mounted sensor. It shows a vertical wall on the left and a horizontal floor at the bottom. The sensor is mounted on the wall. A horizontal line indicates the height from the finished floor level (FFL) to the top of the sensor. A vertical line indicates the height from the FFL to the point of water discharge from the spout outlet. The diagram also shows the top of the basin and the floor level.

## SET-OUT HEIGHT - FLOW PATTERN

Also take into consideration the water flow projection from spout outlet.

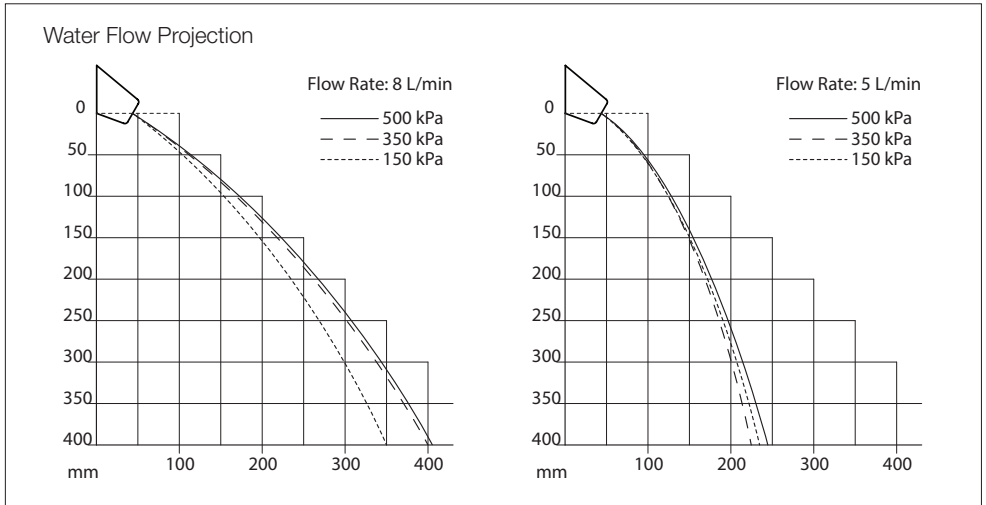

### ACCESS TO SENSOR TAP COMPONENTS

Ensure that access to the sensor, solenoid valve, transformer/ 240 V power point, and cabling is available for future maintenance when planning or installing assemblies.

- The solenoid valve and power point/ transformer is generally located either in the wall or in the ceiling space but they must be easily accessible for servicing purposes. This may be through an access panel on the wall or the ceiling.
- The cable should be located inside the wall cavity to connect to the power pack lead. All wiring, cables, or leads must be installed in such a way that they can be easily removed and replaced if necessary. It is recommended that all cabling is fed through 20mm conduit to allow for servicing and replacement in future.



**WARNING: Do not cut the wires or extend the existing cables, as this will void warranty. Use correct lead extension from Enware.**

### BEFORE CONNECTING WATER SUPPLY

- Ensure all supply lines are flushed thoroughly to remove debris prior to the installation of this product. Strainers (40 mesh) are recommended if debris is an ongoing problem.
- A pressure reduction valve may be required to comply with the recommended maximum supply pressure and/or balanced pressure requirements.
- Isolation valve and mesh strainer should be fitted before the solenoid, for ease of servicing and trouble-free solenoid operation.

### WATER SUPPLY TEMPERATURE

- As the sensor controls a single solenoid valve it is necessary that water temperature and flow are pre-set to the unit. It is recommended that an Aquablend Thermostatic Mixing Valve be used to provide pre-mixed water to the valve.

# installation - IN-WALL

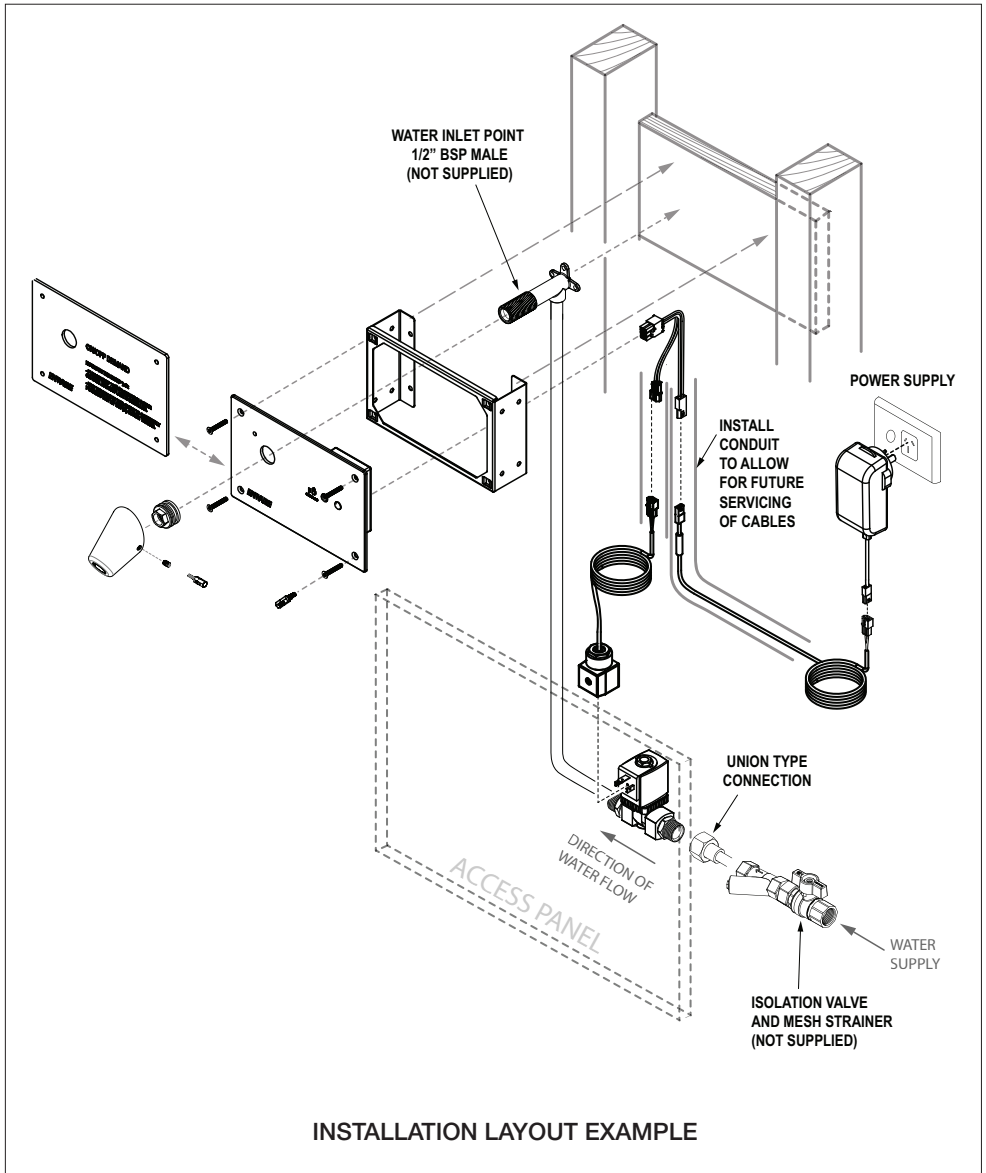

IMAGE 01

## SENSOR BRACKET INSTALLATION

Once the position of the spout and sensor plate is determined, fix the sensor mounting bracket inside wall.

Take note of the maximum and minimum depths for the sensor. Minimum wall depth 51mm is required for sensor bracket (including sensor and cables). Maximum wall depth is 63mm from finished wall to the back of sensor bracket. **SEE IMAGE 02 & 03**

## WATER SUPPLY, SOLENOID & OUTLET INSTALLATION

Water outlet point will be required within the bracket for the spout.

Prepare a 1/2" BSP male thread for water outlet point for the spout, allowing for 14mm of thread to protrude from finished wall. (11mm from the front plate/ protective cover.)

Ensure the water outlet point is fixed securely to a nogging or stable backing within the wall cavity.

Attach the plastic protective cover onto the bracket using the four fixing screws for sensor plate. Use the cover as a guide to determine the position of the water outlet point. **SEE IMAGE 04**

## INSTALLING THE SOLENOID

The solenoid valve is installed into the water supply line before the outlet spout. Quick-connect fittings or unions should be fitted on either end of the solenoid, with an isolation valve and a mesh strainer fitted before the solenoid, for ease of servicing and trouble-free solenoid operation. **SEE IMAGE 01**

Connect supply line to the inlet side of the solenoid, and outlet line to the outlet side of the solenoid. Semi-flexible connectors and braided hoses should not be used inside the wall.

Note: Ensure the solenoid is installed in the correct direction. The arrow on the solenoid body must align with the direction of water flow. **SEE IMAGE 05**

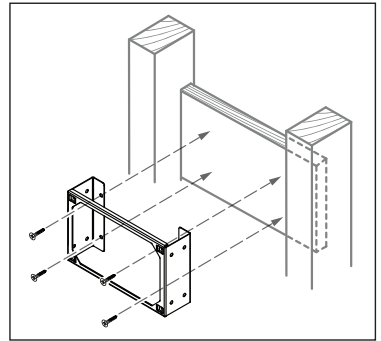

IMAGE 02

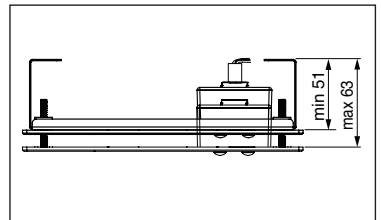

IMAGE 03

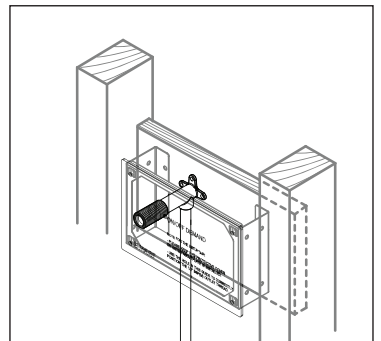

IMAGE 04



IMAGE 05

## TRANSFORMER AND CABLES

It is recommended that all cabling is fed through 20mm conduit to make servicing and replacement easier. The solenoid valve and power point/ transformer are generally located either in the wall space or in the ceiling but must be easily accessible for servicing. This may be through an access panel on the wall or the ceiling.

The transformer has a 4.5 metre lead to the sensor and the solenoid cable has a 3 metre lead from the sensor to the solenoid. Additional lead lengths up to 15 metres can be accommodated with extension cables (available separately from Enware).

### Wiring Method - SEE IMAGE 06

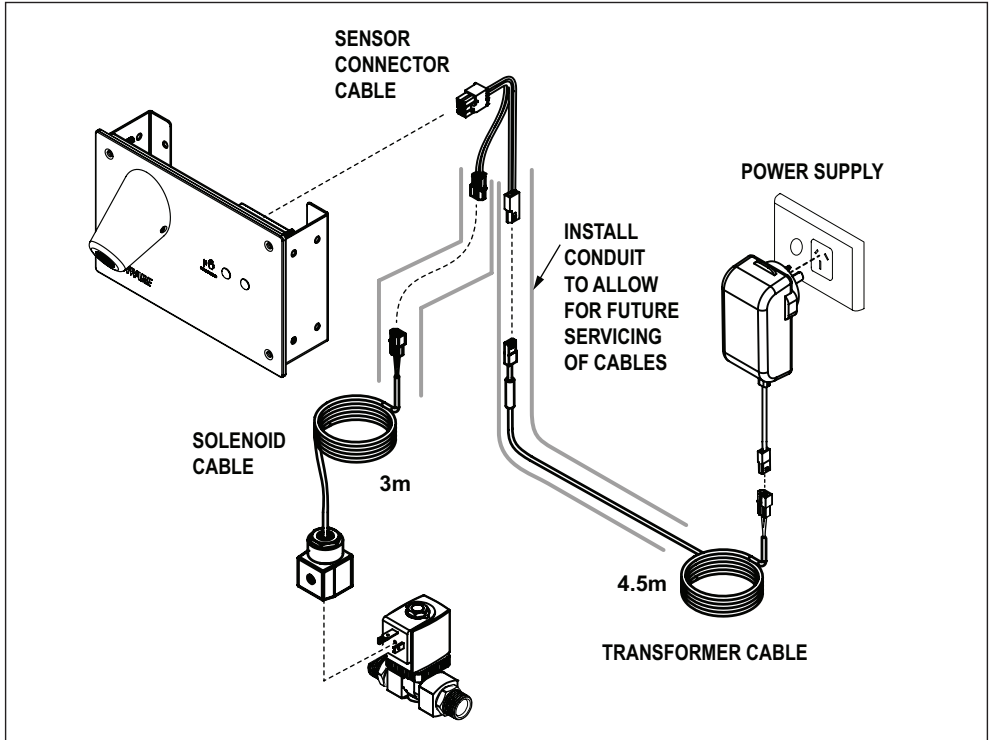

IMAGE 06

Plug the 24V DC transformer into the 240V AC power point.

**WARNING: Do not cut the electrical cable of the sensor tap, or alter the product in any way to suit installation.** Damage caused in this way will void warranty. Cable extensions are available if extra cable length is required. (Refer to Spare Parts Section)

Connect Transformer Cable to Sensor Connector Cable.

Connect Solenoid Cable to Sensor Connector Cable

Connect solenoid cable plug to the terminals on solenoid.  
(Note: Earth terminal on top is not used.)

When connecting cable plug to the solenoid, note that the black casing for solenoid can be turned around to suit the direction of wiring connection, by first loosening the hex nut on top. **SEE IMAGE 07**

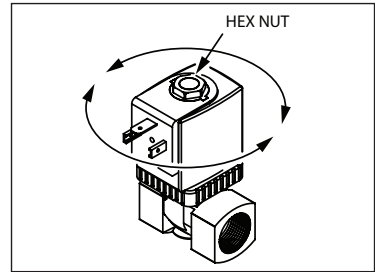

IMAGE 07

### **WARNING: Protecting from Water Spray**

Note that the transformers and connections are NOT spray or water proof. If there is a possibility of water coming into contact with any of the electrical components or connections (e.g. if electrical components are exposed underneath a basin), the unit and all of the interconnections should be installed into a water-proof enclosure.

### **TESTING**

Turn the water on and check for leaks. Connect all electrical components together temporarily, and test the tap.

Once correct operation of the tap is confirmed, disconnect and remove the sensor plate, and turn off the power to the transformer.

Keep the plastic protective cover on wall bracket for protection.

The tap is now ready for sheeting or finishing of the wall.

### **WALL CUT OUT DIMENSIONS**

Before the wall is sheeted or finished, allow for a cut out in the finished wall surface.

Wall cut out size: 193mm wide x 120mm high rectangular hole, and at least 51mm deep to allow for the bracket.

Sensor cable to come through the top, bottom, or back of sensor inside wall. **SEE IMAGE 08**

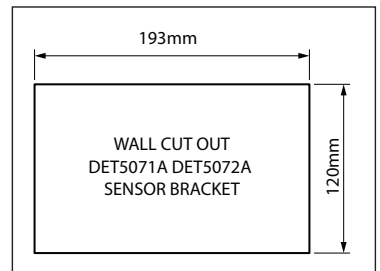

IMAGE 08

# installation - FRONT-OF-WALL

## MOUNTING THE SENSOR PLATE

After the wall is finished, remove four screws and remove protective cover.

Connect the sensor plate to connector cable in wall by joining the line plug and socket, observing the polarity of the plug.



### IMPORTANT:

Before fixing the sensor plate to wall, apply a thin bead of silicone sealant behind the plate along the top and side edges. Ensure that the plate is thoroughly sealed to the wall and that no water can get in behind the plate.

Any water entering behind the sensor plate will cause damage to sensor components and void warranty. **SEE IMAGE 09**

Take the four screws for sensor panel, and apply anti-seize lubricant to the thread of each screw.

Fit the sensor panel onto wall and fix it in place using the four screws. **SEE IMAGE 10**

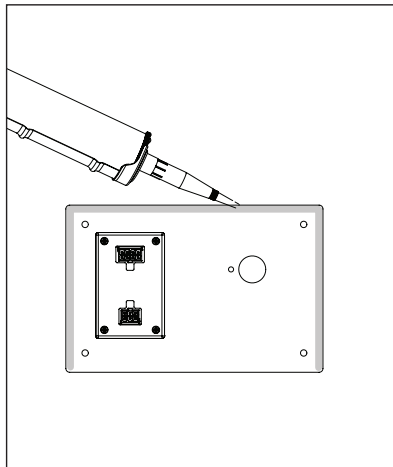

IMAGE 09

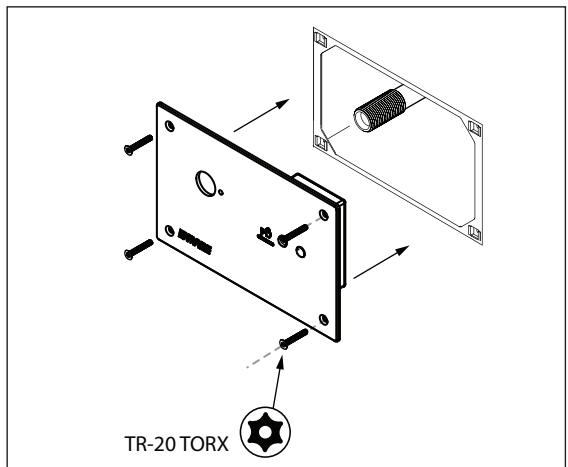

IMAGE 10

## INSTALLING THE SPOUT

Dismantle Wall Base from chrome spout. To do this, take out Grub Screw out from the side of spout using T10 Torx key supplied. Then, Loosely screw a 1/2" thread fitting onto the female thread of Wall Base located on the back of spout, and pull out the Wall Base from the spout assembly.

Apply thread sealant on 1/2" BSP male thread on wall. Screw Wall Base onto thread, all the way until the Wall Base is tight against the plate. Use a spanner on the hex of the Wall Base to tighten.

### SEE IMAGE 11

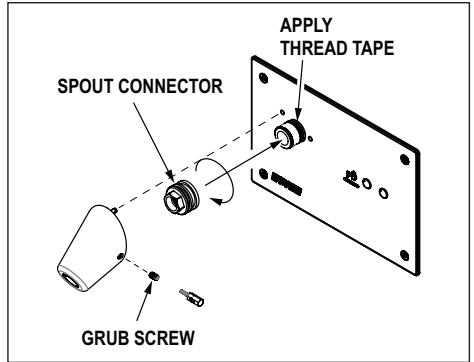

IMAGE 11

Fit spout over the Wall Base. If required, apply anti-pick silicone or silicone sealant of appropriate grade, around the edges on the contact surface of the spout.

Then, slowly but firmly push the spout all the way so that it is tight against the sensor plate. Make sure the anti-rotation pin locates correctly and that there are no gaps between the plate and the spout.

Secure the spout in position with the grub screw. Use T10 Torx key to tighten the grub screw with a small spanner. Do not overtighten.

**IMPORTANT:** Ensure the grub screw fits into the groove of the Wall Base, and is fitted all the way into the spout.

## TESTING

Turn on the power and water supply to the unit and test the operation.

See Operating Instructions overpage.

# operating instructions

## TO TURN ON

Place hand in front of sensor lens for half a second at a distance of 5 cm. Move hand away. Water starts to flow.

## TO TURN OFF

Place hand in front of sensor lens for half a second at a distance of 5 cm. Move hand away. Water flow stops.

If tap is not turned OFF, it will automatically turn OFF after 45 seconds\*.

When hand is within sensor range, sensor responds with a Red LED light in the sensor lens.

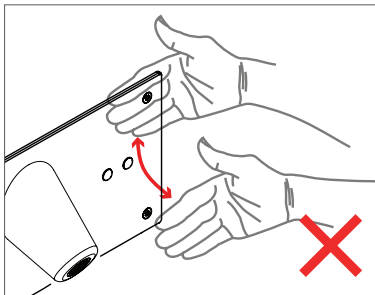
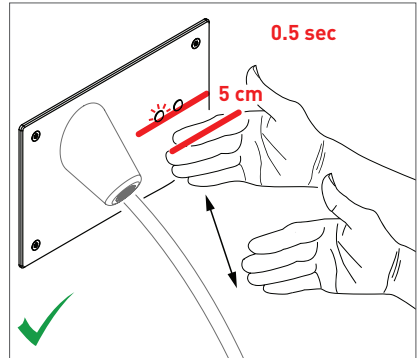

Wave quickly in front of sensor (does not activate)

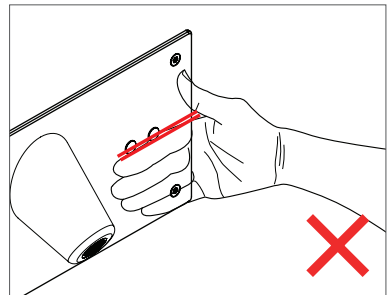

Hand too close to sensor (does not activate)

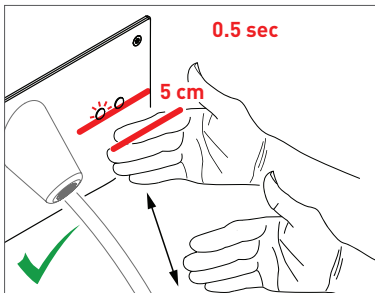

Place hand in front of sensor at 5cm for 0.5 sec

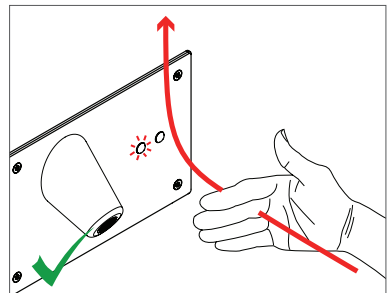









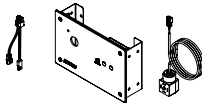
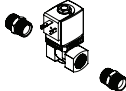

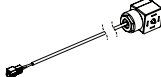

Move hand in towards sensor and pulling up

# troubleshooting

PROBLEM	CAUSE	RECTIFICATION
Tap/ water continues to flow  Tap does not turn off	Solenoid valve is installed the wrong way round	Re install valve correctly. Check the direction of water flow is with arrow. SEE IMAGE 05
	Debris in solenoid valve	Take solenoid apart and clean diaphragm. Refer to Solenoid Maintenance section.
	Solenoid diaphragm is damaged	Replace solenoid diaphragm or solenoid. Refer to Solenoid Maintenance section.
	Seat on solenoid body is damaged	Replace solenoid.
	An object is within sensor range	Remove object in sensor range.
Tap/ water does not turn on when hand is within sensor range  Red LED does not light up in the sensor lens	Power supply is off or transformer is damaged	Turn power on or replace transformer
	Sensor is damaged	Replace sensor
Tap/ water does not turn on when hand is within sensor range  Red LED lights up in the sensor lens	Water supply is off or Thermostatic Mixing Valve (TMV) has shut down	Check water supply and / or TMV.
	Solenoid cables connected incorrectly	Connect cables correctly. See IMAGE 06
	Solenoid valve is damaged	Replace solenoid valve
Tap/ water turns off slowly	Debris in solenoid valve	Take solenoid apart and clean diaphragm. Refer to Solenoid Maintenance section.
	Solenoid diaphragm is damaged	Replace solenoid diaphragm or solenoid. Refer to Solenoid Maintenance section.

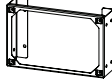
## spare parts

PART		ENWARE PRODUCT CODE
Sensor Kit – On/Off Demand (Sensor plate, sensor connector cable, bracket)		ENMS135A
Solenoid 1/2" – DC 24v (includes DC solenoid 1/2", 2x 1/2" nipples)		WMS8200S
Solenoid Service Kit - DC - (includes diaphragm, piston and spring to suit DC solenoid 1/2")		WMS8302
Transformer – DC 24v with 4.5m lead		EMDS802
Sensor Connector Cable 0.1m		673830
Solenoid Cable 3m with plug		673829
2m Extension Cable for Transformer or Solenoid		EMDS801
4.5m Extension Cable for Transformer or Solenoid		EMDS801-4.5
The Custodian® Basin Outlet - On Wall Mounted		CNBSN-FF
Aerator Insert 3/8" and O-ring for DET660B		DET667
Aerator Retainer Ring		DET668
Aerator Spanner Key for DET660B		DET669
T-10 Torx Post Driver Bit		671184
Metal Bracket for Sensor Plate		592085
Fixing Screw for Sensor Plate		672480
TR-20 Torx Fixing Screw Bit		672483

## service & maintenance

### CLEANING

Enware products should be cleaned with a soft damp cloth using only mild liquid detergent or soap and water. Do not use cleaning agents containing a corrosive acid, scouring agent or solvent chemicals. Do not use cream cleaners, as they are abrasive. Use of unsuitable cleaning agents may damage the surface. Any damage caused in this way will not be covered by warranty.

### ACCESS TO AERATOR & FLOW CONTROL

Spout aerator should be checked periodically for debris.

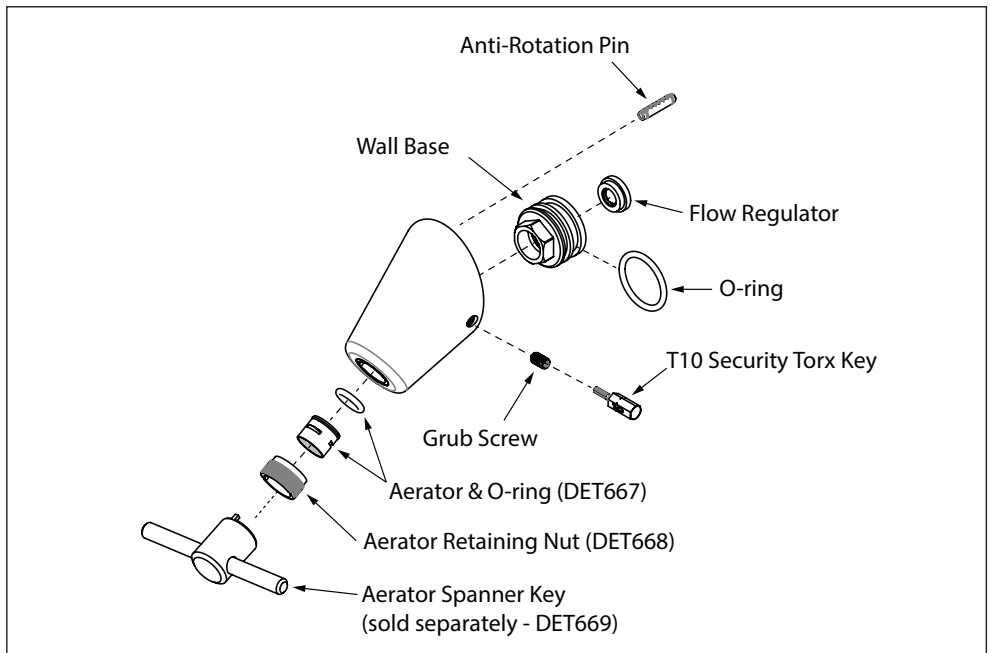

IMAGE 12

## SOLENOID MAINTENANCE

For long periods of non-use, a minimum activation of 1-2 times per day is recommended.

High frequency of use and high water supply pressures reduce the service life of a solenoid.

If the solenoid is not working correctly or is leaking, go through the following steps to service the solenoid. The most common cause of solenoid malfunction is debris getting caught inside, in which case the solenoid needs to be dismantled and cleaned. Service kits including replacement diaphragms are available.

### TO ACCESS THE SOLENOID VALVE

1. Turn water supply off and activate the sensor to drain water from the line. Turn power off to the sensor.
2. In most cases it is easier to remove the complete solenoid valve from the installation to service it. Remove the electrical connectors from the solenoid terminals, undo the water connections on both the water inlet and outlet of the solenoid, and remove the solenoid.
3. The solenoid can be disassembled and checked for debris or damage to the diaphragm. Refer to "Servicing the Solenoid" instructions below. Take note of the location of the components so that it can be reassembled later in the correct order.
4. Service or replace the solenoid and re-install into the line. Push the cable connectors back onto the solenoid terminals.
5. Turn power and water back on and test the tap.

### SERVICING THE SOLENOID

Tools required: Spanner, T20 Torx Bit or Slotted Screw Driver

1. Remove the hex nut located on top of the solenoid. **SEE IMAGE 10**
2. Remove the black coil body and plastic cover from the core tube by sliding up. **SEE IMAGE 11**
3. Using a T20 Torx screw driver (star bit) or a slotted screw driver, remove the 4 Torx screws that are holding the core tube. Use the correct size tool and take care not to round the screws heads. Keeping in mind that the plunger inside the core tube is spring loaded, dismantle the valve with care. Take note of the order of parts assembled. **SEE IMAGES 12,13**
4. Check seat and diaphragm for debris or any damage. **SEE IMAGE 14**

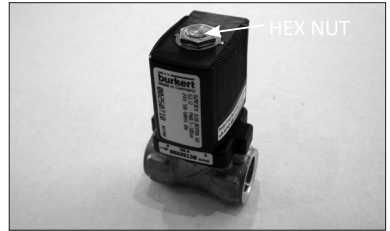

IMAGE 10

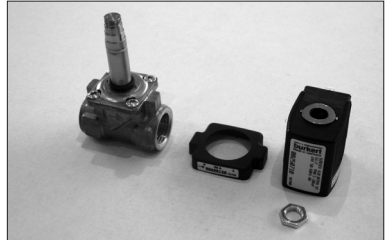

IMAGE 11

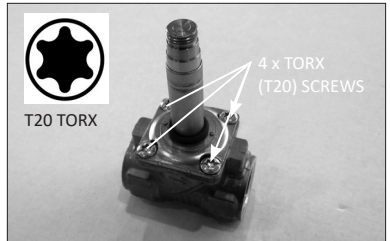

IMAGE 12

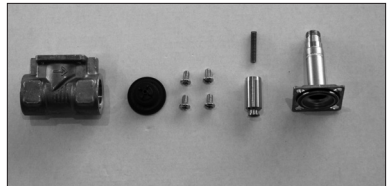

IMAGE 13

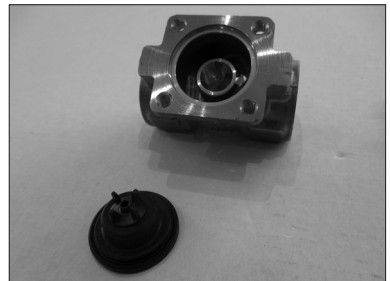

IMAGE 14

5. Note the small hole in the rubber diaphragm. It is important that this hole is clear and not obstructed by debris. Clean the diaphragm by rinsing with water.

**SEE IMAGE 15**

6. Replace any component that is damaged.  
(Service Kit code WMS8302)

7. To reassemble, firstly place the rubber diaphragm in correct position. The hole in the diaphragm should be assembled either at 2 O'clock or 4 O'clock position, when the direction of flow is going from left to right, as shown below. The arrow is indicated on the solenoid body. **SEE IMAGES 16-19**

Note: Do not apply grease to internal components of solenoid. Grease can deteriorate over time and cause the solenoid to malfunction.

8. Reassemble the plunger with spring into the core tube. Check that the spring is reassembled back together inside the core tube, and no foreign material is in the core tube to restrict the plunger movement.

9. Once this is done, place the core tube back on top of the valve and tighten back up with the 4 Torx screws.

10. Once the core tube is tightened, place the plastic cover which goes over the core tube. This covers the screws. When doing so, ensure the sticker on the plastic has the same flow direction as the body.

11. Finally place the black coil body back over the core tube, and tighten the hex nut back up.



**IMAGE 15**

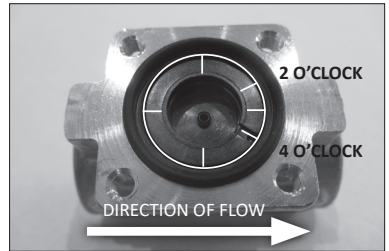

**IMAGE 16**

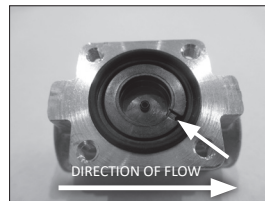

**IMAGE 17**

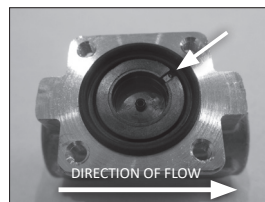

**IMAGE 18**

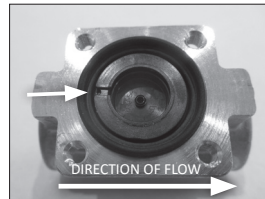

**IMAGE 19**



# product warranty statement - WATTS AUSTRALIA

EFFECTIVE FROM 20 November 2023

This Warranty Statement applies to products supplied by Australian Valve Group Pty Ltd (ACN 068 227 270) (**AVG**) or Enware Pty Ltd (ACN 662 302 767) (**Enware**) (each of AVG and Enware, a Supplier) and installed within Australia.

Subject to the terms and conditions outlined in this Warranty Statement, each Supplier warrants to its customers that a product supplied by it (**Product**) will be free from all defects in material and workmanship under normal usage for the applicable Warranty Period (as set out in the Warranty Table below). The Warranty Period commences from the date of delivery of the relevant Product.

## 1. Conditions

The warranty provided under this Warranty Statement will not apply in respect of a Product (or any Product defect, fault or resulting damage) if:

- (a) the Product is not installed and maintained in accordance with the requirements of the applicable laws, standards and codes (including, without limitation to, the National Construction Code Volume Three – Plumbing Code of Australia, associated reference standards as applicable at the time and AS/NZS 3500);
- (b) the Product is not installed and maintained by a qualified technician in accordance with the relevant installation and operation manual and instructions; and
- (c) any Product defect, faulty or resulting damage arises from:
  - (i) failure by you or any other person to follow the relevant manual or instructions (relating to the handling, storage, installation, fitting, connection, adjustment, maintenance or repair of the Product) published or provided by the Supplier;
  - (ii) failure by you or any other person responsible for the fitting, installation, or other work on the Product to follow or conform to applicable laws, standards and codes (including, without limitation to, the AS/NZ 3500 set of Standards, all applicable State and Territory Plumbing Codes, the Plumbing Code of Australia and directions and requirements of local and other statutory authorities);
  - (iii) any parts or components not manufactured by the Supplier (or otherwise not authorised by the Supplier) are installed or combined with the Product, without the prior authorisation of the Supplier; or
  - (iv) any act or circumstance beyond our control including, without limitation to, accident, abnormal use, vandalism, fouling caused by foreign material, damage from adverse water conditions, chemical, acts of God, damage to buildings, other structures and infrastructure and loss or damage during transit or transportation of the Product, or any abuse, misuse, misapplication, improper installation or connection, or improper maintenance or alteration of the Product.

## 2. Make a claim

To make a claim under this Warranty Statement, you must notify the relevant Supplier in writing within 7 days of any alleged defect in the Product coming to your attention and provide the Supplier with proof of your purchase of the Product to the relevant Supplier:

- (a) If the Product is supplied by **AVG**, please contact AVG by telephone at 1800 284 287, or by email via its online portal <https://www.wattsau.com.au/support>.
- (b) If the Product is supplied by **Enware**, please complete the Product Service Request form (ENF091), which is available on request from our office (see contact details below), or online via <https://www.enware.com.au/warranty-service-form/>. All notifications and accompanying forms must be sent to Enware marked for the attention of Enware, 9 Endeavour Road, Caringbah NSW 2229. Enware can also be contacted by telephone (1300 369 273) or by email ([info@enware.com.au](mailto:info@enware.com.au)).

On receipt of a notification from you of a claim under this Warranty Statement, the relevant Supplier may contact you requesting you provide reasonably additional evidence, information or details about your claim, or requiring that the relevant Product should be returned to the Supplier (in accordance with the Supplier's instructions) for inspection and testing.

Your failure to comply with any such request within a reasonable amount of time may result in your claim under this Warranty Statement being rejected.

## 3. Our responsibilities

(a) In the event that the Supplier is reasonably satisfied that there is a defect in the relevant Product within the applicable Warranty Period, the Supplier will, at its option, replace the Product, supply an equivalent product or repair the Product, free of charge. Your costs in making a warranty claim under this Warranty Statement, including any costs in relation to freight, collection, delivery and installation, are to be borne and paid by you. However, in respect of a Product, it is indicated in the Warranty Table that labour support will be provided, and the Supplier is reasonably satisfied that a defect in the Product takes place during the period that labour support will be provided as indicated in the Warranty Table, the Supplier will bear the costs for delivery, repair and installation of the replacement Product (as applicable).

(b) TO THE EXTENT PERMITTED BY LAW AND SUBJECT TO PARAGRAPH 4 BELOW AND THE OPERATION OF THE AUSTRALIAN CONSUMER LAW:

- (i) THE WARRANTY SET OUT IN THIS WARRANTY STATEMENT IS GIVEN EXPRESSLY AND IS THE ONLY WARRANTY GIVEN BY THE SUPPLIER WITH RESPECT TO THE RELEVANT PRODUCT;
- (ii) THE SUPPLIER MAKES NO OTHER WARRANTIES, EXPRESS OR IMPLIED;
- (iii) THE SUPPLIER HEREBY SPECIFICALLY DISCLAIMS ALL OTHER WARRANTIES, EXPRESS OR IMPLIED, INCLUDING BUT NOT LIMITED TO, THE IMPLIED WARRANTIES OF MERCHANTABILITY AND FITNESS FOR A PARTICULAR PURPOSE; AND
- (iv) THE REMEDY DESCRIBED IN THIS WARRANTY STATEMENT SHALL CONSTITUTE THE SOLE AND EXCLUSIVE REMEDY FOR BREACH OF WARRANTY, AND THE SUPPLIER SHALL NOT BE RESPONSIBLE FOR ANY INCIDENTAL, SPECIAL OR CONSEQUENTIAL DAMAGES, OR LOST PROFITS OR THE COST OF REPAIRING OR REPLACING OTHER PROPERTY WHICH IS DAMAGED IF THE PRODUCT DOES NOT WORK PROPERLY.

## 4. Australian Consumer Law

This paragraph 4 applies if you are a 'Consumer' (as defined in section 3 of the Australian Consumer Law (**ACL**)) and the Product or services supplied to you falls within the goods or services which, for the purposes of the ACL, are of a kind ordinarily acquired for personal, domestic or household use or consumption.

The Products and services provided by the Supplier come with guarantees that cannot be excluded under the ACL, and noting in this Warranty Statement should be interpreted as attempting to exclude, restrict or modify such guarantees or your rights under the ACL. For major failures with any services, you are entitled:

- (c) to cancel your service contract with us; and
- (d) to a refund for the unused portion, or to compensation for its reduced value.

You are also entitled to choose a refund or replacement for major failures with Products. If a failure with the Product or a service does not amount to a major failure, you are entitled to have the failure rectified in a reasonable time. If this is not done you are entitled to a refund for the Products and to cancel the contract for the service and obtain a refund of any unused portion. You are also entitled to be compensated for any other reasonably foreseeable loss or damage from a failure in the Products or service\*.

## 5. Warranty table

\*the applicable period commences on the date of delivery of the Product.

PRODUCT GROUP	PRODUCT SERIES CODES	WARRANTY PERIOD (YEARS)*	LABOUR SUPPORT (YEARS)
Enware Electronic-Sensor	DET50	3	2



1300 369 273  
info@enware.com.au  
enware.com.au