

Earth Lug - 50mm X 100mm, 2 Drill Holes for Attachment

Earthing tab SS316 for mounting on foot base of ECE shower or pedestal eyewash

KEY FEATURES

- Strong and durable corrosionresistant construction - SS316
- 50mm × 100mm lug, bent at 150°
- Two drilled mounting holes for secure attachment



PRODUCT CODE

EAA975F

Earth Lug - 50mm X 100mm, 2 Drill Holes for Attachment

TECHNICAL DATA

Finish	Stainless Steel
--------	-----------------

COMPATIBLE PRODUCTS

ECE060	Emergency Stainless Steel Combination Shower with Hand Operated Eye Wash
ECE090	Emergency Stainless Steel Combination Shower Hand/Foot Operated Eye Wash
ECE240	Emergency Stainless Steel Combination Shower with Hand Operated Eye/Face Wash
ECE270	Emergency Stainless Steel Combination Shower with Hand/Foot Operated Eye/Face Wash

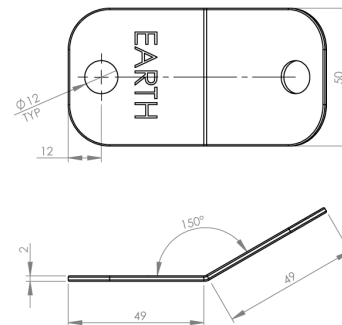

Due to ongoing Research and Development, specifications may change without notice.
Component specifications may change on some export models.
Refer to warranty statement for warranty details - www.enware.com.au/warranty.