

HYDRUS2 COLD DN200 L520mm M-BUS

The HYDRUS2 M Bus ultrasonic water meter provides accurate, maintenance free measurement with integrated wired M Bus communication for BMS integration.

Its advanced ultrasonic technology provides long term stability, no moving parts, and reliable performance even in demanding conditions. The meter supports high resolution data, leak detection, backflow alerts, and robust diagnostics to enhance system visibility.

With IP68 protection it is suitable for both indoor and outdoor use, with its long battery life it will continue to function in a blackout, a wide dynamic range of up to R800 enables measurement of flow down to the level of drips, support for both horizontal and vertical installation and no need for calming sections. HYDRUS2 suits a broad range of commercial and industrial environments.

The HYDRUS2 wired M Bus offers dependable data delivery, advanced BMS integration for facilities needing detailed, automated water reporting.

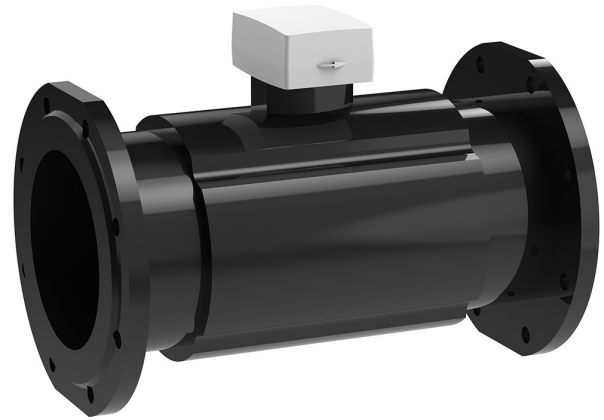

PRODUCT CODE

EHM50200X5FM HYDRUS2 COLD DN200 L520mm M-BUS

KEY FEATURES

- WaterMark certified on all sizes
- NMI approved on all sizes
- Higher performance than class 2 requirements
- Q1/Q3 (Dynamic range) up to R800
- Ultrasonic design minimises sedimentation
- Long-term stability under difficult conditions
- Horizontal and vertical installation
- IP68 permanent immersion (suitable for outdoor installation)
- U0 / D0, no need for calming sections
- No moving parts & no magnetic influence
- No measurement of air
- Integrated communications
- Battery lifetime up to 16 years
- Display with error and alarm codes including leakage detection
- Available in T50 (Cold Water) DN 20, 25, 32, 40, 50, 80, 100, 150, 200
- Available in T90 (Hot Water) DN 15, 20, 25, 32, 40



HYDRUS2 COLD DN200 L520mm M-BUS

TECHNICAL DATA

Check Valve	None
Couplings	None included
Strainer	No
Display Indication	LCD, 9-digit, additional symbols / display counter / unit
Values Displayed	Current Total Volume, Current Flow Rate, Remaining Battery Life, Error and Alarms, Software Version, Display Test
Maximum Temperature Safety	50°C
Minimum Medium Temperature Range	1°C
Dynamic Range (Q1/Q3) Horizontal	800
Dynamic Range (Q1/Q3) Vertical	250
Minimum Flow Rate Q1	500L/hr
Transitional Flow Rate Q2	800L/hr
Permanent Flow Rate Q3	400000L/hr
Overload Flow Rate Q4	500000L/hr
Accuracy Class	2
Inlet Connection	Round Flange 200mm
Outlet Connection	Round Flange 200mm
Battery Lifetime	Up to 16 years
Protection Class	IP68
Nominal Diameter	200
Interfaces	WM-BUS OMS Radio (R3, R4), Wired PULSE
Radio	No
Sending Interval	R3: 14s, R4: 15m
Wired Pulse	No
Wired M-BUS	Yes
Technical Notes	
WM40207 AS3565.1 Lead Free (WaterMark)	
NMI R49-1	

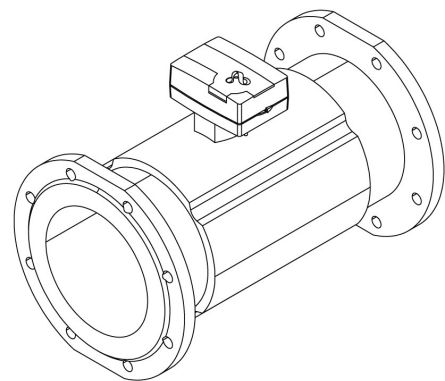
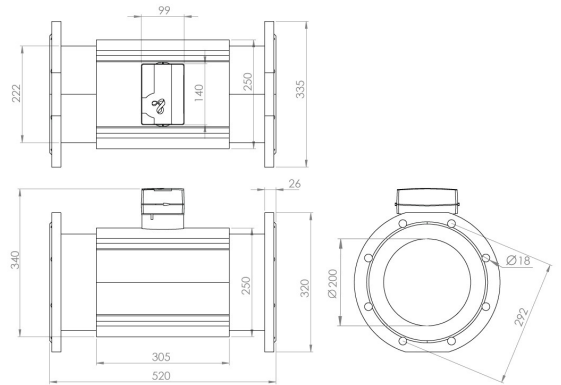

Pressure Loss Graph

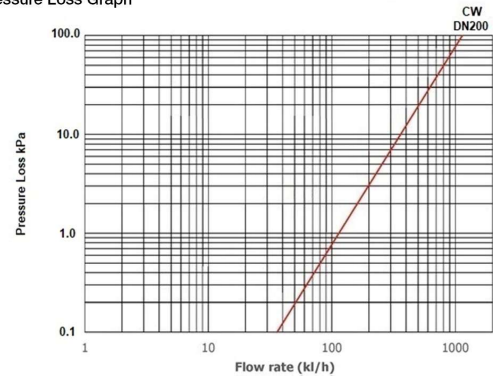

Typical Error Graph

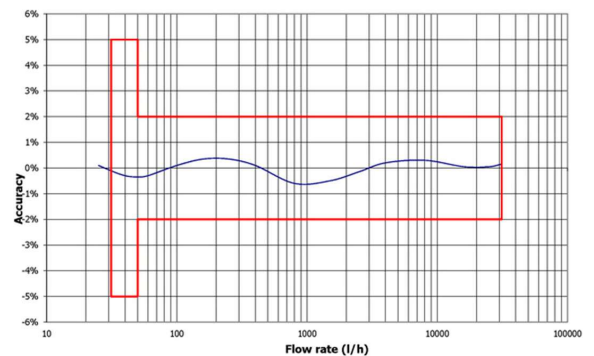

Due to ongoing Research and Development, specifications may change without notice.
Component specifications may change on some export models.
Refer to warranty statement for warranty details - www.enware.com.au/warranty.