

Enware In-Wall Cistern - Slim Style

Installation and Maintenance Instructions

EIWC-W480



technical data

Working Pressure Range	Min 50 kPa Max 500 kPa
Inlet Connection	1/2" BSP (DN15)

Enware products are to be installed in accordance with the Plumbing Code of Australia (PCA) and AS/NZS3500. Installations not complying with PCA and AS/NZS 3500 may void the product and performance warranty provisions.

Reference should also be made to the Australasian Health Facility Guidelines (AHFG), ABCB and Local Government regulations when considering the choice of, and the installation of these products.

This product must be installed and commissioned by a qualified plumber.

For use with potable water only.

NOTE: Enware Australia advises:

1. Due to ongoing Research and Development, specifications may change without notice.
2. Component specifications may change on some export models.

I00329_21 Dec 2023

1300 369 273 | info@enware.com.au | enware.com.au

ENWARE
A WATTS Brand

dimensions

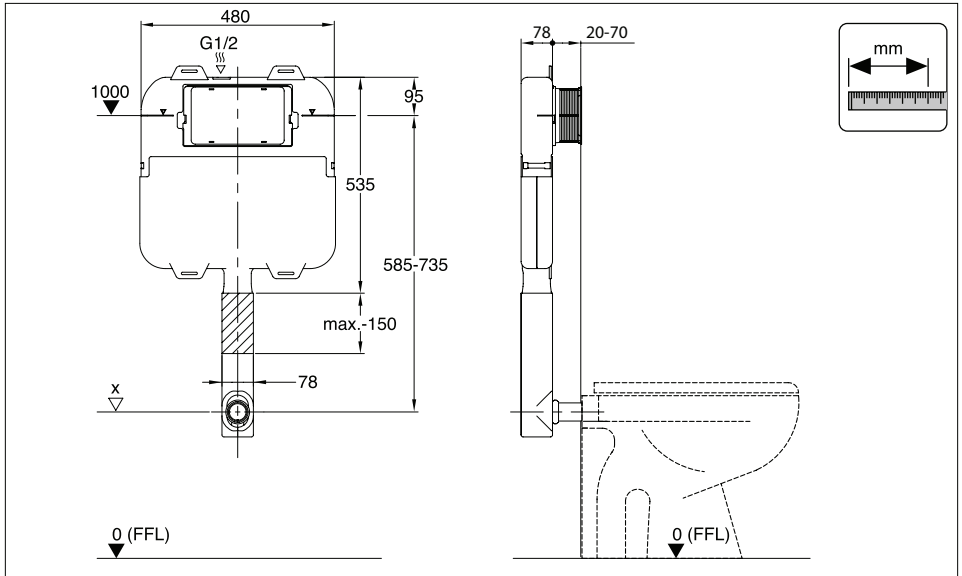

All measurements are in millimetres.

Drawing not to scale.

Refer to pan specifications for dimensions from finished floor level (FFL) to pan inlet and outlet.

installation

- All supply lines must be flushed thoroughly to remove debris prior to the installation of this product, as per AS/NZS 3500.1. Strainers (40 mesh) are recommended if debris is an ongoing problem.
- A pressure reduction valve may be required to comply with the recommended maximum supply pressure and/or balanced pressure requirements.

IN-WALL CISTERN INSTALLATION

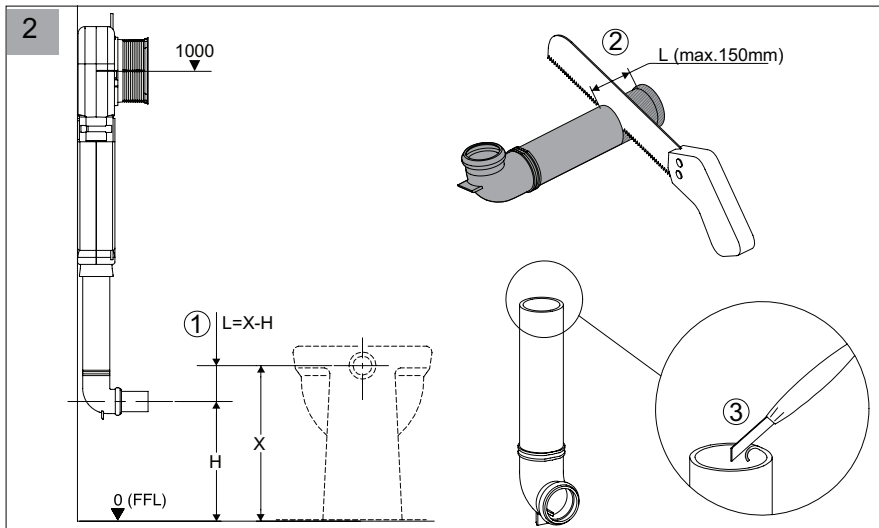
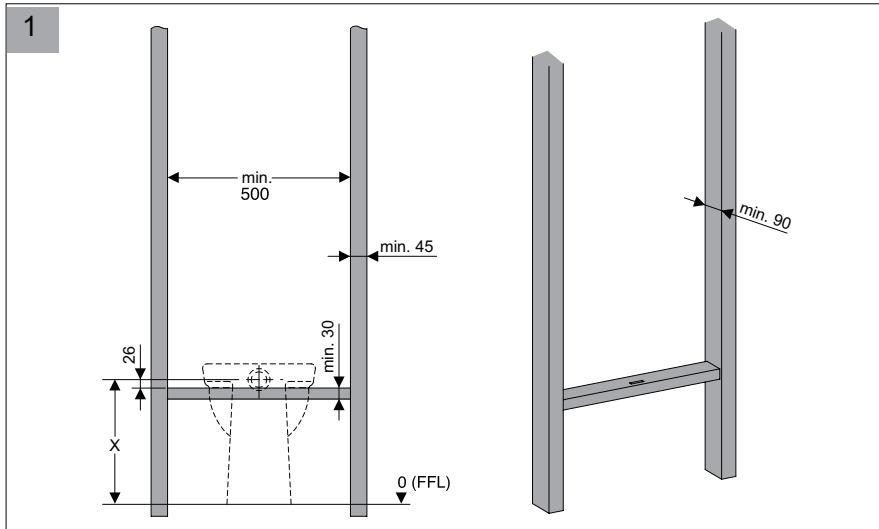

3

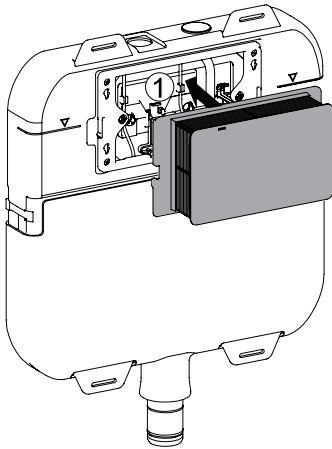

"Click"

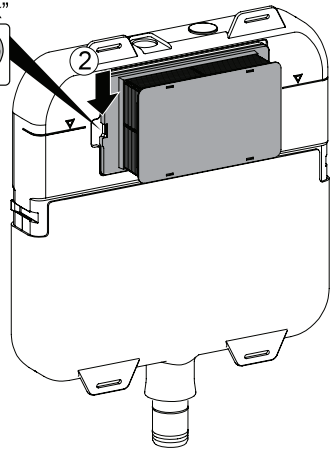

4

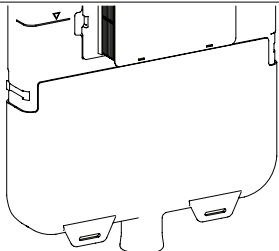

2

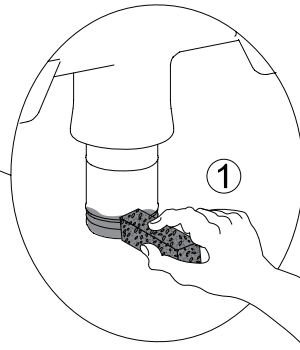

Use lubricant block supplied to lubricate fitting, as shown.

5

①

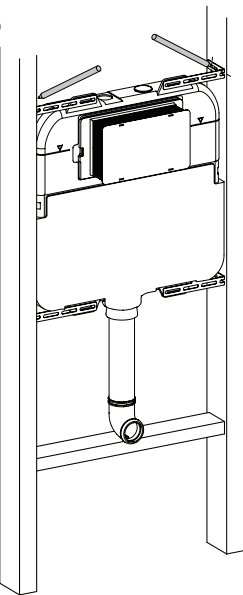

②

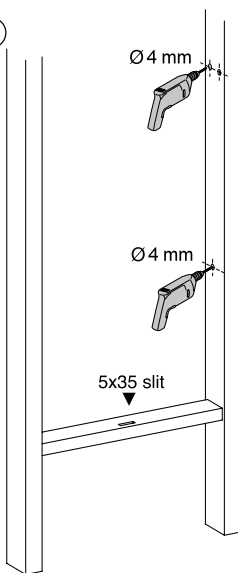

The tab at base of flush pipe should slot into a 5x35mm slit in the nogging.

6

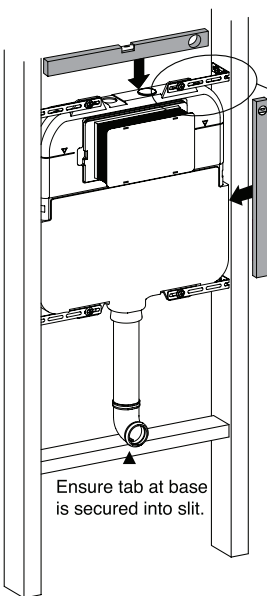

Ensure tab at base is secured into slit.

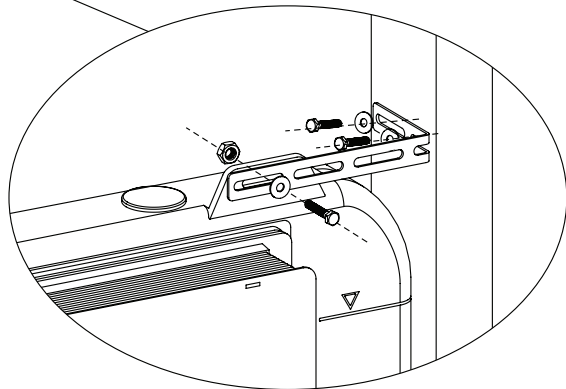

7

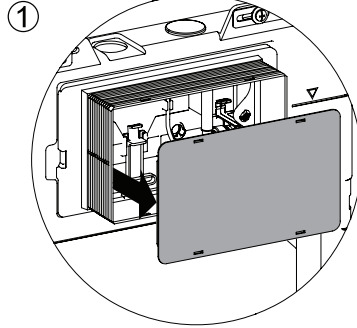
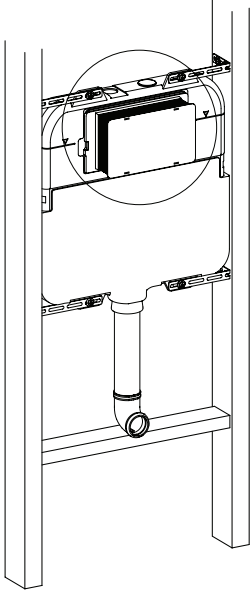

Remove plate and follow Steps 8 and 9 to fit inlet valve fittings.

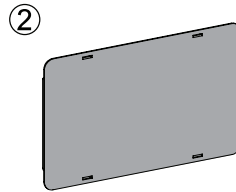

8

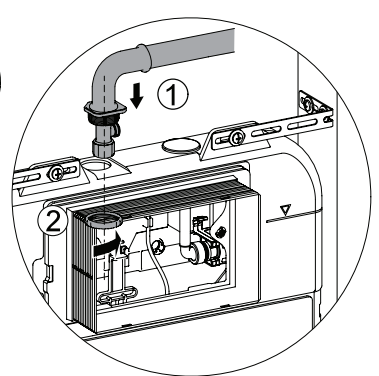
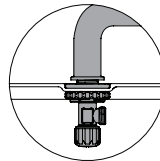
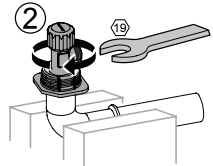
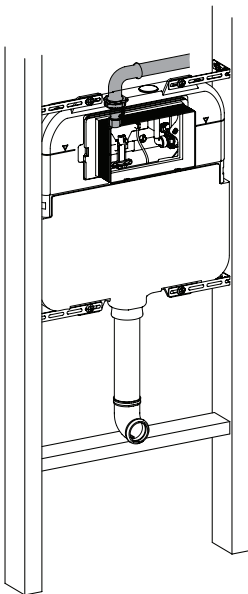

9

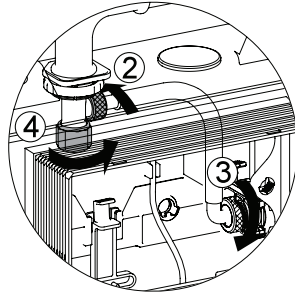
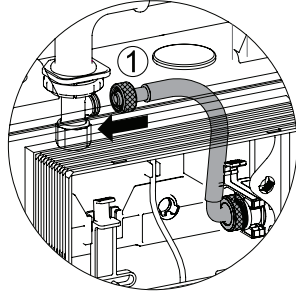
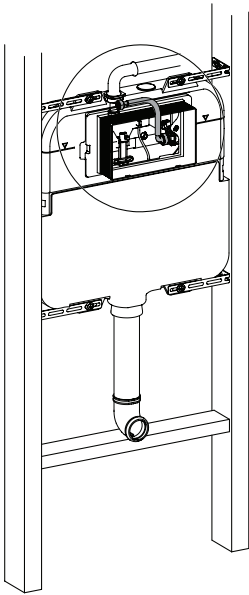

10

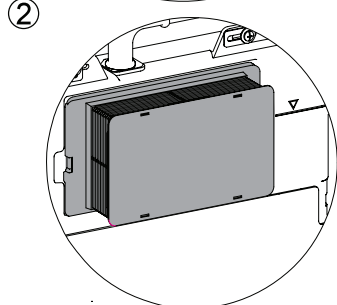
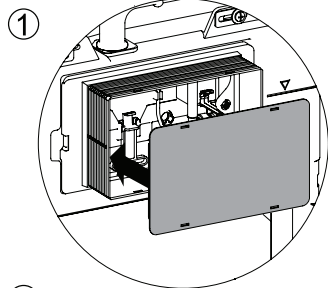
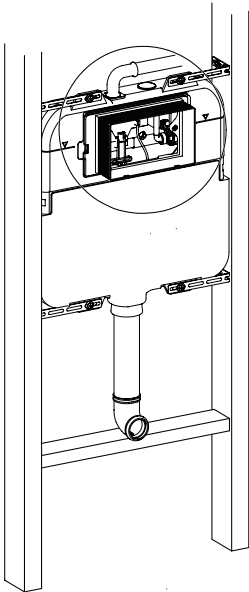

11

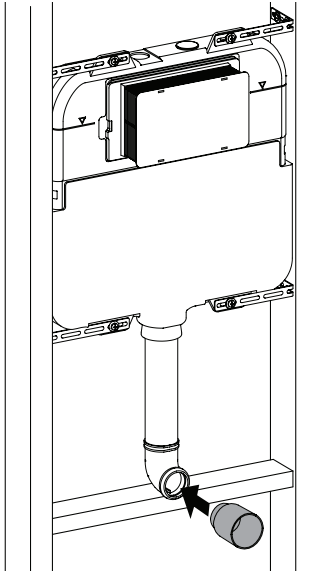

12

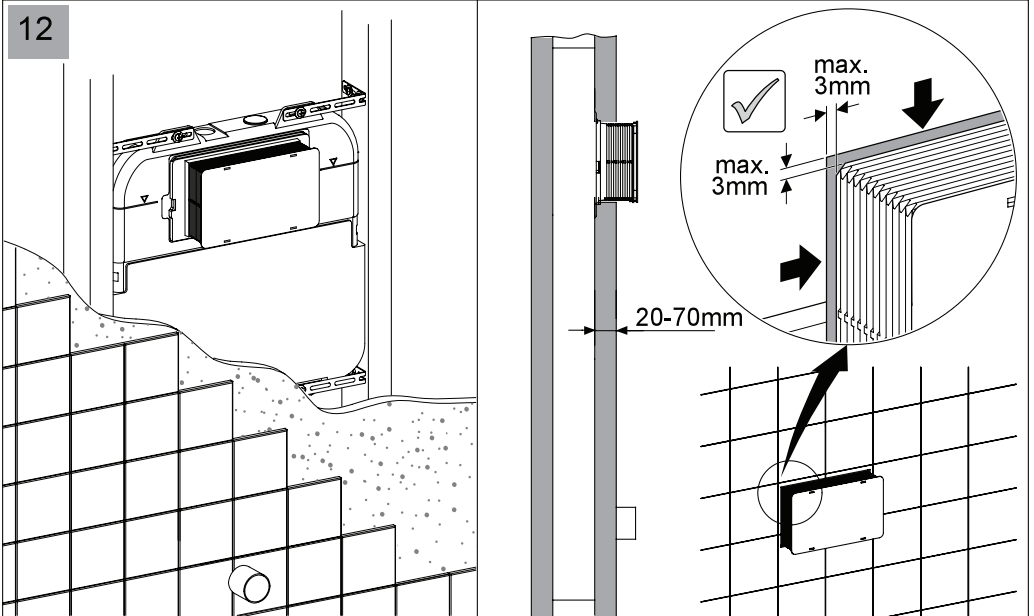

PAN INSTALLATION

Note: Refer to pan installation instructions.

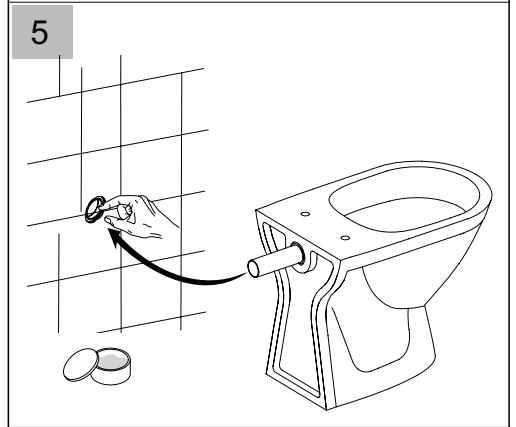
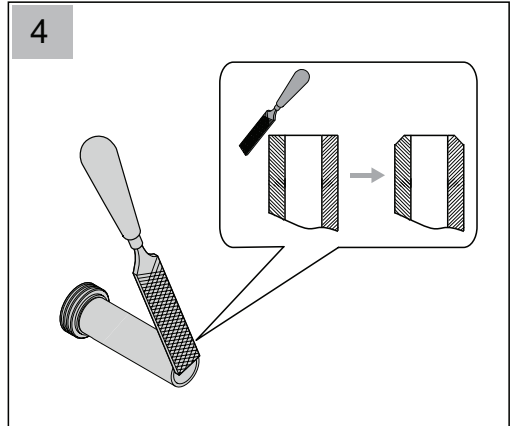
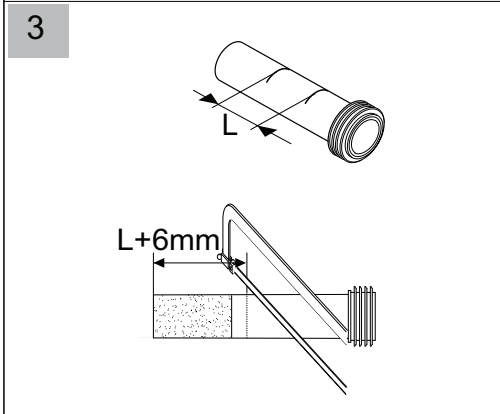
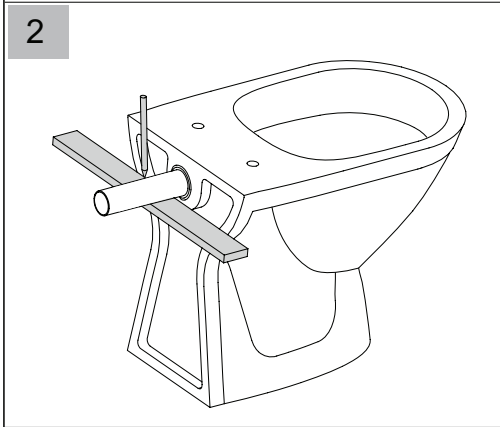
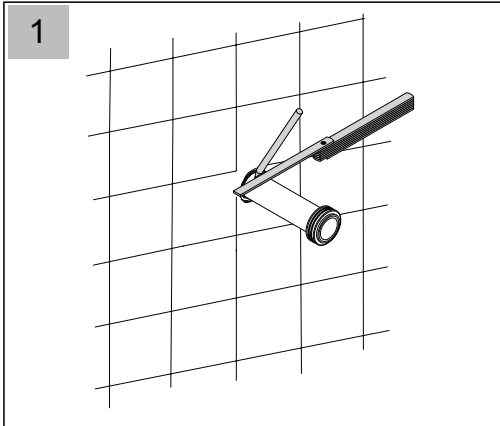

maintenance

Turn off water supply before carrying out any repair or maintenance work on flush valves.

To change outlet valve seal washer, remove the outlet valve from cistern, and pull off the outlet valve washer located at the bottom of the valve. Replace with a new washer.

Refer to Troubleshooting section for any problems with the toilet.

CLEANING

Enware products should be cleaned with a soft damp cloth using only mild liquid detergent or soap and water. Do not use cleaning agents containing a corrosive acid, scouring agent or solvent chemicals. Do not use cream cleaners, as they are abrasive. Use of unsuitable cleaning agents may damage the surface. Any damage caused in this way will not be covered by warranty.

troubleshooting

PROBLEM	CAUSE	RECTIFICATION
Toilet not flushing away Drain blockages	Flush volume too low	Increase flush volume
Water constantly runs into bowl	Cistern fill level is too high	Adjust fill level on inlet valve
	Inlet valve failure	Replace inlet valve assembly
	Inlet valve is fouled by debris	Dismantle inlet valve and clean inlet valve seal
	Outlet valve seal washer is worn or damaged	Replace outlet valve seal washer
	Outlet valve is fouled by debris	Check outlet valve for any debris and clean

spare parts

EIWC-S001	Inlet Valve Assembly	 A white, vertical inlet valve assembly with a black handle and a clear plastic cap at the bottom.
EIWC-S002	Outlet Valve Assembly	 A white, vertical outlet valve assembly with blue and red hoses attached to the top.
EIWC-S003	Pneumatic Hose 4mm OD x 400mm - Pair	

product warranty statement - WATTS AUSTRALIA

Effective 27 October 2023

This Warranty Statement applies to products supplied by Australian Valve Group Pty Ltd (ACN 068 227 270) (**AVG**) or Enware Pty Ltd (ACN 662 302 767) (**Enware**) (each of AVG and Enware, a Supplier) and installed within Australia.

Subject to the terms and conditions outlined in this Warranty Statement, each Supplier warrants to its customers that a product supplied by it (**Product**) will be free from all defects in material and workmanship under normal usage for the applicable Warranty Period (as set out in the Warranty Table below). The Warranty Period commences from the date of delivery of the relevant Product.

1. Conditions

The warranty provided under this Warranty Statement will not apply in respect of a Product (or any Product defect, fault or resulting damage) if:

- (a) the Product is not installed and maintained in accordance with the requirements of the applicable laws, standards and codes (including, without limitation to, the National Construction Code Volume Three – Plumbing Code of Australia, associated reference standards as applicable at the time and AS/NZS 3500);
- (b) the Product is not installed and maintained by a qualified technician in accordance with the relevant installation and operation manual and instructions; and
- (c) any Product defect, faulty or resulting damage arises from:
 - (i) failure by you or any other person to follow the relevant manual or instructions (relating to the handling, storage, installation, fitting, connection, adjustment, maintenance or repair of the Product) published or provided by the Supplier;
 - (ii) failure by you or any other person responsible for the fitting, installation, or other work on the Product to follow or conform to applicable laws, standards and codes (including, without limitation to, the AS/NZ 3500 set of Standards, all applicable State and Territory Plumbing Codes, the Plumbing Code of Australia and directions and requirements of local and other statutory authorities);
 - (iii) any parts or components not manufactured by the Supplier (or otherwise not authorised by the Supplier) are installed or combined with the Product, without the prior authorisation of the Supplier; or
 - (iv) any act or circumstance beyond our control including, without limitation to, accident, abnormal use, vandalism, fouling caused by foreign material, damage from adverse water conditions, chemical, acts of God, damage to buildings, other structures and infrastructure and loss or damage during transit or transportation of the Product, or any abuse, misuse, misapplication, improper installation or connection, or improper maintenance or alteration of the Product.

2. Make a claim

To make a claim under this Warranty Statement, you must notify the relevant Supplier in writing within 7 days of any alleged defect in the Product coming to your attention and provide the Supplier with proof of your purchase of the Product to the relevant Supplier:

- (a) If the Product is supplied by **AVG**, please contact AVG by telephone at 1800 284 287, or by email via its online portal <https://www.wattsau.com.au/support>.
- (b) If the Product is supplied by **Enware**, please complete the Product Service Request form (ENF091), which is available on request from our office (see contact details below), or online via <https://www.enware.com.au/warranty-service-form/>. All notifications and accompanying forms must be sent to Enware marked for the attention of Enware, 9 Endeavour Road, Caringbah NSW 2229. Enware can also be contacted by telephone (1300 369 273) or by email (info@enware.com.au).

On receipt of a notification from you of a claim under this Warranty Statement, the relevant Supplier may contact you requesting you provide reasonably additional evidence, information or details about your claim, or requiring that the relevant Product should be returned to the Supplier (in accordance with the Supplier's instructions) for inspection and testing.

Your failure to comply with any such request within a reasonable amount of time may result in your claim under this Warranty Statement being rejected.

3. Our responsibilities

(a) In the event that the Supplier is reasonably satisfied that there is a defect in the relevant Product within the applicable Warranty Period, the Supplier will, at its option, replace the Product, supply an equivalent product or repair the Product, free of charge. Your costs in making a warranty claim under this Warranty Statement, including any costs in relation to freight, collection, delivery and installation, are to be borne and paid by you. However, if in respect of a Product, it is indicated in the Warranty Table that labour support will be provided, and the Supplier is reasonably satisfied that a defect in the Product takes place during the period that labour support will be provided as indicated in the Warranty Table, the Supplier will bear the costs for delivery, repair and installation of the replacement Product (as applicable).

(b) TO THE EXTENT PERMITTED BY LAW AND SUBJECT TO PARAGRAPH 4 BELOW AND THE OPERATION OF THE AUSTRALIAN CONSUMER LAW:

(i) THE WARRANTY SET OUT IN THIS WARRANTY STATEMENT IS GIVEN EXPRESSLY AND IS THE ONLY WARRANTY GIVEN BY THE SUPPLIER WITH RESPECT TO THE RELEVANT PRODUCT;

(ii) THE SUPPLIER MAKES NO OTHER WARRANTIES, EXPRESS OR IMPLIED;

(iii) THE SUPPLIER HEREBY SPECIFICALLY DISCLAIMS ALL OTHER WARRANTIES, EXPRESS OR IMPLIED, INCLUDING BUT NOT LIMITED TO, THE IMPLIED WARRANTIES OF MERCHANTABILITY AND FITNESS FOR A PARTICULAR PURPOSE; AND

(iv) THE REMEDY DESCRIBED IN THIS WARRANTY STATEMENT SHALL CONSTITUTE THE SOLE AND EXCLUSIVE REMEDY FOR BREACH OF WARRANTY, AND THE SUPPLIER SHALL NOT BE RESPONSIBLE FOR ANY INCIDENTAL, SPECIAL OR CONSEQUENTIAL DAMAGES, OR LOST PROFITS OR THE COST OF REPAIRING OR REPLACING OTHER PROPERTY WHICH IS DAMAGED IF THE PRODUCT DOES NOT WORK PROPERLY.

4. Australian Consumer Law

This paragraph 4 applies if you are a 'Consumer' (as defined in section 3 of the Australian Consumer Law (**ACL**)) and the Product or services supplied to you falls within the goods or services which, for the purposes of the ACL, are of a kind ordinarily acquired for personal, domestic or household use or consumption.

The Products and services provided by the Supplier come with guarantees that cannot be excluded under the ACL, and noting in this Warranty Statement should be interpreted as attempting to exclude, restrict or modify such guarantees or your rights under the ACL. For major failures with any services, you are entitled:

- (c) to cancel your service contract with us; and
- (d) to a refund for the unused portion, or to compensation for its reduced value.

You are also entitled to choose a refund or replacement for major failures with Products. If a failure with the Product or a service does not amount to a major failure, you are entitled to have the failure rectified in a reasonable time. If this is not done you are entitled to a refund for the Products and to cancel the contract for the service and obtain a refund of any unused portion. You are also entitled to be compensated for any other reasonably foreseeable loss or damage from a failure in the Products or service*.

5. Warranty table

*the applicable period commences on the date of purchase of the Product.

PRODUCT GROUP	PRODUCT SERIES CODES	WARRANTY PERIOD (YEARS)*	LABOUR SUPPORT (YEARS)
Sanitaryware	SPARE PARTS AND ACCESSORIES	2	0