

Slimline Front Panel Valve

- Elbow 1/4" BSP MI

Installation and Maintenance Instructions

LCN153NRDRY
LCN153NGAS
LCN153NOXY
LCN153NVAC
LCN153WATER



Enware products are to be installed in accordance with the Plumbing Code of Australia (PCA), AS/NZS3500, AS5601, AS2896 and other applicable local, national or state regulatory requirements or standards. Installations not complying with the above may void the product and performance warranty provisions.

Reference should also be made to the Australasian Health Facility Guidelines (AHFG), ABCB and Local Government regulations when considering the choice of, and the installation of these products.

This product must be installed and commissioned by a qualified plumber.

For use with potable water only.

NOTE: Enware Australia advises:

1. Due to ongoing Research and Development, specifications may change without notice.
2. Component specifications may change on some export models.

All measurements are in millimetres.

I00559_17 Apr 2024

1300 369 273 | info@enware.com.au | enware.com.au

ENWARE
A WATTS Brand

technical data

WATER FITTINGS

Working Pressure Range	Min 20 kPa Max 700 kPa
Maximum Static Pressure	1000 kPa
Maximum Working Temperature	90°C
Inlet Connection	1/2" BSP Male
Outlet Connection	Tube Nozzle/ 3/8" BSP Female (without nozzle)
Water Options	Cold, Hot, Chilled Water

DRY MEDIA FITTINGS

Maximum Working Pressure	Max 700 kPa (dry media)
Maximum Static Pressure	1000 kPa
Inlet Connection	1/2" BSP Male / 1/4" BSP Female
Outlet Connection	Tube Nozzle/ 3/8" BSP Female (without nozzle)
Dry Media Options	Argon, Carbogen, Carbon Dioxide, Compressed Air, Helium, Nitrogen, Oxygen, Vacuum

BURNING GAS FITTINGS

Maximum Working Pressure (Needle Valve)	700 kPa (burning gases)
Maximum Static Pressure	1000 kPa
Inlet Connection	1/2" BSP Male / 1/4" BSP Female
Outlet Connection	Tube Nozzle/ 3/8" BSP Female (without nozzle)
Burning Gas Options	Natural Gas, LPG

before installation

- All supply lines must be flushed thoroughly to remove debris prior to the installation of this product, as per AS/NZS 3500.1. Strainers (40 mesh) are recommended if debris is an ongoing problem.
- A pressure reduction valve may be required to comply with the recommended maximum supply pressure and/or balanced pressure requirements.

installation

1. Prepare 1 tap hole on mounting surface.
Drill hole size: 33mm diameter.
SEE IMAGE 01
2. Screw back nut onto tap body, and fit metal washer.
SEE IMAGE 02
3. Fit tap body through the tap hole from behind the panel.

Fit O-ring onto base flange, then from the front of panel, fit base flange onto the tap body. Screw the base flange on until it bottoms out. **SEE IMAGE 03**

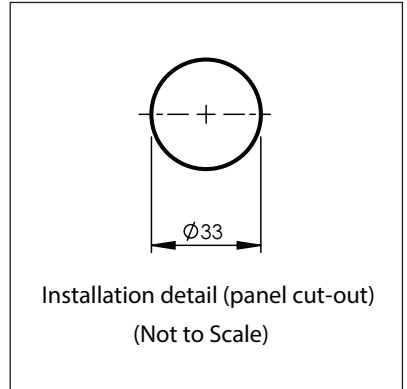

IMAGE 01

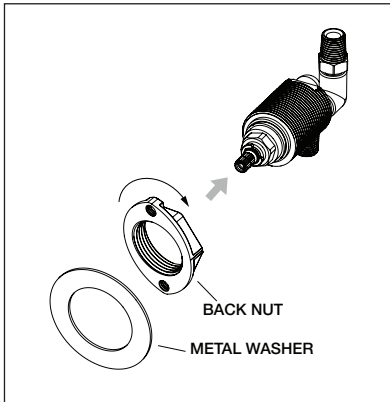

IMAGE 02

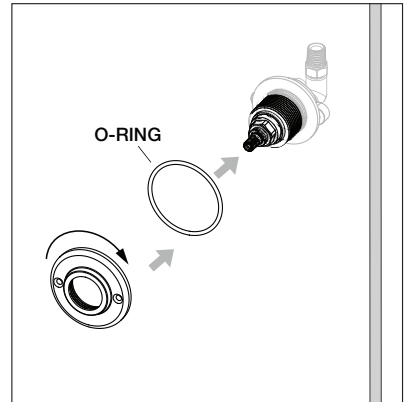

IMAGE 03

4. From behind the panel, turn the back nut further and hand-tighten. Fit the two screws onto fixing nut and tighten with a screwdriver to secure the tap in place. **SEE IMAGE 04**

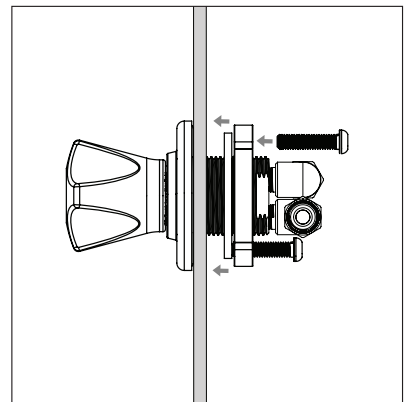

IMAGE 04

5. From the front, fit spline adaptor, handle and tooth washer, and fix in place using screw. Then fit the indicator button base onto handle by pushing until it clips into place. **SEE IMAGE 05**
6. On the back of tap body, connect water / gas supply to the inlet thread connection. Connect the outlet line to the outlet thread connection. (1/4" BSP male)
7. Turn on water / gas supply, test for correct operation and check for leaks.
8. Apply the ON-OFF indicator sticker onto the flange. **SEE IMAGE 06**
9. Apply indicator button onto handle. Ensure the surface of handle is clean and dry, free of dust, moisture and grease. Peel off the indicator button from its backing paper, taking care not to touch the adhesive side. Place the indicator button onto flat section of the button mount, and push the button firmly onto handle. **SEE IMAGE 07**

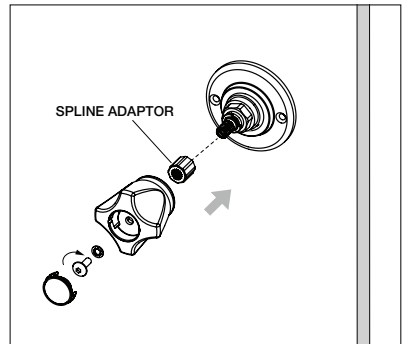

IMAGE 05

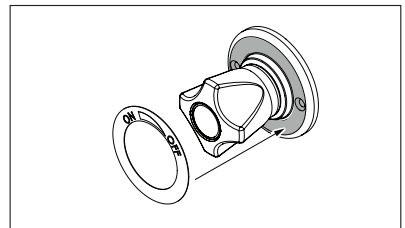

IMAGE 06

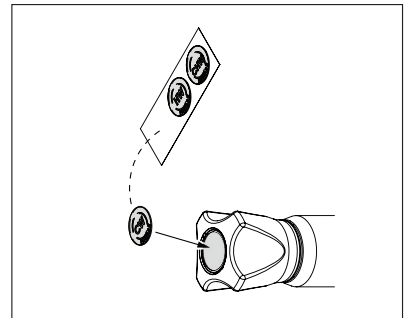

IMAGE 07

maintenance

CLEANING

Enware products should be cleaned with a soft damp cloth using only mild liquid detergent or soap and water. Do not use cleaning agents containing a corrosive acid, scouring agent or solvent chemicals. Do not use cream cleaners, as they are abrasive. Use of unsuitable cleaning agents may damage the surface. Any damage caused in this way will not be covered by warranty.

HANDLE & ACCESS TO SBA

To take off handle, use a hand tool to pop off the indicator button mount. Use a 3mm Allen key to remove fixing screw. Pull off handle to access the SBA. **SEE IMAGE 08 & 09**

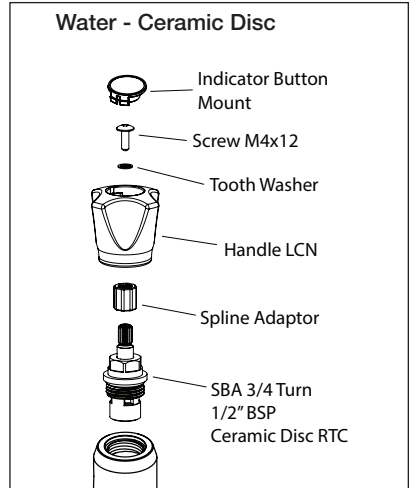

IMAGE 08

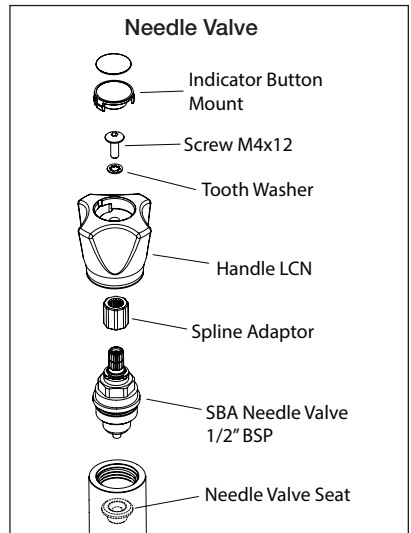
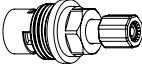







IMAGE 09

troubleshooting

PROBLEM	CAUSE	RECTIFICATION
Leaking from outlet Water dripping and does not shut off	SBA has debris caught in the mechanism.	Remove SBA and inspect. Remove debris and clean. Install an inline strainer / filter.
	Tap seat is damaged	Refurbish tap seat using a reseating tool. If necessary, fit reseating kit or replace tap body. Replace tap body.
	SBA / ceramic disc is worn or damaged	Replace SBA. Ensure the supply pressures are within the permitted range as specified in the Technical Data table.
Leaking from spindle	O-ring on SBA is worn or damaged	Replace O-ring. Replace SBA.
Water is not flowing from tap	Water turned off.	Turn water on.
Poor water flow from outlet	Aerator / Flow control is blocked by debris.	Remove flow control and clean debris. Install an inline strainer.

spare parts

	Description	Part Code
	SBA 3/4 Turn LCN 1/2" BSP ceramic disc	LCN183
	SBA Needle Valve LCN 1/2" BSP	LCN184
	Handle LCN (Green, Blue, Yellow, Grey, Red, Black, Chrome, White)	LCN191-GREEN LCN191-BLUE LCN191-YELLOW LCN191-GREY LCN191-RED LCN191-BLACK LCN191-CHROME LCN191-WHITE
	Indicator button mount - Green Indicator button mount - Blue Indicator button mount - Yellow Indicator button mount - Grey Indicator button mount - Red Indicator button mount - Black	LCN193-1 LCN193-2 LCN193-3 LCN193-4 LCN193-5 LCN193-6
	Indicator button (adhesive) Dry Media (specify media)	LCN181
	Indicator button (adhesive) Cold Water	LCN182

product warranty statement - WATTS AUSTRALIA

EFFECTIVE FROM 20 November 2023

This Warranty Statement applies to products supplied by Australian Valve Group Pty Ltd (ACN 068 227 270) (**AVG**) or Enware Pty Ltd (ACN 662 302 767) (**Enware**) (each of AVG and Enware, a Supplier) and installed within Australia.

Subject to the terms and conditions outlined in this Warranty Statement, each Supplier warrants to its customers that a product supplied by it (**Product**) will be free from all defects in material and workmanship under normal usage for the applicable Warranty Period (as set out in the Warranty Table below). The Warranty Period commences from the date of delivery of the relevant Product.

1. Conditions

The warranty provided under this Warranty Statement will not apply in respect of a Product (or any Product defect, fault or resulting damage) if:

- (a) the Product is not installed and maintained in accordance with the requirements of the applicable laws, standards and codes (including, without limitation to, the National Construction Code Volume Three – Plumbing Code of Australia, associated reference standards as applicable at the time and AS/NZS 3500);
- (b) the Product is not installed and maintained by a qualified technician in accordance with the relevant installation and operation manual and instructions; and
- (c) any Product defect, faulty or resulting damage arises from:
 - (i) failure by you or any other person to follow the relevant manual or instructions (relating to the handling, storage, installation, fitting, connection, adjustment, maintenance or repair of the Product) published or provided by the Supplier;
 - (ii) failure by you or any other person responsible for the fitting, installation, or other work on the Product to follow or conform to applicable laws, standards and codes (including, without limitation to, the AS/NZ 3500 set of Standards, all applicable State and Territory Plumbing Codes, the Plumbing Code of Australia and directions and requirements of local and other statutory authorities);
 - (iii) any parts or components not manufactured by the Supplier (or otherwise not authorised by the Supplier) are installed or combined with the Product, without the prior authorisation of the Supplier; or
 - (iv) any act or circumstance beyond our control including, without limitation to, accident, abnormal use, vandalism, fouling caused by foreign material, damage from adverse water conditions, chemical, acts of God, damage to buildings, other structures and infrastructure and loss or damage during transit or transportation of the Product, or any abuse, misuse, misapplication, improper installation or connection, or improper maintenance or alteration of the Product.

2. Make a claim

To make a claim under this Warranty Statement, you must notify the relevant Supplier in writing within 7 days of any alleged defect in the Product coming to your attention and provide the Supplier with proof of your purchase of the Product to the relevant Supplier:

- (a) If the Product is supplied by **AVG**, please contact AVG by telephone at 1800 284 287, or by email via its online portal <https://www.wattsau.com.au/support>.
- (b) If the Product is supplied by **Enware**, please complete the Product Service Request form (ENF091), which is available on request from our office (see contact details below), or online via <https://www.enware.com.au/warranty-service-form/>. All notifications and accompanying forms must be sent to Enware marked for the attention of Enware, 9 Endeavour Road, Caringbah NSW 2229. Enware can also be contacted by telephone (1300 369 273) or by email (info@enware.com.au).

On receipt of a notification from you of a claim under this Warranty Statement, the relevant Supplier may contact you requesting you provide reasonably additional evidence, information or details about your claim, or requiring that the relevant Product should be returned to the Supplier (in accordance with the Supplier's instructions) for inspection and testing.

Your failure to comply with any such request within a reasonable amount of time may result in your claim under this Warranty Statement being rejected.

3. Our responsibilities

(a) In the event that the Supplier is reasonably satisfied that there is a defect in the relevant Product within the applicable Warranty Period, the Supplier will, at its option, replace the Product, supply an equivalent product or repair the Product, free of charge. Your costs in making a warranty claim under this Warranty Statement, including any costs in relation to freight, collection, delivery and installation, are to be borne and paid by you. However, if in respect of a Product, it is indicated in the Warranty Table that labour support will be provided, and the Supplier is reasonably satisfied that a defect in the Product takes place during the period that labour support will be provided as indicated in the Warranty Table, the Supplier will bear the costs for delivery, repair and installation of the replacement Product (as applicable).

(b) TO THE EXTENT PERMITTED BY LAW AND SUBJECT TO PARAGRAPH 4 BELOW AND THE OPERATION OF THE AUSTRALIAN CONSUMER LAW:

- (i) THE WARRANTY SET OUT IN THIS WARRANTY STATEMENT IS GIVEN EXPRESSLY AND IS THE ONLY WARRANTY GIVEN BY THE SUPPLIER WITH RESPECT TO THE RELEVANT PRODUCT;
- (ii) THE SUPPLIER MAKES NO OTHER WARRANTIES, EXPRESS OR IMPLIED;
- (iii) THE SUPPLIER HEREBY SPECIFICALLY DISCLAIMS ALL OTHER WARRANTIES, EXPRESS OR IMPLIED, INCLUDING BUT NOT LIMITED TO, THE IMPLIED WARRANTIES OF MERCHANTABILITY AND FITNESS FOR A PARTICULAR PURPOSE; AND
- (iv) THE REMEDY DESCRIBED IN THIS WARRANTY STATEMENT SHALL CONSTITUTE THE SOLE AND EXCLUSIVE REMEDY FOR BREACH OF WARRANTY, AND THE SUPPLIER SHALL NOT BE RESPONSIBLE FOR ANY INCIDENTAL, SPECIAL OR CONSEQUENTIAL DAMAGES, OR LOST PROFITS OR THE COST OF REPAIRING OR REPLACING OTHER PROPERTY WHICH IS DAMAGED IF THE PRODUCT DOES NOT WORK PROPERLY.

4. Australian Consumer Law

This paragraph 4 applies if you are a 'Consumer' (as defined in section 3 of the Australian Consumer Law (**ACL**)) and the Product or services supplied to you falls within the goods or services which, for the purposes of the ACL, are of a kind ordinarily acquired for personal, domestic or household use or consumption.

The Products and services provided by the Supplier come with guarantees that cannot be excluded under the ACL, and noting in this Warranty Statement should be interpreted as attempting to exclude, restrict or modify such guarantees or your rights under the ACL. For major failures with any services, you are entitled:

- (c) to cancel your service contract with us; and
- (d) to a refund for the unused portion, or to compensation for its reduced value.

You are also entitled to choose a refund or replacement for major failures with Products. If a failure with the Product or a service does not amount to a major failure, you are entitled to have the failure rectified in a reasonable time. If this is not done you are entitled to a refund for the Products and to cancel the contract for the service and obtain a refund of any unused portion. You are also entitled to be compensated for any other reasonably foreseeable loss or damage from a failure in the Products or service*.

5. Warranty table

*the applicable period commences on the date of delivery of the Product.

PRODUCT GROUP	PRODUCT SERIES CODES	WARRANTY PERIOD (YEARS)*	LABOUR SUPPORT (YEARS)
Commercial Lab and Gas Turrets	LCN/LC/LF	5	3