

LEVA Sequential Basin Mixer

The LEVA Sequential Basin Mixer is a new concept in Single Lever Type Mixers, designed specifically for use in Health and Aged Care premises, but makes an attractive and durable addition to any commercial bathroom.

The standard 80mm lever operates a sequential ceramic cartridge that does not require a "lift" motion, and turns progressively from off, to cold, to mixed with a subtle click indicator at each point to assist the user. This feature ensures the mixer is easy to use and control as well as reducing hot water consumption and potentially reducing the risk of legionella.

The higher profile of the mixer and the longer spout provide easier access for effective handwashing. The spout can be removed for disinfection and the extended length ensures that the water stream does not flow directly into the basin waste, reducing the risk of airborne bacteria.

Matches perfectly with the Aquablend Health TMV with Four Way Mixer.

FEATURES

- Sequential Ceramic Disc Mixing Cartridge ensures ultimate control with cold start up and stop
- "CLICK" at Off, Cold and Mixed positions
- Removable spout allows disinfection
- Neoperl Soft-Pex inlet pipes provide long term reliability
- Colour indicators for Hot/ Warm, Cold and Off
- Attractive, solid brass chrome body and 80mm Leva Handle ensures ease of use and cleaning
- Laminar flow aerator reducing the risk of airborne bacteria
- 150mm Lever Handle option available for AS1428/ ADA and Elbow operation applications

Product Codes

LEV80306SQ LEVA Sequential Basin Mixer - 80mm Lever

OPTIONS

LEV150306SQ LEVA Sequential Basin Mixer - 150mm Lever

Technical Information

| | |
|------------------------------|--------------|
| Working Pressure Range | 50-800 kPa |
| Recommended Maximum Pressure | 500 kPa* |
| Working Temperature Range | 5°C – 85°C * |

Enware products are to be installed in accordance with the Plumbing Code of Australia and AS/NZS3500.

Reference should also be made to the Australasian Health facility Guidelines (AHFG), ABCB and Local Government regulations when considering the choice of, and the installation of these products.

NOTE: Enware Australia advises: 1. Due to ongoing Research and Development, specifications may change without notice. 2. Component specifications may change on some export models.

LEV80306SQ

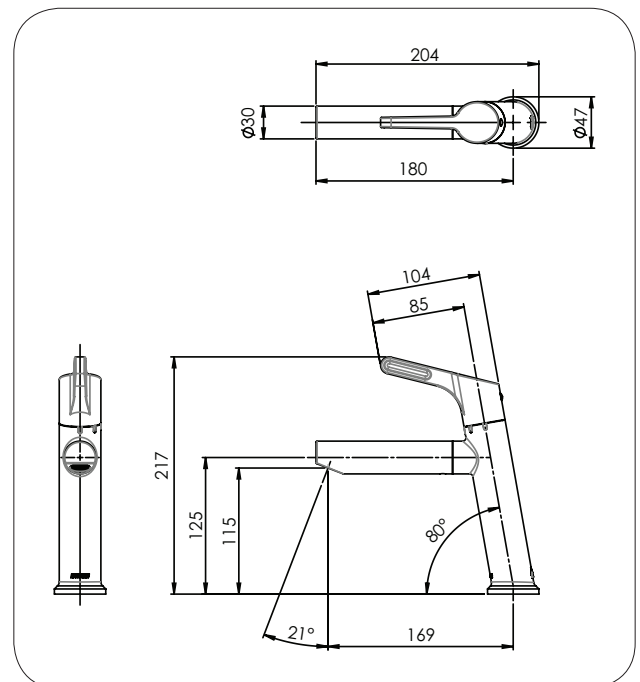

Version: Jan 20

Call 1300 369 273
www.enware.com.au

Enware Australia Pty Limited
9 Endeavour Rd Caringbah NSW 2229 Australia
Ph: 02 8536 4000 info@enware.com.au

