

Cache Wall Mounted Spout

Installation and Maintenance Instructions

SPC110 **SPC126**
SPC111 **SPC126R**
SPC120 **SPC192**
SPC121



technical data

Working Pressure Range	Min 50 kPa Max 500 kPa
Maximum Working Temperature	70°C
Flow Rate	8 L/min (WELS 3 Star) 6 L/min (WELS 5 Star) 3.5 L/min (WELS 6 Star)
Inlet Connection	1/2" BSP (15mm) Female

Enware products are to be installed in accordance with the Plumbing Code of Australia (PCA) and AS/NZS3500. Installations not complying with PCA and AS/NZS 3500 may void the product and performance warranty provisions.

Reference should also be made to the Australasian Health Facility Guidelines (AHFG), ABCB and Local Government regulations when considering the choice of, and the installation of these products.

This product must be installed and commissioned by a qualified plumber.

For use with potable water only.

NOTE: Enware Australia advises:

1. Due to ongoing Research and Development, specifications may change without notice.
2. Component specifications may change on some export models.

I00584_26 May 2025

Rev. A.2

1300 369 273 | info@enware.com.au | enware.com.au

ENWARE
A WATTS Brand

installation

- Ensure all supply lines are flushed thoroughly to remove debris prior to the installation of this product. Strainers (40 mesh) are recommended if debris is an ongoing problem.
- A pressure reduction valve may be required to comply with the recommended maximum supply pressure requirements.

INSTALLATION

1. Prepare 1/2" BSP male thread inlet point on wall. Allow for 17mm of thread protruding from finished wall. **SEE IMAGE 01**
2. Seal any gaps between thread and wall with silicone sealant. Apply thread sealant to the inlet thread connection on wall. **SEE IMAGE 02**
3. If the spout is assembled, take grub screw out from the wall base using a 2.5mm Allen key, and keep at hand. Pull spout out from the wall base and keep at hand.
4. Screw wall base onto the 1/2" thread, and tighten firmly. Fit an 11mm Allen key through the swivel to tighten. Ensure the wall base faces straight up. **SEE IMAGE 02**

FITTING SPOUT TO WALL BASE

5. Using 2.5mm Allen key, take grub screw out from the wall base, and keep at hand. **SEE IMAGE 03**
6. Note that the spout uses a double O-ring spigot connection. The O-rings on the male spigot are pre-greased. Re-grease them if required.
7. Fit spout onto wall base. To do this, firstly align the joints straight, then gently but firmly push the male spigot into the wall base, taking care not to pinch or damage the O-rings while doing so. Push the joints together all the way until the male spigot comes to a stop. **SEE IMAGE 04**
8. Fit grub screw back onto wall base. Check that the grub screw has engaged into the groove of the male spigot, then tighten using 2.5mm Allen key.
To allow the spout to swivel, tighten grub screw and then back off slightly just enough for the spout to swivel. Do not disengage screw more than half a turn. If grub screw is not fitted correctly it may result in premature wear or damage to the brass spigot.

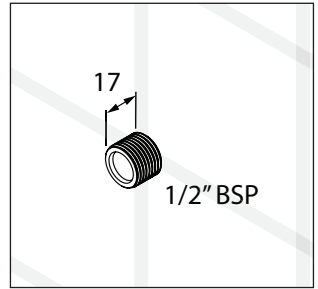

IMAGE 01

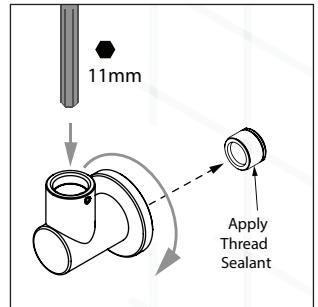

IMAGE 02

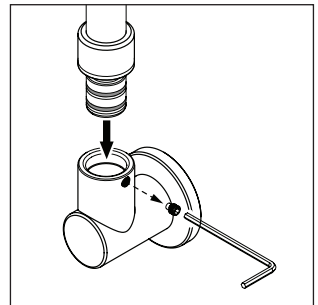

IMAGE 03

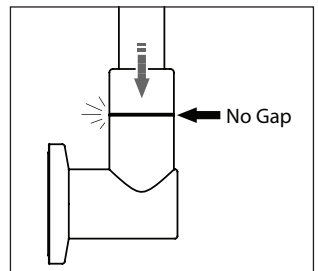

IMAGE 04

maintenance

CLEANING

Enware products should be cleaned with a soft damp cloth using only mild liquid detergent or soap and water. Do not use cleaning agents containing a corrosive acid, scouring agent or solvent chemicals. Do not use cream cleaners, as they are abrasive. Use of unsuitable cleaning agents may damage the surface. Any damage caused in this way will not be covered by warranty.

AERATOR

Spout aerator should be checked periodically for debris. Use Aerator Key to unscrew spout aerator. If aerator doesn't come out completely, turn tap on to flush the aerator out.

Inspect and reverse rinse aerator to clear any debris. Replace aerator if necessary.

To fit aerator back, insert aerator into tip of spout using care to avoid damage to the aerator O-ring by ensuring the aerator is square to the spout outlet, and finger tighten half a turn. Use Aerator Key to tighten aerator into position. Do not overtighten.

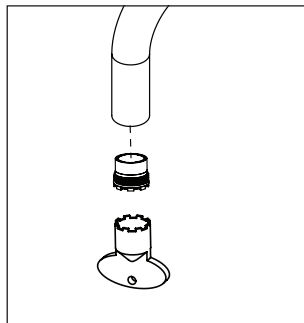

IMAGE 06

spare parts

PART	ENWARE SALES CODE
Aerator with key - 8 L/min (Cache TT)	SPC301
Aerator laminar insert with key - 8 L/min (Cache TT)	SPC301LF
Aerator laminar insert with key - 5 L/min (Cache TT)	SPC302LF
Aerator lamniar insert - 4 L/min	SPC303LF

troubleshooting

PROBLEM	CAUSE	RECTIFICATION
Poor water flow	Aerator is blocked by debris	Unscrew aerator and clean / reverse rinse. Install an inline strainer.
Leaking from thread connection	Thread seal failed	Re-install tail onto spout with appropriate thread sealant.

product warranty statement - WATTS AUSTRALIA

EFFECTIVE FROM 20 November 2023

This Warranty Statement applies to products supplied by Australian Valve Group Pty Ltd (ACN 068 227 270) (**AVG**) or Enware Pty Ltd (ACN 662 302 767) (**Enware**) (each of AVG and Enware, a Supplier) and installed within Australia.

Subject to the terms and conditions outlined in this Warranty Statement, each Supplier warrants to its customers that a product supplied by it (**Product**) will be free from all defects in material and workmanship under normal usage for the applicable Warranty Period (as set out in the Warranty Table below). The Warranty Period commences from the date of delivery of the relevant Product.

1. Conditions

The warranty provided under this Warranty Statement will not apply in respect of a Product (or any Product defect, fault or resulting damage) if:

- (a) the Product is not installed and maintained in accordance with the requirements of the applicable laws, standards and codes (including, without limitation to, the National Construction Code Volume Three – Plumbing Code of Australia, associated reference standards as applicable at the time and AS/NZS 3500);
- (b) the Product is not installed and maintained by a qualified technician in accordance with the relevant installation and operation manual and instructions; and
- (c) any Product defect, faulty or resulting damage arises from:
 - (i) failure by you or any other person to follow the relevant manual or instructions (relating to the handling, storage, installation, fitting, connection, adjustment, maintenance or repair of the Product) published or provided by the Supplier;
 - (ii) failure by you or any other person responsible for the fitting, installation, or other work on the Product to follow or conform to applicable laws, standards and codes (including, without limitation to, the AS/NZ 3500 set of Standards, all applicable State and Territory Plumbing Codes, the Plumbing Code of Australia and directions and requirements of local and other statutory authorities);
 - (iii) any parts or components not manufactured by the Supplier (or otherwise not authorised by the Supplier) are installed or combined with the Product, without the prior authorisation of the Supplier; or
 - (iv) any act or circumstance beyond our control including, without limitation to, accident, abnormal use, vandalism, fouling caused by foreign material, damage from adverse water conditions, chemical, acts of God, damage to buildings, other structures and infrastructure and loss or damage during transit or transportation of the Product, or any abuse, misuse, misapplication, improper installation or connection, or improper maintenance or alteration of the Product.

2. Make a claim

To make a claim under this Warranty Statement, you must notify the relevant Supplier in writing within 7 days of any alleged defect in the Product coming to your attention and provide the Supplier with proof of your purchase of the Product to the relevant Supplier:

- (a) If the Product is supplied by **AVG**, please contact AVG by telephone at 1800 284 287, or by email via its online portal <https://www.wattsau.com.au/support>.
- (b) If the Product is supplied by **Enware**, please complete the Product Service Request form (ENF091), which is available on request from our office (see contact details below), or online via <https://www.enware.com.au/warranty-service-form/>. All notifications and accompanying forms must be sent to Enware marked for the attention of Enware, 9 Endeavour Road, Caringbah NSW 2229. Enware can also be contacted by telephone (1300 369 273) or by email (info@enware.com.au).

On receipt of a notification from you of a claim under this Warranty Statement, the relevant Supplier may contact you requesting you provide reasonably additional evidence, information or details about your claim, or requiring that the relevant Product should be returned to the Supplier (in accordance with the Supplier's instructions) for inspection and testing.

Your failure to comply with any such request within a reasonable amount of time may result in your claim under this Warranty Statement being rejected.

3. Our responsibilities

(a) In the event that the Supplier is reasonably satisfied that there is a defect in the relevant Product within the applicable Warranty Period, the Supplier will, at its option, replace the Product, supply an equivalent product or repair the Product, free of charge. Your costs in making a warranty claim under this Warranty Statement, including any costs in relation to freight, collection, delivery and installation, are to be borne and paid by you. However, if in respect of a Product, it is indicated in the Warranty Table that labour support will be provided, and the Supplier is reasonably satisfied that a defect in the Product takes place during the period that labour support will be provided as indicated in the Warranty Table, the Supplier will bear the costs for delivery, repair and installation of the replacement Product (as applicable).

(b) TO THE EXTENT PERMITTED BY LAW AND SUBJECT TO PARAGRAPH 4 BELOW AND THE OPERATION OF THE AUSTRALIAN CONSUMER LAW:

- (i) THE WARRANTY SET OUT IN THIS WARRANTY STATEMENT IS GIVEN EXPRESSLY AND IS THE ONLY WARRANTY GIVEN BY THE SUPPLIER WITH RESPECT TO THE RELEVANT PRODUCT;
- (ii) THE SUPPLIER MAKES NO OTHER WARRANTIES, EXPRESS OR IMPLIED;
- (iii) THE SUPPLIER HEREBY SPECIFICALLY DISCLAIMS ALL OTHER WARRANTIES, EXPRESS OR IMPLIED, INCLUDING BUT NOT LIMITED TO, THE IMPLIED WARRANTIES OF MERCHANTABILITY AND FITNESS FOR A PARTICULAR PURPOSE; AND
- (iv) THE REMEDY DESCRIBED IN THIS WARRANTY STATEMENT SHALL CONSTITUTE THE SOLE AND EXCLUSIVE REMEDY FOR BREACH OF WARRANTY, AND THE SUPPLIER SHALL NOT BE RESPONSIBLE FOR ANY INCIDENTAL, SPECIAL OR CONSEQUENTIAL DAMAGES, OR LOST PROFITS OR THE COST OF REPAIRING OR REPLACING OTHER PROPERTY WHICH IS DAMAGED IF THE PRODUCT DOES NOT WORK PROPERLY.

4. Australian Consumer Law

This paragraph 4 applies if you are a 'Consumer' (as defined in section 3 of the Australian Consumer Law (**ACL**)) and the Product or services supplied to you falls within the goods or services which, for the purposes of the ACL, are of a kind ordinarily acquired for personal, domestic or household use or consumption.

The Products and services provided by the Supplier come with guarantees that cannot be excluded under the ACL, and noting in this Warranty Statement should be interpreted as attempting to exclude, restrict or modify such guarantees or your rights under the ACL. For major failures with any services, you are entitled:

- (c) to cancel your service contract with us; and
- (d) to a refund for the unused portion, or to compensation for its reduced value.

You are also entitled to choose a refund or replacement for major failures with Products. If a failure with the Product or a service does not amount to a major failure, you are entitled to have the failure rectified in a reasonable time. If this is not done you are entitled to a refund for the Products and to cancel the contract for the service and obtain a refund of any unused portion. You are also entitled to be compensated for any other reasonably foreseeable loss or damage from a failure in the Products or service*.

5. Warranty table

*the applicable period commences on the date of delivery of the Product.

PRODUCT GROUP	PRODUCT SERIES CODES	WARRANTY PERIOD (YEARS)*	LABOUR SUPPORT (YEARS)
General Tapware, Spouts & Outlets-Chrome Plated	SP	10	2