

The Custodian® Smart Board

Installation and Maintenance Instructions

WMSSB-000 - without solenoids

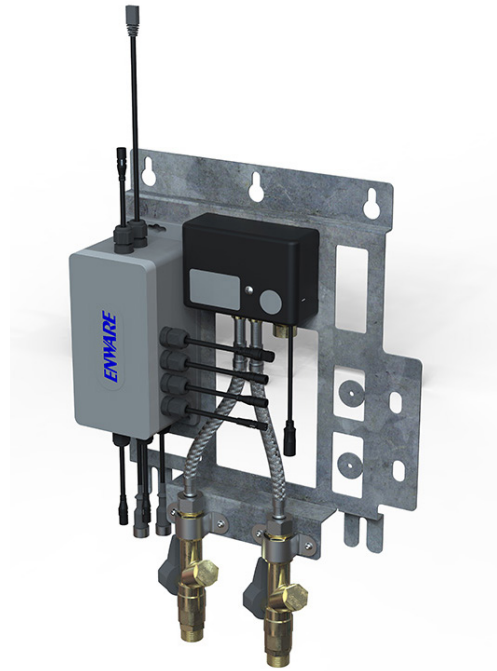

WMSSB-001 - with solenoids



I00348_FEB 23

Call 1300 369 273
www.enware.com.au

Enware Australia
9 Endeavour Rd Caringbah NSW 2229 Australia
Ph: 02 8536 4000 info@enware.com.au

 ENWARE

product description

The Custodian® Smart Board directly controls and monitors the delivery of water in secure or controlled bathroom environments. The compact and easy to install unit houses the Electronic Thermostatic Mixing Valve (eTMV), eTMV Control Hub, service isolation/ strainers and check valves. WMSSB-001 model additionally includes basin and shower solenoids.

Features:

- Rapid installation of pre-assembled and tested plumbing assembly
- Integrated control of water flow and thermostatic temperature control of shower and basin
- Toilet full and half flush connections
- Plug-and-play cable connectors for all fixtures and Smartflow Water Management System

The eTMV Control Hub is designed to be a generic smart hardware platform which is used for multiple applications such as shower and basin tapware and toilet flush valves in domestic / public / aged care / hospital / detention plumbing systems depending on the configuration. The hub has a RS485 network interface to connect to either a local or cloud based water management system. The network connection allows the hub to be configured, monitored and updated remotely.

When activated, water is delivered to the shower or basin outlet at the selected thermostatic temperature and for a pre-configured runtime. This is achieved by using an Electronic Thermostatic Mixing Valve (eTMV) for temperature control and a solenoid for flow control. The available activation methods depend on the configured mode.

The Custodian® Smart Board

(WMSSB-001 Model)

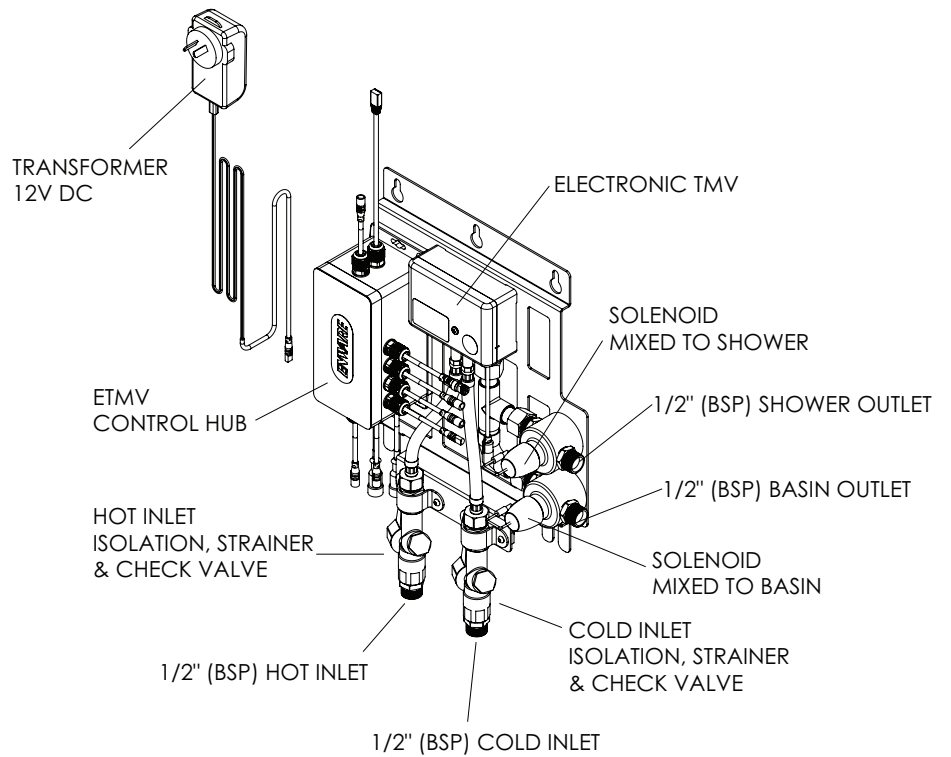

(WMSSB-001 Model)

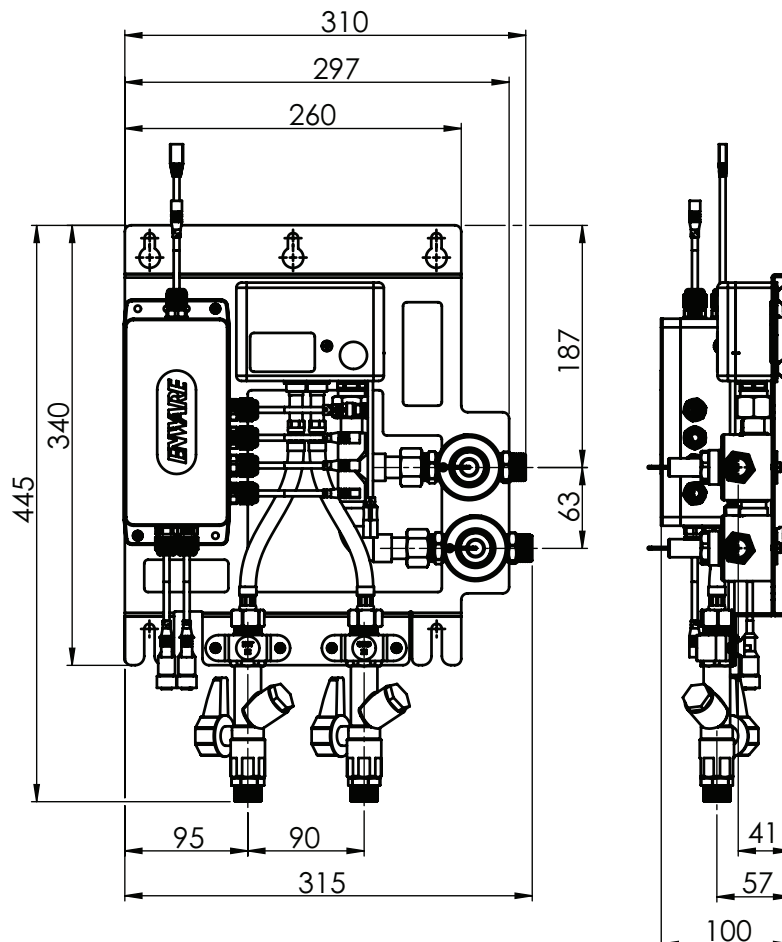

All measurements are in millimetres.

technical data - electronic tmv

Electronic Thermostatic Mixing Valve (eTMV)

Water Supply	
Inlet Temperatures	Cold: Min. 5°C Max. 30°C Hot: Min. 55°C Max. 85 °C
Outlet Temperature Range (Temperature limits and settings controlled by Smartflow System)	Min. 5 °C Max. 50 °C (+/- 2°C)
Thermal Flush Temperature (Temporarily enabled by server, activated on site)	Max. 70 °C
Dynamic Inlet Pressures	Min. 100 kPa Max. 500 kPa
Dynamic Pressure Differential Between Hot and Cold Supplies	Must be less than 100 kPa*
Static Inlet Pressure For Testing Purposes / System Commissioning	Max. 1600kPa
Minimum Flow Rate	2 Litres/min
Maximum Flow Rate	32 Litres/min @ 300 kPa pressure loss as per flow sizing graph
Inlet & Outlet Connections	1/2" BSP Male

*AS3500.4 clause 1.9.4.2 - The dynamic pressure differential between hot and cold supplies when mixed at a thermostatic mixing valve shall not exceed 10%.

eTMV Flow Sizing Graph

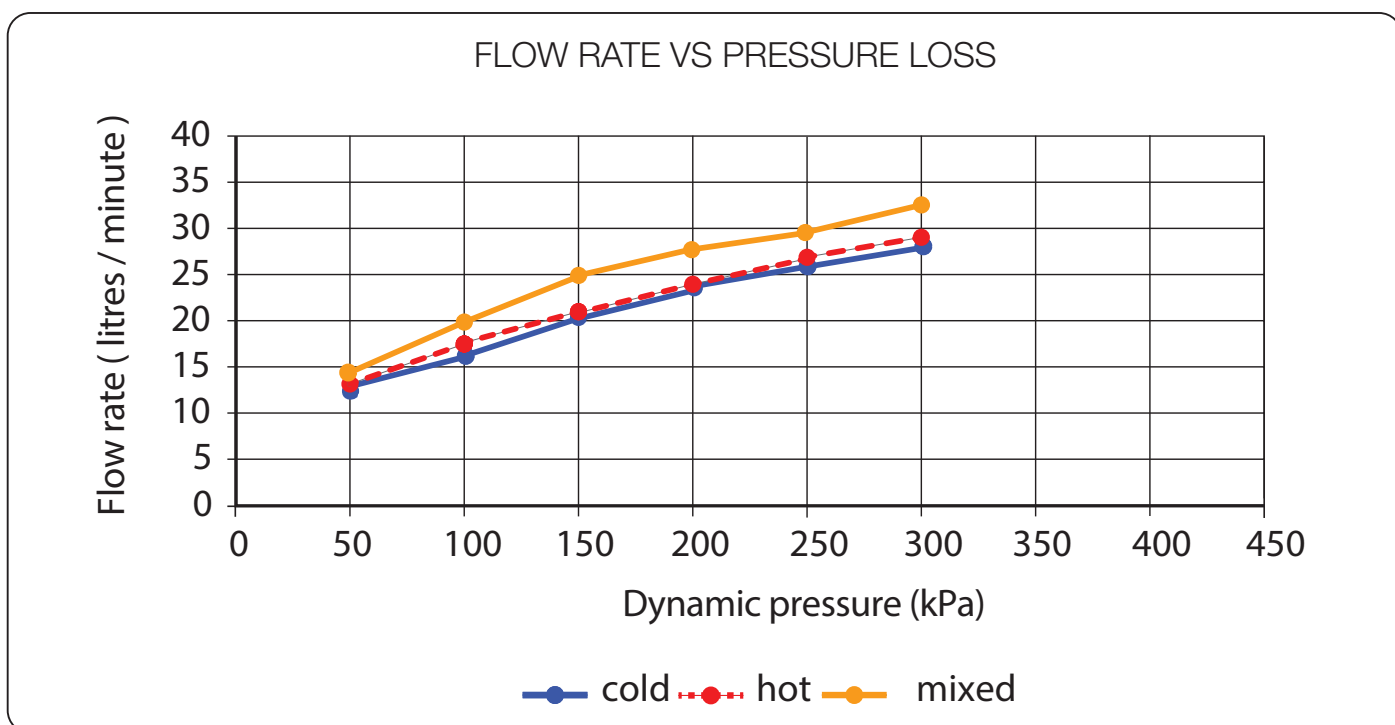

technical data - eTMV control hub

eTMV Control Hub

Power	
Included Power Supply Input Requirements	100-240VAC 50/60Hz
Nominal Input Voltage	12VDC
Input Voltage Tolerance	10%
Typical Power Consumption	1W
Maximum Power Consumption	36W
Environmental Specifications	
Heat Output (BTU/HR)	3.4
Operating Temperature	5 - 50 °C
Communication Ports	
Type of Port	Smartflow Communication Port
Number of Connectors	1
Serial Port Protocol	RS485
Serial Port Speed	38400 baud
Piezo Button Ports	
Number of Inputs	4
Type of Inputs	Piezo Buttons
Number of Connectors	2
Type of Connector	KCC SK5/5 Male
TLI Control Wheel Port	
Number of Connectors	2
Type of Connector	KCC SK9/8 Male
Flushing Solenoid Ports	
Number of Outputs	1
Type of Outputs	10W solenoid
Voltage of Outputs	12V
Number of Connectors	1
Connector Type	KCC SK2/2 Female

installation compliance

Enware products are to be installed in accordance with the Plumbing Code of Australia (PCA) and AS/NZS3500. Installations not complying with PCA and AS/NZS 3500 may void the product and performance warranty provisions.

Reference should also be made to the Australasian Health Facility Guidelines (AHFG), ABCB and Local Government regulations when considering the choice of, and the installation of these products.

NOTE: Enware Australia advises:

1. Due to ongoing Research and Development, specifications may change without notice.
2. Component specifications may change on some export models.

For use with potable water only.

installation

1. The Custodian® Smart Board should be securely fixed to a wall in close proximity to the interface facia plate(s), flushing solenoid, and within 1m of a 240VAC GPO ideally located above the Smart Board.

It should be placed in a clean dry environment, in an access duct or service duct or some other appropriate location where it can be accessed for servicing.

Fix Smart Board to a wall, using appropriate screws. SEE IMAGE 01

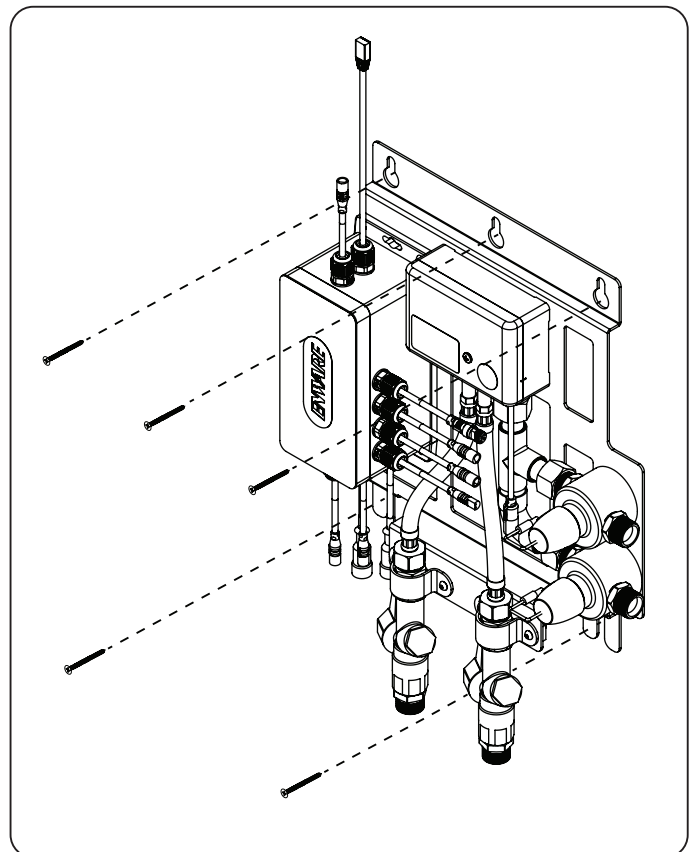

IMAGE 01

2. Flush water supply lines and ensure the lines are clear of any debris.
3. Connect water lines to each connection.
SEE IMAGE 02

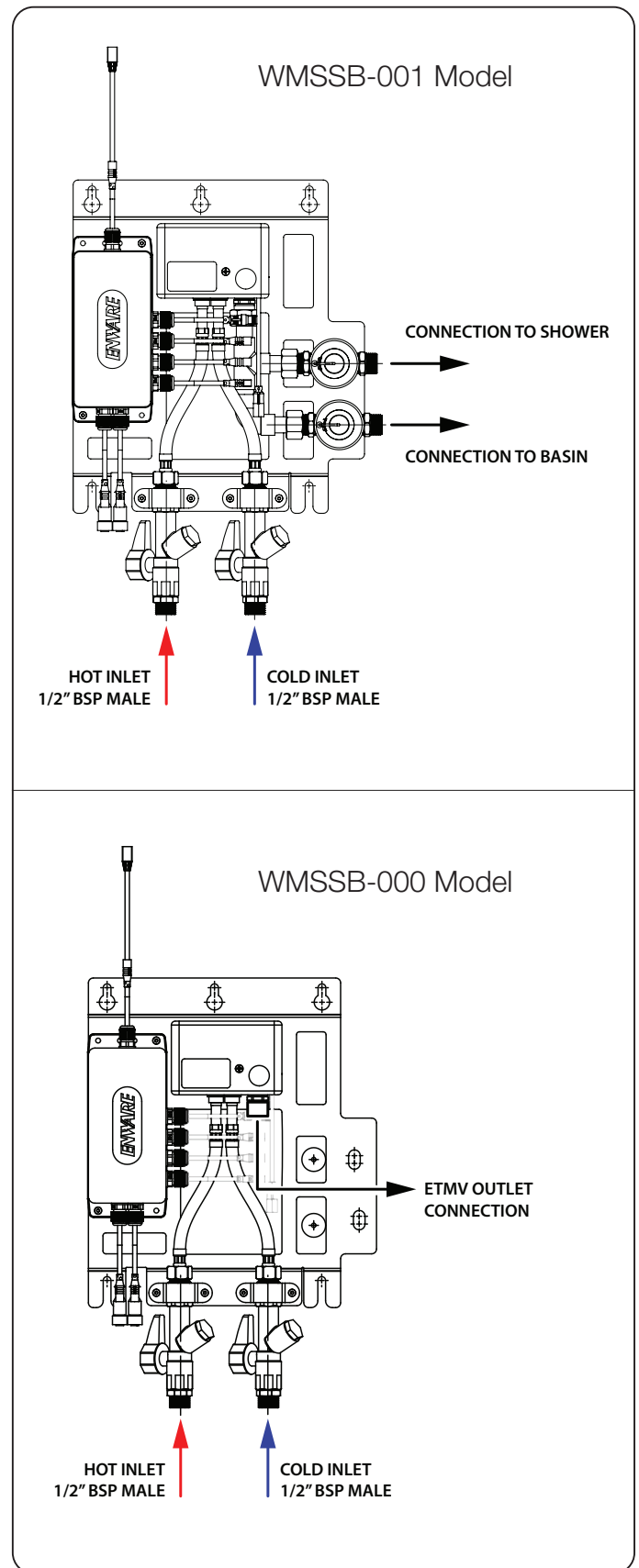

IMAGE 02

eTMV Control Hub Cable Connections

1. Connect cable connections for the control plate(s) and flushing solenoid to eTMV Control Hub.

The cable connections should be plugged into the eTMV Control Hub in the location marked with the same designator - e.g. “w1” should be connected to the other cable labeled “w1”.

Care should be taken with the position and orientation of the connections. Align white marking on the connectors when connecting. When unplugging cables, hold the cable connectors themselves, and do not pull on the cables.

Follow the installation instructions for eTMV Control Panel for correct cable connections.

2. Connect RJ45 Network cable to the surface mount RJ45 Jack.

The main Backbone Cable will have already been installed and a surface mount RJ45 Jack will be fitted less than 1m above the Custodian Smart Board location.

3. Finally connect the power supply (supplied transformer) to power the Custodian® Smart Board.

Control Hub Overview

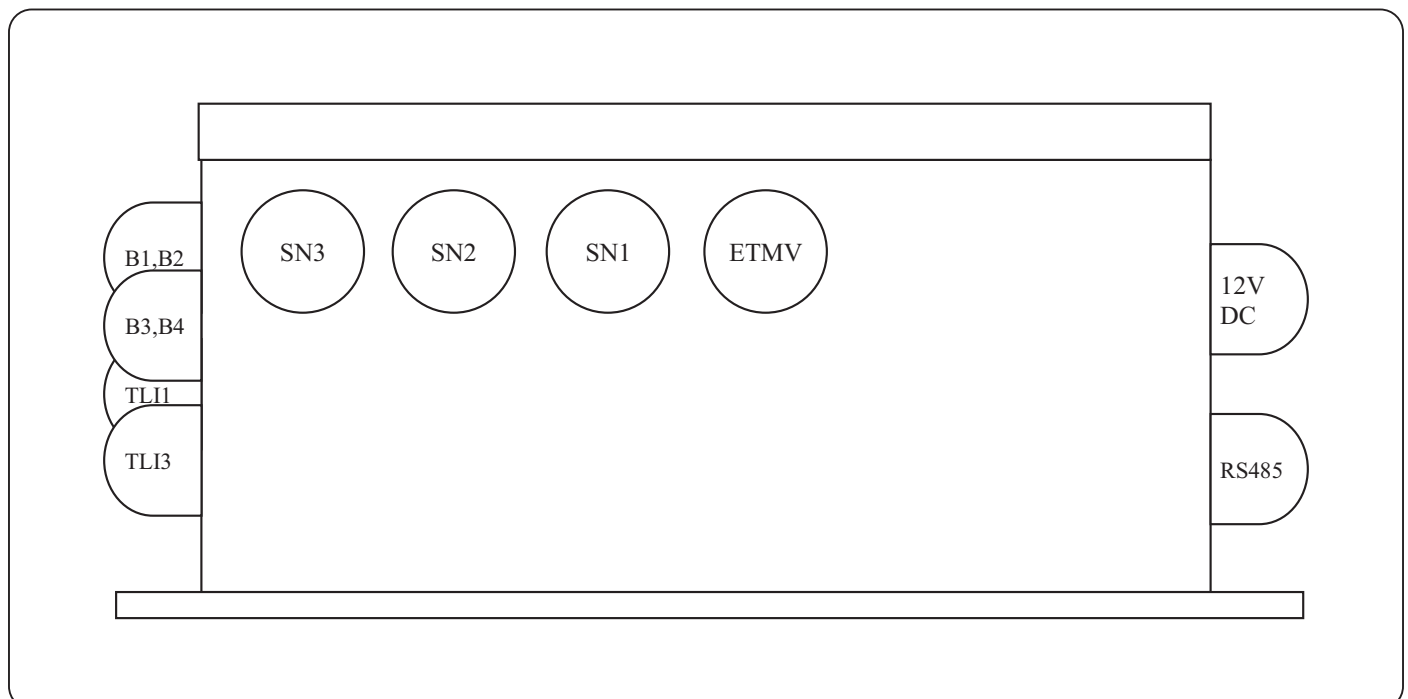

eTMV Control Hub Connections

- 1x RJ45 network cable for communications and updates (external)
- 1x power supply input (external)
- 4x piezo button inputs (external)
- 2x TLI control wheels (external)
- 1x ETMV output (on Smart Board)
- 2x shower / basin solenoid outputs (on Smart Board)
- 1x flushing solenoid output (external)

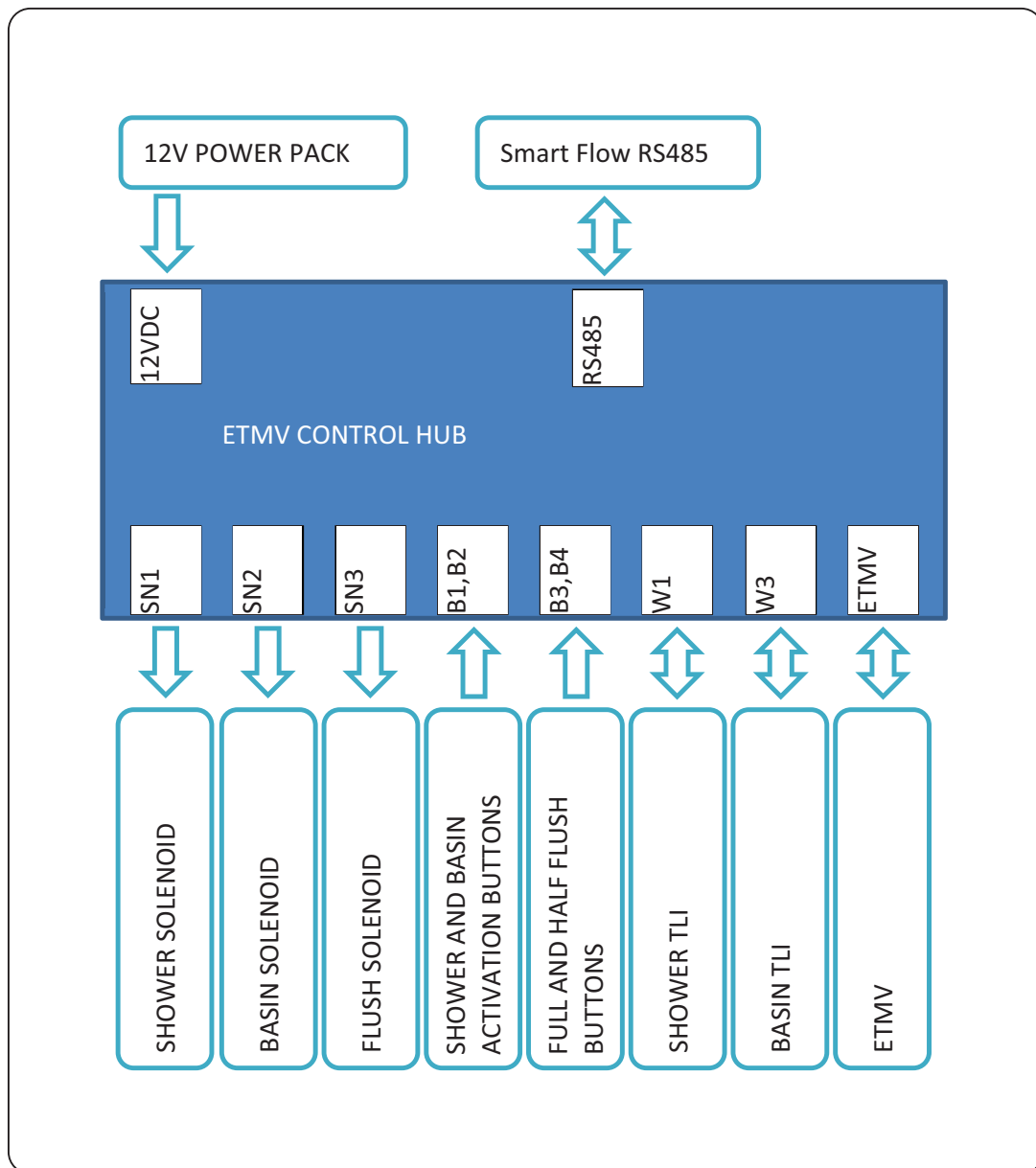

operation

CONTROL PANEL

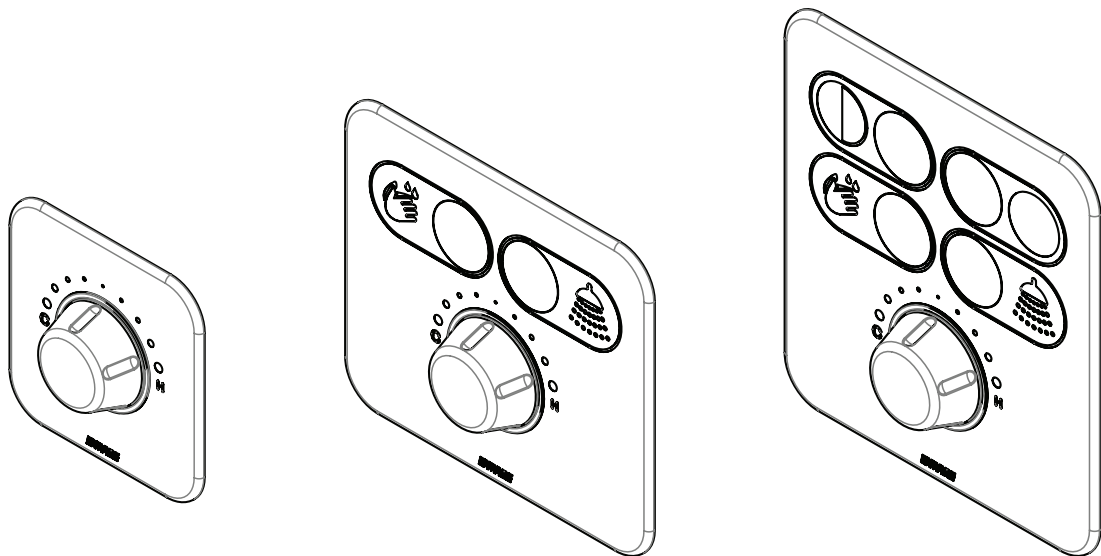

Piezo Button Activation

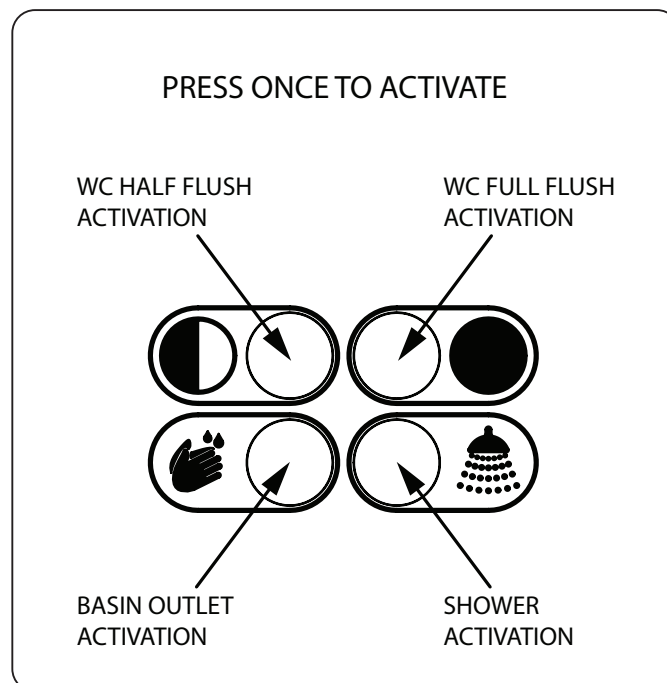

IMAGE 03

Lightly press the piezo button once to activate. SEE IMAGE 03

Temperature Control Wheel and Activation Button (TLI)

Push the wheel button once to activate.*

Turn the wheel to adjust outlet temperature.

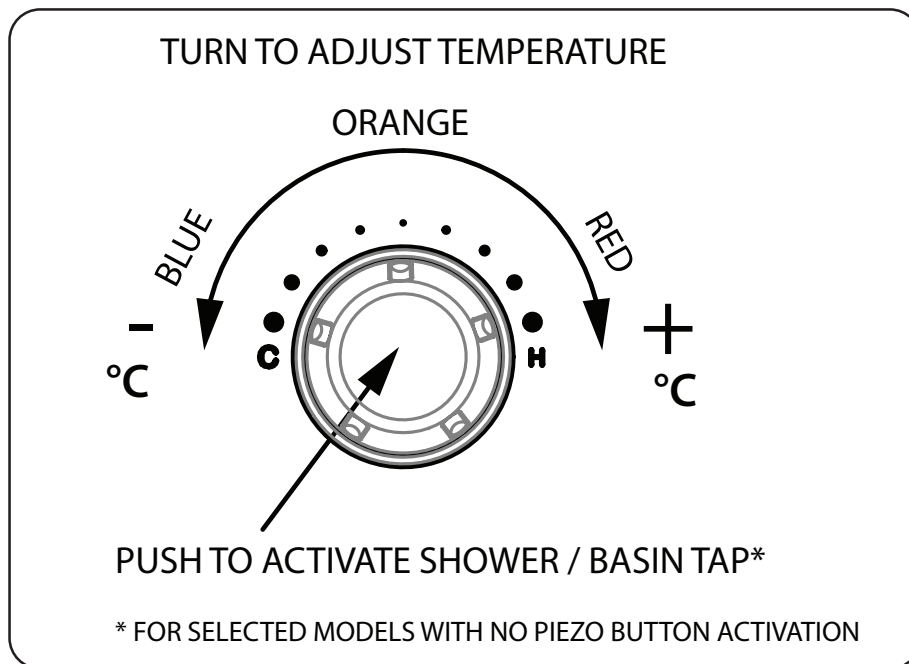

IMAGE 04

The temperature control wheel activation button (TLI) adjusts the temperature of water delivered to shower or basin, and is also a push activation button for shower or basin (depending on the configuration).

The lights in the TLI are used to provide feedback to the user on the current operating state.

When activated the TLI colour will change from blue to orange to red as the temperature set point is adjusted from cold to warm to hot.

TLI Wheel Light Indicators:

- Time Pulse: A number of pulses proportional to the number of minutes the shower has been running will take place periodically. The time between each set of pulses is configurable.
- Eco Pulse: The TLI will pulse green, orange or red depending on how long the shower has been running. The time between each set of pulses is configurable.
- End Flash: The TLI will flash in the last few seconds of the shower.
- 30 Second Warning Flash: The TLI will flash a few times when there is 30s remaining. Disabled if Time Pulse or Eco Pulse are enabled.
- Water Pulse: The water will turn off for 1s then back on when it reaches the pre-set time remainder time before the shower turns off automatically.
- When Disabled: if the user attempts to use a disabled interface it will flash pink 4 times on all TLI control wheels.

commissioning - eTMV

Upon completion of the installation, the valve should be tested and commissioned as per the procedure outlined below or as specified by the local authority.

A calibrated digital thermometer having rapid response time with maximum temperature hold will be required to measure the outlet mixed temperature of the valve. (Enware Code ATMS1200 - Aquablend Test Kit)

1. Check the Outlet Temperature

1. Open the cold supply line to eTMV, then open the hot supply line, ensuring there are no leaks.
2. Activate and open the outlet that is serviced by the shortest length of pipework between the mixing valve and outlet fixture. To do this, press the piezo button or Temperature Control Wheel on the Fascia Control Plate to activate shower or basin tap. (The default maximum run time per activation is 2 minutes for basin and 45 minutes for shower.)
3. Turn the Temperature Control Wheel clockwise to the highest warm water temperature setting.
4. Allow the mixed outlet to flow for at least 60 seconds to allow the temperature to stabilize, then take a temperature reading at the outlet with a digital thermometer. The flow rate should be at least 2L/min. The flow rate can be checked with the aid of a known size container and a stopwatch.
5. Activate the other outlet (if applicable) while the first one is running. Check that the outlet temperature is stable over the full range of flow rates, and that the temperature and flow rate is adequate for the application.

2. Shut Down Test

Now that the temperature has been checked, it is necessary to perform a shut down test.

1. Turn on the outlet and turn the Temperature Control Wheel clockwise to the highest warm water temperature setting. Allow the mixed water temperature to stabilise and note the outlet temperature.
2. While holding a digital thermometer in the outlet flow, quickly isolate the cold water supply to the valve by shutting the cold water inlet isolation valve. (SEE IMAGE 05)
The outlet flow should quickly cease flowing. The flow should be less than 0.1L/min following the isolation. Monitor the maximum outlet flow temperature, and record this on the Commissioning Report. The temperature should not exceed that allowed by the applicable standard or code of practice for each state.

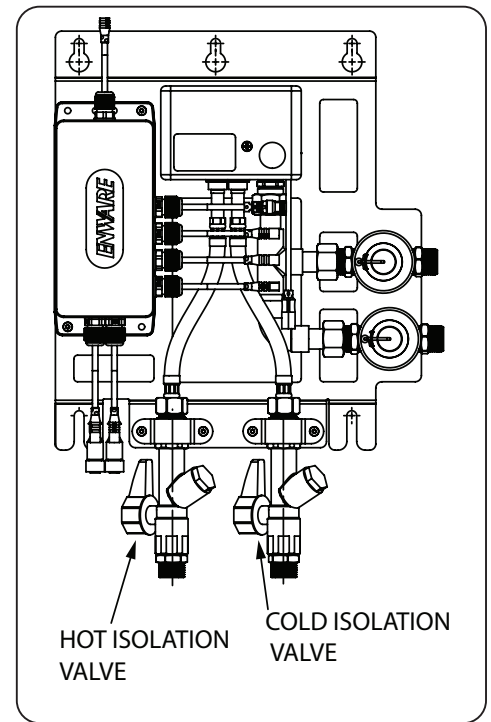

IMAGE 05

3. Restore the cold water supply to the valve. After the mixed water temperature has stabilised, note the outlet temperature again, ensuring the outlet temperature has re-established.
4. Repeat the above test, except this time quickly isolate the hot water supply to the valve by shutting the hot water inlet isolation valve. The outlet flow should quickly slow to a trickle. The trickle should be less than 0.1L/min following the isolation.
5. Restore the hot water supply to the valve. After the mixed water temperature has stabilised, measure and record the outlet temperature, ensuring the outlet temperature has re-established.
6. Turn off the outlets.

Ensure that all details of the Commissioning Report are completed and signed by the relevant signatories, and a copy is kept with the installer and owner of the premises.

The valve is now commissioned and it can be used within the technical limits of operation.

Stagnation Management

Once installed and commissioned the Custodian® Smart Board can operate as an independent device. The operation and control of the fixtures will be determined by the firmware in the eTMV Control Hub.

Stagnation Management allows for the automatic flushing of pipes, especially during commissioning phase or for rooms with an extended vacancy.

Stagnation Management is enabled by default (for Custodian® devices only) and eTMV Control Hub will periodically flush every 72 hours each fixture that has not had enough use, unless Stagnation Management is manually disabled or the firmware is changed. This can be achieved via the software operating on the central control PC via the main Backbone Network Cable, or by a standalone laptop connected directly to the Custodian® eTMV Control Hub.

Manager Activation

Stagnation Management can be enabled or disabled using the Smart Flow Software, or manually disabled by unscrewing the lid and pressing the blue button quickly 3 times. (To turn back on manually, press 6 times.)

Data Logging

Temperature and flow is recorded.

Sequence

If Stagnation Management is enabled, the following sequence will occur at a random time (approximately every 72 hours since last use, to prevent all hubs running simultaneously):

1. T=0m 00s: TLIs start flashing orange, wait 10 seconds
2. T=0m 10s: Shower runs at 40°C for 30 seconds
3. T=0m 40s: Shower stops, wait 3 seconds
4. T=0m 43s: Shower runs at 15°C for 10 seconds
5. T=0m 53s: Shower stops, wait 3 seconds
6. T=0m 56s: Basin runs at 40°C for 30 seconds
7. T=1m 26s: Basin stops, wait 3 seconds
8. T=1m 29s: Basin runs at 15°C for 10 seconds
9. T=1m 39s: Basin stops, wait 3 seconds
10. T=1m 42s: Toilet runs for 3 seconds
11. T=1m 45s: Toilet stops, TLIs return to flashing white

maintenance and servicing - eTMV

The eTMV is a compact Thermostatic Mixing Valve that uses modern self-controlling multiprocessor technology to monitor and control the temperature and flow, by means of ceramic discs and electromechanical drives.

eTMV does not have a thermostatic wax element or dynamic O-rings that are typically used in traditional thermostatic mixing valves. Instead, ceramic discs are controlled by electromechanical drives, and eTMV has no parts to service or replace during regular servicing.

The eTMV is constantly monitored for real-time performance by the Enware Smartflow TMV monitoring system.

The eTMV will only require minimal preventative maintenance work to ensure it operates at its optimum level of performance. The valve should be commissioned, and serviced annually, unless the installed conditions dictate more frequent servicing is necessary.

annual maintenance procedure

Every 12 months eTMV should be inspected and tested. The valve and surrounding area should be inspected for leaks or water damage and action taken if required. Ensure a clean dry work area is available.

Servicing of eTMV is in line with AS4032.3.

Cleaning the Strainers

Firstly isolate the hot and cold supplies to the mixing valve by closing the inlet isolation valves. With a suitable spanner remove strainer cap on the inlet fitting then remove mesh strainer.

Clean strainers with a suitable descaling solvent (such as CLR) diluted with water. Check for physical damage and thoroughly rinse with clean water. Strainers can then be re-installed into the ball valve and strainer cap replaced and tightened to a maximum torque of 15Nm into the inlet ball valve bodies.

Non-Return Valve Operation

To check Non-Return Valve on the HOT inlet side, carry out the following steps:

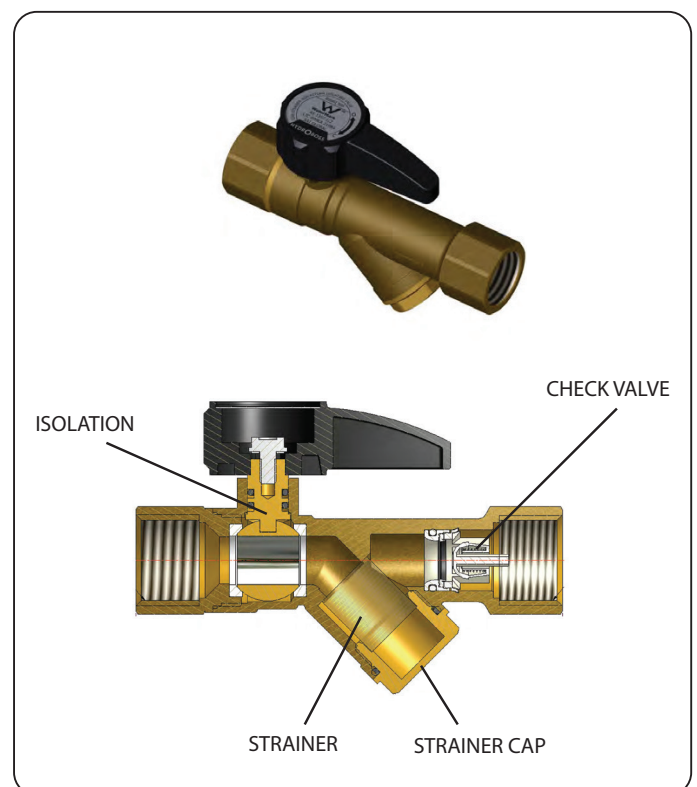

IMAGE 06

-
1. Turn OFF the isolation valve on the HOT inlet only (COLD inlet must be open).
 2. Unscrew and remove Strainer Cap on the HOT side. SEE IMAGE 06
After releasing water pressure initially, observe any water leaking through the strainer.
 3. If water continues leaking through this may indicate a fouled or faulty Non-Return Valve. If this is the case, inspect the non-return valve for damage or any debris. Clean or replace the combination ball valve if necessary.
If water does not leak through, this indicates the check valve is working correctly.
 4. Re-install Strainer Cap.
 5. Turn back ON the isolation tap on the HOT inlet.
 6. To check Non-Return Valve on the COLD inlet side, repeat the above steps using the COLD inlet side.

Check that the strainer caps are tight, and that there is no evidence of water leakage.

Recommissioning and Shut Down Test

The valve must then be recommissioned as per instructions on page 12, including temperature adjustment and shut down test.

If the valve fails to shut down or fails to maintain its set temperature, refer to Troubleshooting on page 19.

5-year maintenance

The eTMV has no mechanical or electronic actuation component to service or replace at regular servicing, and there are no parts to service or replace at 12-month or 5-year intervals as described in the Australian Standard AS4032.3 Section B 4.2 and Section 2.7.1.

No replacement of thermostat or o-rings is required as the eTMV does not have any.

The 5-year maintenance will simply be an annual service. Refer to annual maintenance procedure on page 15.

cleaning

Enware products should be cleaned with a soft damp cloth using only mild liquid detergent or soap and water. Do not use cleaning agents containing a corrosive acid, scouring agent or solvent chemicals. Do not use cream cleaners, as they are abrasive. Use of unsuitable cleaning agents may damage the surface. Any damage caused in this way will not be covered by warranty.

thermal flush procedure

Thermal Flush feature in eTMV allows the facility's maintenance team or licensed service contactors to perform a controlled thermal flush to the eTMV and warm water plumbing system. (Note: The thermal flush procedure is optional and does not form part of commissioning and service requirements set out in AS4032.3.)

Before commencing the thermal flush, a site-specific procedure must be implemented to control the risk of scalding. Hot water will run directly to the outlets fed by the Electronic Thermostatic Mixing Valve, and precautions shall be taken to prevent the chance of injury.



Note: full temperature hot water will flow from the tapware. Care must be taken to prevent scalding.

Manager Activation

It can be enabled or disabled using the Smart Flow Software, or by unscrewing the lid of Control Hub and pressing the blue button quickly 15 times.

Data Logging

Temperature and flow is recorded.

Thermal Flush Sequence

1. When Thermal Flush is enabled through Smart Flow Software, the temperature control wheels (TLI) will start flashing red and white. Note this will automatically disable after 3 minutes if left in this state.
2. Within 3 minutes, press a TLI button for 10 seconds until it begins rapidly flashing red. (If there are multiple TLI's, only one of them needs to be pressed.)
3. Within 5 seconds, press the TLI button once. A slow, red flashing will start.
4. After 3 seconds, the shower and basin solenoids will open simultaneously and the eTMV will run for 3 seconds at 15°C.
5. Next, eTMV will allow full hot water to pass through the eTMV and solenoids for 1 minute to allow the temperature to stabilise.
6. It will then run for 5 minutes at 70°C or 10 minutes at 60-70°C.
7. The eTMV will deliver cold water for 30 seconds. The TLI's will pulse blue during this period.
8. The water stops and the TLIs will flash white 3 times if the thermal flush was a success. If there is any issue with the system during this process (e.g. it didn't achieve the minimum 60°C temperature) then the TLI will flash orange to show there was an error that needs investigating.
9. The thermal flush process can be stopped at any time by pressing a TLI button, which will send the system back to step 1.

access to components

Replacing eTMV

1. Unscrew cover of eTMV.
SEE IMAGE 07
2. Loosen 2 screws holding eTMV to board and keep at hand.
SEE IMAGE 09
3. Unplug eTMV cable. When unplugging cables, hold the connectors, do not pull on the cables to unplug.
4. Unscrew 2 fixing screws holding the inlet and outlet adaptors.
SEE IMAGE 09 & 10
5. Once eTMV is loose, pull up the eTMV to release it from water connections.
SEE IMAGE 10

To connect new eTMV to water connections, align inlets and slowly but firmly push eTMV into position. SEE IMAGE 10

Take cover off. Fix eTMV to board with the 2 screws that was taken in step 2.

Fit 2 screws taken in step 3 to lock the water inlet adaptors in place. Re-fit cover.

When reconnecting cables, align the white marking on the connectors to ensure correct orientation.

Commission eTMV, by following the commissioning procedure on page 12.

Replacing eTMV Control Hub

1. Unscrew 2 screws holding the Control Hub. SEE IMAGE 11
2. Unplug cables. When unplugging cables, hold the connectors and do not pull on the cables to avoid damage.
3. Replace eTMV Control Hub with a new one.

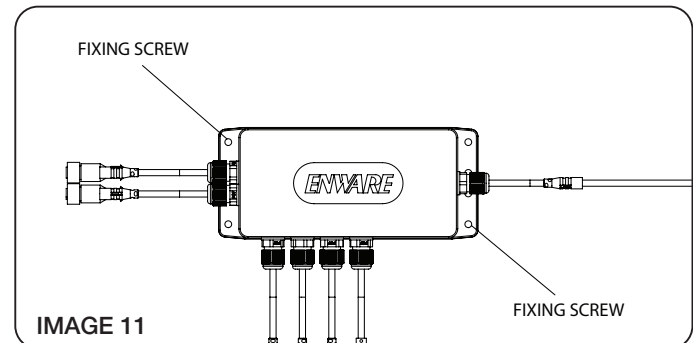
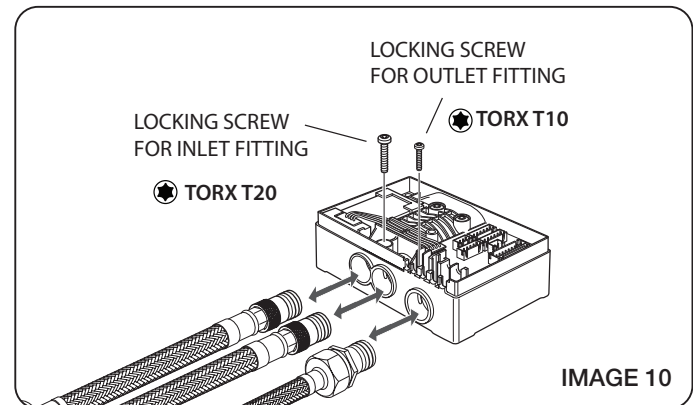
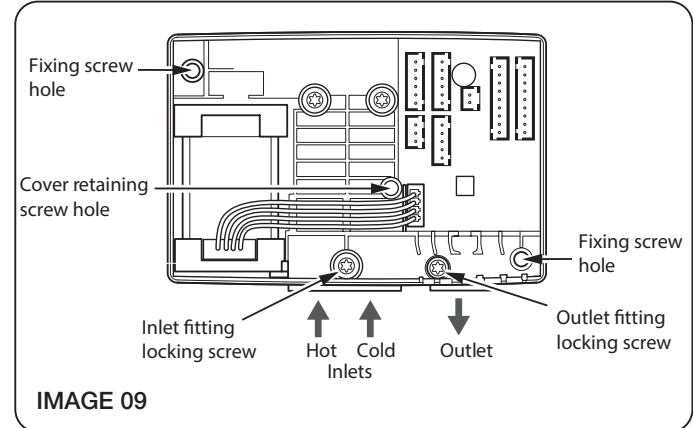
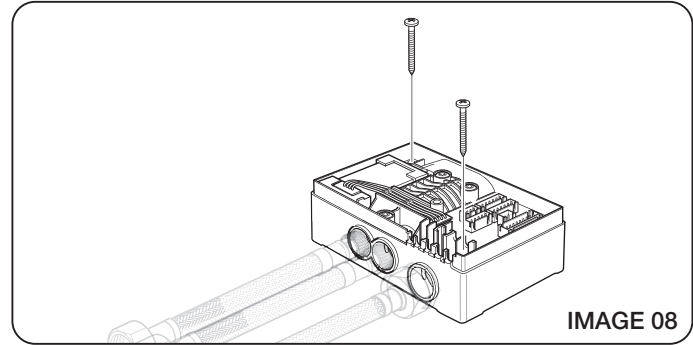
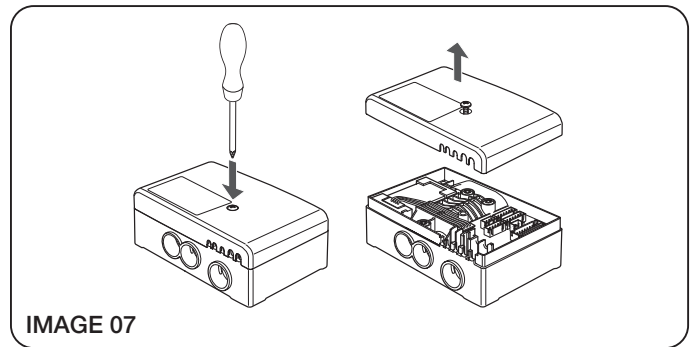

troubleshooting

FAULT / SYMPTOM	CAUSE	RECTIFICATION
1. Desired mix temperature can't be obtained / is difficult to set	<ul style="list-style-type: none"> * Supply water pressure is too high * Pressure differential between hot and cold supplies are too high * Flow rate is too high or too low * Debris in line * Temperature setting is too high / too low 	<ul style="list-style-type: none"> * Ensure water supplies are within limits of the valve as outlined in Technical Table on page 4 * Check for debris in line and clean * Check system temperature setting
2. Mixed water temperature too hot or cold		
3. Flow rate reduced or fluctuating		
4. eTMV is noisy		
5. The valve will not shut down	<ul style="list-style-type: none"> * Supply water temperature too high or too low * Ceramic disc in eTMV has failed * Debris in line 	<ul style="list-style-type: none"> * See Rectification 1 * Replace eTMV
6. Hot water flows into cold water system or vice versa	<ul style="list-style-type: none"> * Check valve has failed * Debris fouling check valve 	Dismantle and clean / replace combination inlet valve
7. Water leaks from outlet / Water drips and does not shut off	<ul style="list-style-type: none"> * Debris in line * Supply water pressure too high * Solenoid has failed 	<ul style="list-style-type: none"> * See Rectification 1 * Check solenoid for debris and clean. Replace solenoid if required
8. Water is not flowing / 9. Poor water flow	<ul style="list-style-type: none"> * Aerator/ line is blocked by debris * Water or power turned off * eTMV has shut down 	<ul style="list-style-type: none"> * Dismantle aerator or flow control and clean * Turn on power / water * See Rectification 1

For further assistance, call Enware on 1300 369 273.

spare parts

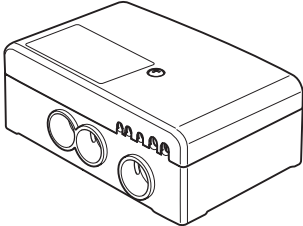
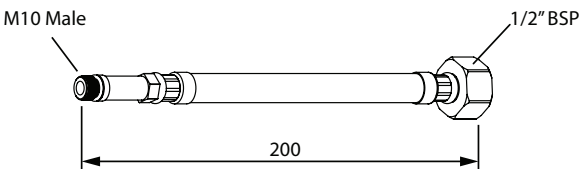
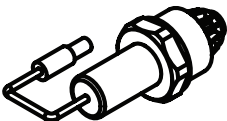
Name		Part Code
Electronic TMV		WMS-ETMV01
Smart Board Hose - 8mm x 1/2" BSP (each)		WMSSB-HOSE
Solenoid - Basin / Shower (each)		WMS207

Commissioning / Service Report for Thermostatic Mixing Valve

Use a separate form for each valve.

The original report is to be retained on site for a minimum of 7 years.

Copies of the report shall be : provided to the owner/ occupier or the person responsible ; retained by the tester ; and where required, forwarded to the relevant authority.

The test method is in accordance with AS4032.3 Appendix B.

Name of Establishment	(Name)	Owner / Occupier	(Name)
Street Address			
Contact Name	(Name)	Phone	
Date of Test		Work Order No.	

Valve ID No.		Model No.	
Make of TMV		Size	

Valve location / Building	
Area Serviced by Valve	

Number of Outlets Served	Basin	Shower	Bath
--------------------------	-------	--------	------

Valve installed to requirements of		
1. The local water supply authority	2. The valve manufacturer / supplier requirements	3. The Australian Standards for Plumbing and Drainage
<input type="checkbox"/> YES <input type="checkbox"/> NO	<input type="checkbox"/> YES <input type="checkbox"/> NO	<input type="checkbox"/> YES <input type="checkbox"/> NO
If NO, give details and action taken:		

Valve functioning in accordance with the application requirements:	<input type="checkbox"/> YES	<input type="checkbox"/> NO
If NO, give details and action taken:		

Inlet Temperature and Pressure Tests

Inlet Hot Water	Pressure	kPa	Inlet Cold Water	Pressure	kPa
	Temp	°C		Temp	°C
Cold Supply via: mains / tank / pump			Pressure Reduction Valve Fitted: <input type="checkbox"/> YES <input type="checkbox"/> NO		
Hot Water Unit:			PRV : <input type="checkbox"/> YES <input type="checkbox"/> NO		

Temperature of Mixed Warm Water at Outlet (measured at the nearest outlet to the valve)

Set Temperature:	°C	Temperature Range	<input type="checkbox"/> Neonatal and children 38 - 40°C <input type="checkbox"/> Adult 40.5 - 43.5°C <input type="checkbox"/> 45°C max. <input type="checkbox"/> 50°C max.
At maximum flow	°C	At minimum flow	°C

Thermal Shut-Off Tests

Hot Water Isolation Test:	<input type="checkbox"/> PASS	<input type="checkbox"/> FAIL
Cold Water Isolation Test:	<input type="checkbox"/> PASS	<input type="checkbox"/> FAIL

Details of Test and Maintenance:

Type of work carried out:	<input type="checkbox"/> Commissioning	<input type="checkbox"/> Service	<input type="checkbox"/> 5-Year Service
Strainers	<input type="checkbox"/> Cleaned	<input type="checkbox"/> Replaced	
Non-Return Valves	<input type="checkbox"/> Checked	<input type="checkbox"/> Replaced	
O-rings and Seals	<input type="checkbox"/> Not Applicable	<input type="checkbox"/> Checked	<input type="checkbox"/> Replaced (max. 5-year intervals)
Thermostatic Element	<input type="checkbox"/> Not Applicable	<input type="checkbox"/> Checked	<input type="checkbox"/> Replaced (max. 5-year intervals)
Valve Replaced	<input type="checkbox"/> Yes	<input type="checkbox"/> No	
Other Items Replaced:			

Date of Installation	
Valve installed by	(Name)
Date of Previous Service	
Previous Service by	(Name)
Date of This Service / Commissioning	
Date of Next Service Due	

It is hereby certified that all the commissioning work has been carried out by the undersigned in accordance with local plumbing requirements for Thermostatic Mixing Valves

Contractor Business Name	(Name)	
Contractor Name (print)	(Name)	Contractor Lic / Cert No.
Phone No		
Name of Authorised Tester (Licensed Plumber)	(Name)	
Signature of Authorised Tester (Licensed Plumber)	(Signature)	Date
Owner / Occupier Signature	(Signature)	Date

Enware Australia (“we” or “us”) warrants that this product (also referred to as “our goods”) will be free from all defects in materials and workmanship for 5 years* from the date of purchase. Our liability under this warranty is limited at our option to the repair or replacement of the defective product or part, the cost of repair of the defective product or part or the supply of an equivalent product or part, in each case if we are satisfied the loss or damage was due to a defect in the materials or workmanship of the product or part. All products must be installed in accordance with the manufacturer’s instructions, the PCA, and AS/NZS3500 including any other applicable regulatory requirements.

making a claim

To make a claim under this warranty you must notify us in writing within 7 days of any alleged defect in the product coming to your attention and provide us with proof of your purchase of the product and completed the Online Product Service and Warranty Form available on website www.enware.com.au/product-service-enquiry.

All notifications and accompanying forms must be sent to us marked for the attention of the Enware Australia, 9 Endeavour Road, Caringbah NSW 2229. We can also be contacted by telephone (1300 369 273) or by email (info@enware.com.au).

Your costs in making a claim under this warranty, including all freight, collection and delivery costs, are to be borne and paid by you. We also reserve the right at our cost to inspect any alleged defect in the product wherever it is located or installed or on our premises.

**5 Years Conditional Warranty: 2 years parts and labour on the complete assembly; an additional 3 years, parts supply only, on the eTMV excluding inlet fitting assemblies*

exceptions

This warranty does not apply in respect of any damage or loss due to or arising from:

- a) Failure by you or any other person to follow any instructions for use (including instructions and directions relating to the handling, storage, installation, fitting, connection, adjustment or repair of the product) published or provided by us;
- b) Failure by you or any other person responsible for the fitting, installation or other work on the product to follow or conform to applicable laws, standards and codes (including the AS/NZ 3500 set of Standards, all applicable State and Territory Plumbing Codes, the Plumbing Code of Australia and directions and requirements of local and other statutory authorities); or
- c) Any act or circumstance beyond our control including faulty installation or connection, accident, abnormal use, acts of God, damage to buildings, other structures or infrastructure and loss or damage during product transit or transportation.

other conditions

Except as provided or referred to in this document, we accept no other or further liability for any damages or loss (including indirect, consequential or economic loss) and whether arising in contract, tort or otherwise. Any benefits available to you under this warranty are in addition to any non-excludable rights or remedies you may have under applicable legislation, including as a “consumer” under the Australian Consumer Law. To that extent you need to be aware that: Our goods come with guarantees that cannot be excluded under the Australian Consumer Law. You are entitled to a replacement or refund for a major failure and for compensation for any other reasonably foreseeable loss or damage. You are also entitled to have the goods repaired or replaced if the goods fail to be of acceptable quality and the failure does not amount to a major failure.



ADDRESS: 9 Endeavour Rd Caringbah NSW 2229 Australia
POSTAL ADDRESS: P.O. Box 2545, Taren Point NSW 2229 Australia
PHONE: +61 2 8556 4000
1300 369 273 (AUS) WWW.ENWARE.COM.AU INFO@ENWARE.COM.AU

