

# Smart Flow Water Monitoring System

## SFM Cabling Installation Scope

Document Date: 2026-03-05



# Table of Contents

Table of Contents.....	2
Scope overview.....	3
Enware Scope.....	3
Cabling Contractor Scope.....	3
Plumber Scope.....	3
Builder Scope.....	3
Contractor Responsibility Assignments.....	4
System Architecture.....	5
Hospital IT Network.....	6
TMV Monitoring Plans.....	7
TMV & Fixture Monitoring Plans.....	8
RS485 Backbone Cabling.....	9
Backbone Cabling Details.....	9
Backbone Cabinet Layout.....	10
Backbone Connector.....	11
Backbone Testing.....	12
Backbone Labeling.....	13
Hub Cabling (Hub to TMV / Fixture).....	14
Hub Cabling Details.....	14
Hub Cabling Cabinet Layout.....	15
Hub Cabling Testing.....	16
Hub Cabling Labeling.....	17

## Scope overview

The scope for the Smart Flow Water Monitoring System is as follows:

### Enware Scope

- **SFM Backbone Dual Connectors:** Supply of backbone connectors
- **HUB Cabinets:** Supply of hub cabinets
- **Initial System Plans:** Supply of plans for all cable runs and locations
- **As Built Plans:** Supply of final As-Built drawings based on markup plans
- **SFM LAN Interfaces:** Supply, configuration, installation and testing
- **SFM TFP HUBs:** Supply, addressing, installation and testing
- **TMV & Fixture Sensors:** Supply, installation and testing
- **Smart Flow Backbone Testing:** Confirming that all devices are connected on the RS485 network

### Cabling Contractor Scope

- **RS485 Backbone cables:** Supply of CAT6 cable, installation, termination and testing
  - If SFM9000C is ordered Enware will terminate, test and label the cable that is supplied and roughed in by others
- **Hub to TMV & Fixture Cables:** Supply of CAT6 cable and RJ45 plugs, installation, termination, testing and labelling.
  - If SFM9000C is ordered Enware will terminate, test and label the cable that is supplied and roughed in by others
- **Conduit:** Supply and installation of conduit, we recommend 20mm from the TMV / Fixture to the ceiling and 40mm from the hub cabinet to the ceiling.
- **Testing:** Supply of test results for all cabling
- **Markup Plans:** Markup of any changes to initial system plans

### Plumber Scope

- **Hub Cabinets:** Installation of hub cabinets in the walls including lids at a preferred height of 1.5m
- **TMV & Fixture Schedule:** A spreadsheet linking the hub ports to the TMVs and fixtures and providing asset location information and information on the rooms serviced
- **Communication of changes:** regarding added or deleted TMVs or fixtures during the build

### Builder Scope

- **Co-ordination:** Co-ordination of services
  - **BMS Integration:** Co-ordination of BMS integration requirements
-

- **IP addresses:** Provision of IP address allocations and rack allocations
- **Room Naming:** Provision of Hospital wayfinding room naming information
- **Training:** Co-ordination of client training

## Contractor Responsibility Assignments

Component	Installed location	Supplied by	Installed by	Timing	Notes
<b>System Engineering Design</b>	n/a	Enware	n/a	Commencement of Project	Design to be supplied at commencement and modified and updated as required
<b>SFM hub Cabinets</b>	In corridor walls as shown on plans	Enware	<b>Plumber</b>	At plumbing rough in stage	Hub cabinets installed at the same time as TMVs
<b>HUB to TMV &amp; Fixture Cable Rough In (CAT6)</b>	Walls and ceilings between hubs and TMVs / fixtures	Cabling Contractor	<b>Cabling Contractor</b>	At plumbing rough in stage	Cabling contractor to supply CAT6 cable and rough in.
<b>HUB to TMV / fixture cable terminations &amp; test (RJ45)</b>	Walls	Cabling Contractor	<b>Cabling Contractor</b>	After Cable Rough in	Cabling contractor to supply RJ45 plug, terminate, test, label and markup plans. (unless SFM9000C is ordered)
<b>Backbone Cable Rough In (CAT6)</b>	Walls and ceilings between hubs	Cabling Contractor	<b>Cabling Contractor</b>	Prior to plastering	Cabling contractor to supply CAT6 cable and rough in.
<b>Backbone Cable terminations &amp; test (RJ45)</b>	Walls	Enware	<b>Cabling Contractor</b>	Prior to plastering	Enware to supply backbone connectors Cabling contractor to terminate, test, label and markup plans. (unless SFM9000C is ordered)
<b>Conduit</b>	Walls	Cabling Contractor	<b>Cabling Contractor</b>	At plumbing rough in stage	We recommend: TMV / fixture and ceiling: 20mm Hub cabinet to ceiling: 40mm
<b>SFM TFP HUBs</b>	In hub cabinets	Enware	Enware	System commissioning	Not Installed until all plastering and painting is completed
<b>Cable Audit</b>	N/A	Enware	N/A	System commissioning	Enware will audit the backbone and hub to TMV / fixture cabling to ensure it is correct & matches the plans.
<b>LAN Interfaces</b>	Comms Rooms on each level	Enware	Enware	System commissioning	Installed when Comms rooms are completed and active equipment has been installed.
<b>On-Prem Server</b>	Central Comms Room	<b>VM:</b> LHD IT <b>Physical:</b> Enware	LHD IT Enware	System commissioning	
<b>SFM Azure Platform</b>	Cloud	Enware	Enware	System commissioning	Commissioned once: - TMV / fixture schedule is finalised. - IP network details are finalized - On-prem server is commissioned - On-prem server to Azure connection is working

# System Architecture

The Smart Flow System utilizes three cabling network components in the complete system architecture.

These are:

1. **Hospital IT Network** – supplied by others
2. **RS485 Backbone Network** – connects Smart Flow field devices (HUBs) together back to the Comms Room
3. **HUB Cabling** – connects sensors at TMVs and Fixtures back to HUBs

The system design can be replicated without limit over multiple levels and buildings. Each level will contain its own RS485 Network cabled back to a LAN Interface on each Level. Enware will supply Plans showing all HUB locations, the backbone system design, and all connected endpoints for sensors, either TMVs or fixtures.

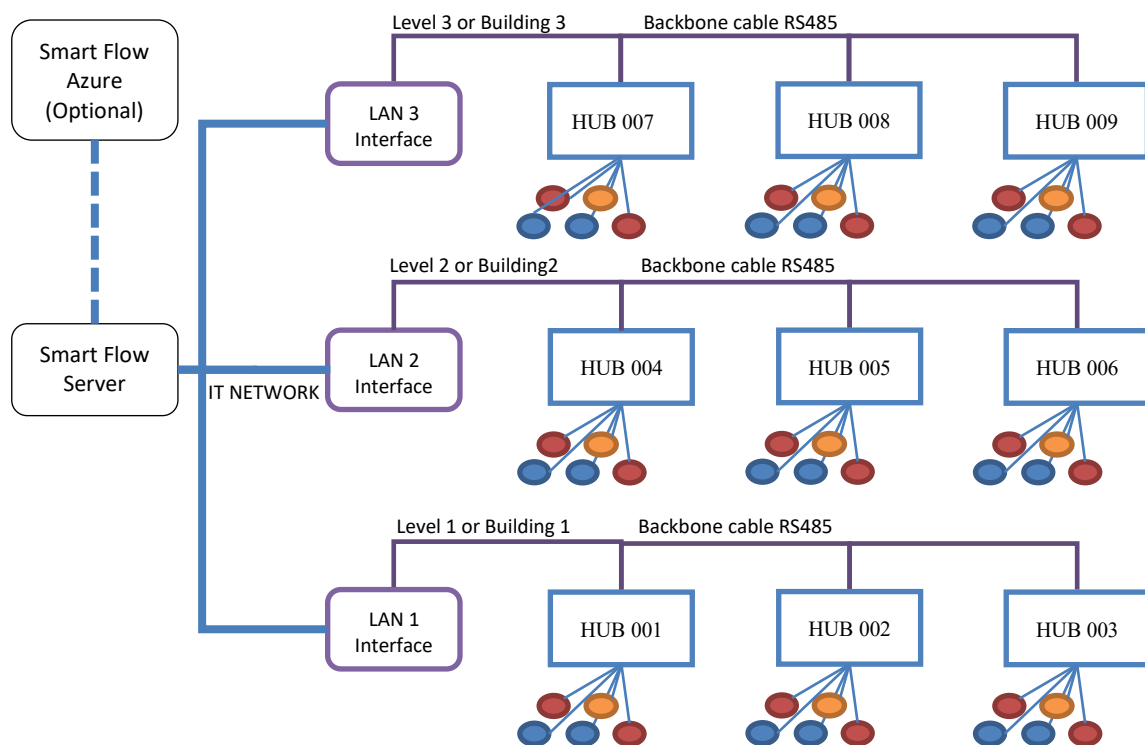

**Note:** The RS485 Backbone Cable and hub to TMV / fixture cabling **are not** part of the structured cabling network. All cable should be installed by a qualified person.

## Hospital IT Network

The hospital IT network is not part of this scope, it is up to others to provide essential networking equipment such as space in the racks, switch ports, IP addresses etc.

The hospital IT network is the Structured Cabling Network and stands separate from Smart Flow System Cabling. The Smart Flow system utilizes the Hospital IT Network to efficiently communicate across the whole Hospital site.

Each floor of each building will typically have a single RS485 backbone between each of the hubs which run back to comms room where the LAN Interface is in the rack. The Smart Flow LAN Interface connects to the hospital IT network via ethernet. The LAN Interfaces are installed in the rack by Enware.

An on-premises server is typically required for each Smart Flow installation, this server may be a physical server provided by Enware (order code SFM6100) or a virtual machine provided by hospital IT. If it is a physical server, it will be installed in the rack by Enware.

The LAN Interfaces communicate with the server via the hospital network, the server will communicate to both the BMS via BACnet IP and the Smart Flow Azure Cloud Service that aggregates multiple Smart Flow installations throughout a local health district or private operator into a single management portal [ssf.smartflow.com.au](https://ssf.smartflow.com.au).

## TMV Monitoring Plans

The example below shows a typical plan that will be supplied to the contractor by Enware. This plan will show the suggested locations of HUB cabinets. As HUB cabinets installed in walls are considered an architectural item, final locations will need to be confirmed by others. Hubs should be installed in the walls in the corridors.

The backbone cable should be run in the route shown, **any changes to backbone routing due to onsite practicalities shall be documented on the site plans and reported back to Enware.**

The hub cabling cable should be run to the hub and hub port shown on the plans, **any changes to hub cabling due to onsite practicalities shall be documented on the site plans and reported back to Enware.**

As can be seen on the plans, TMVs are labeled based on the hub number and port number in the format:

- “TMV YYY-Z” eg “TMV 004-1”
  - YYY is the hub number (address) starting at 001
  - Z is the hub port (sensor port position) starting at 1

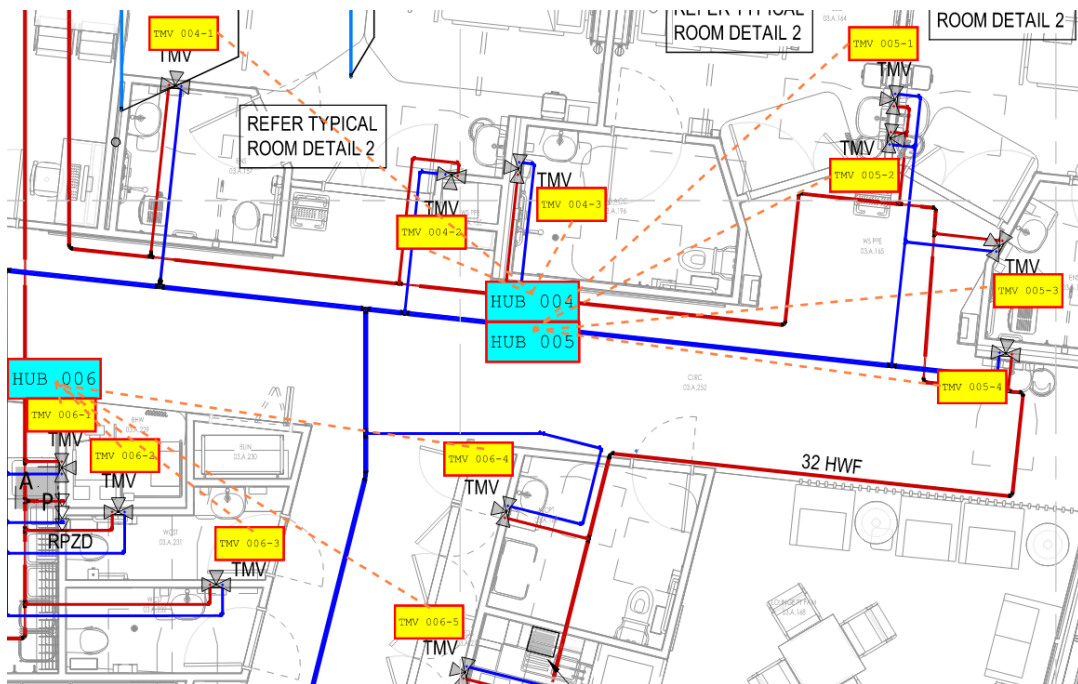

## TMV & Fixture Monitoring Plans

The example below shows a typical plan that will be supplied to the contractor by Enware. This plan will show the suggested locations of HUB cabinets. As HUB cabinets installed in walls are considered an architectural item, final locations will need to be confirmed by others. Hubs should be installed in the walls in the corridors.

The backbone cable should be run in the route shown, **any changes to backbone routing due to onsite practicalities shall be documented on the site plans and reported back to Enware.**

The hub cabling cable should be run to the hub and hub port shown on the plans, **any changes to hub cabling due to onsite practicalities shall be documented on the site plans and reported back to Enware.**

As can be seen on the plans, TMVs and fixtures are labeled based on the hub number at port number in the format:

- “XXX YYY-Z” eg “BSN 001-3”
  - XXX: the asset type eg:
    - TMV: Thermostatic Mixing Valve
    - BSN: Basin
    - SWR: Shower
  - YYY is the hub number (address) starting at 001
  - Z is the hub port (sensor port position) starting at 1

For assets that are virtually monitored the following convention is used:

- “XXX YYY-ZV” eg “BSN 001-1V”
  - XXX: the asset type eg:
    - BSN: Basin
    - SWR: Shower
  - YYY is the hub number (address) starting at 001
  - Z is the hub port (sensor port position) of the upstream TMV

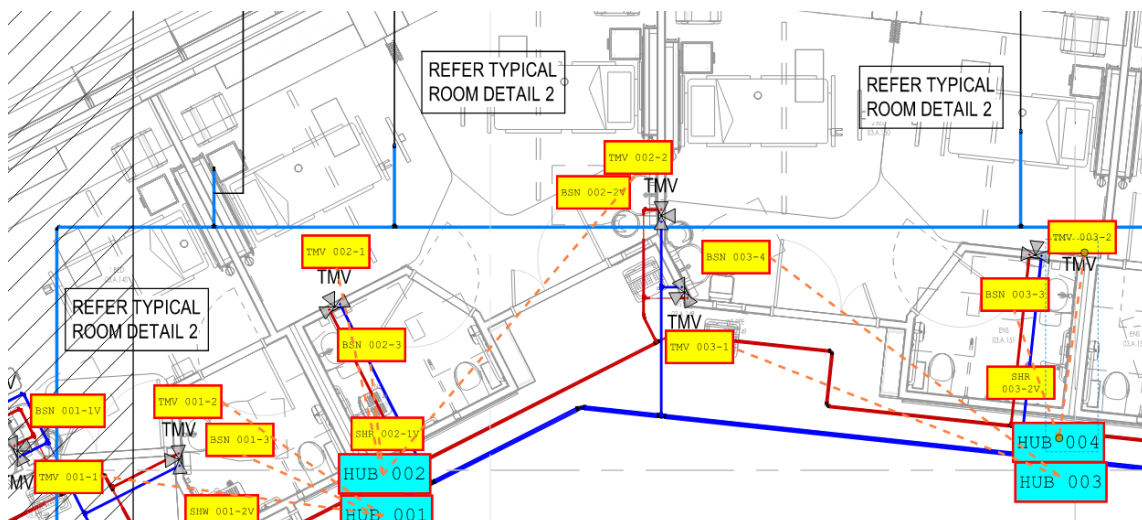

# RS485 Backbone Cabling

## Backbone Cabling Details

- Installed using CAT6 unshielded cable
- 0.5m service loop in the ceiling space above the hub.
- Architecture is daisy chained from hub cabinet to hub cabinet with termination to a SFM backbone dual connector.
- The incoming and outgoing cable are terminated in the backbone connector.
- One backbone connector is located in each hub cabinet.
- Hub cabinets can fit either 1 Hub with up to 5 TMVs/fixtures or 2 hubs to monitor up to 10 TMVs / fixtures as indicated on initial Enware supplied plans.
- The backbone cable must be run so that the HUBs are installed in sequential order.
- We strongly recommend installation of 40mm conduit between the hub cabinet and the ceiling space.
- Each backbone should have a maximum of 25 hubs
- Each building should have separate backbones
- Each level in buildings separate backbones

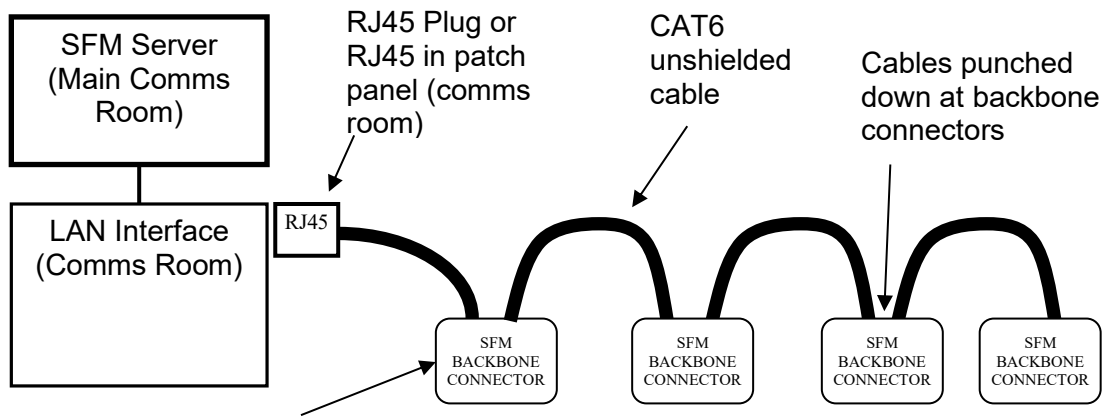

**DESC:** SFM BACKBONE DUAL CONNECTOR SURFACE MOUNT

**MFR:** Enware

**CODE:** SFM-BB-SURFACE

Pin	Colour	Description
1	Green/White	Gnd supply voltage
2	Green	24V supply voltage
3	Orange/White	Gnd supply voltage
4	Blue	RS485 A Comms
5	Blue/White	RS485 B Comms
6	Orange	Gnd supply voltage
7	Brown/White	24V supply voltage
8	Brown	Gnd supply voltage

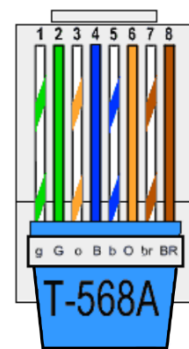

## Backbone Cabinet Layout

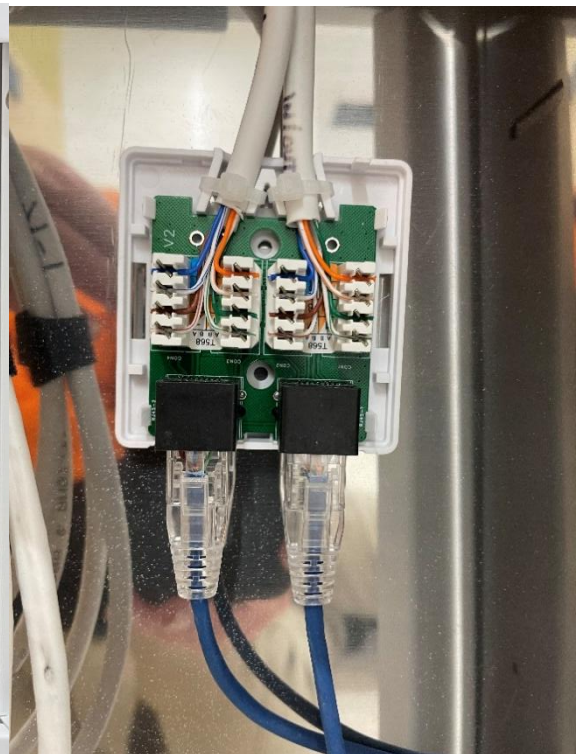
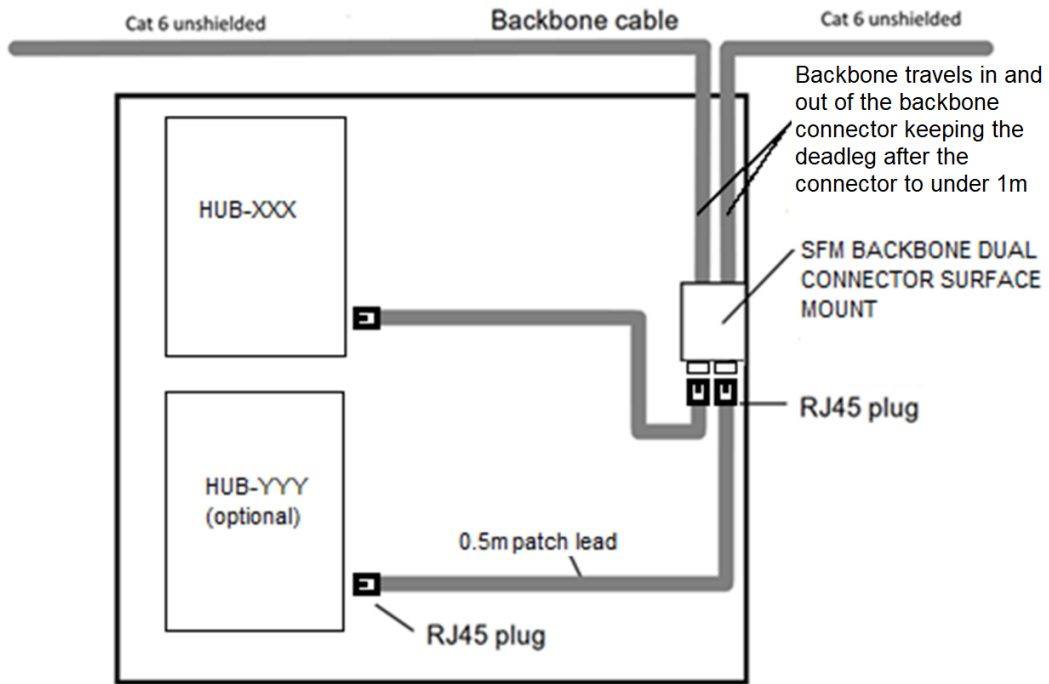

## Backbone Connector

The Backbone connector is designed to simplify the installation of the backbone by removing the need to double punch the incoming and outgoing wires into the same RJ45 keystone connector.

The two sets of punch down connectors and the two RJ45 ports are linked inside the PCB so that a bridging wire between the 2 sides is no longer necessary.

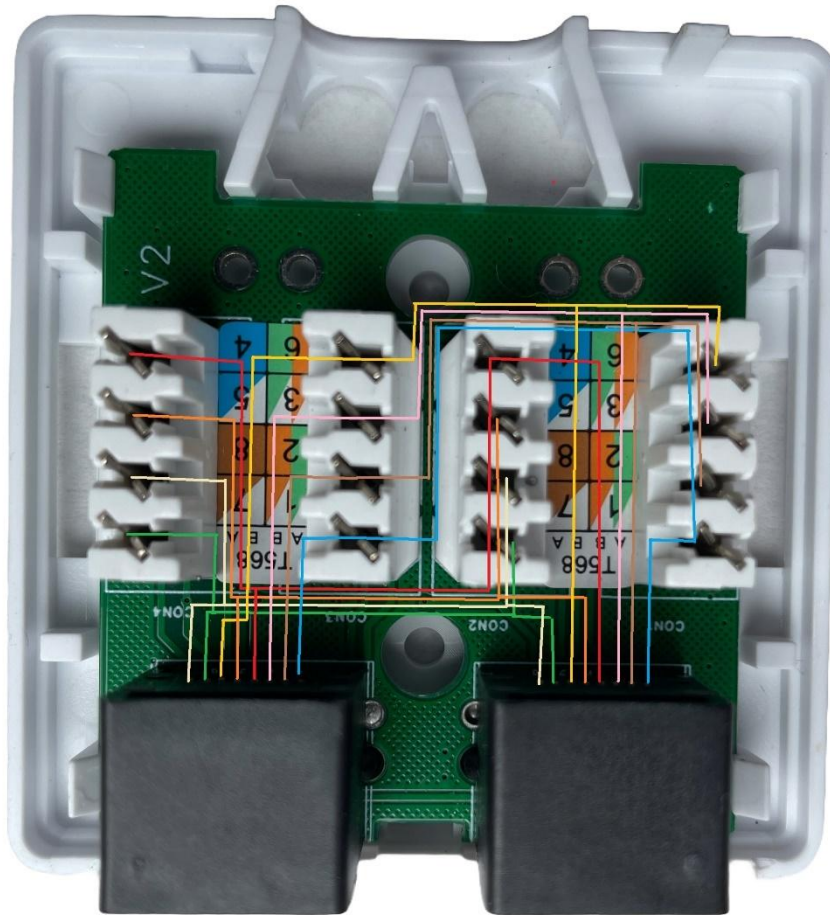

The backbone connector pictured above will be included with every hub cabinet. The code is any are lost is SFM-BB-SURFACE.

## Backbone Testing

Testing of the backbone is essential **prior to hub installation**.

When testing the backbone all smart flow hubs and the LAN interface will need to be disconnected from the backbone prior to testing.

Testing of all individual connections throughout the entire backbone run is required. End-to-end testing is not sufficient.

Start	End	Test Result	Tested By	Test Date	Comment (only if required)
L5 Comms	Hub 001				
L5 Comms	Hub 002				
L5 Comms	Hub 003				
L5 Comms	Hub 004				
L5 Comms	Hub 005				
L5 Comms	Hub 006				
L5 Comms	Hub <last>				

## Backbone Labeling

The backbone cable should be labeled with the hub it is going (or LAN interface) to so that the cables can be easily traced.

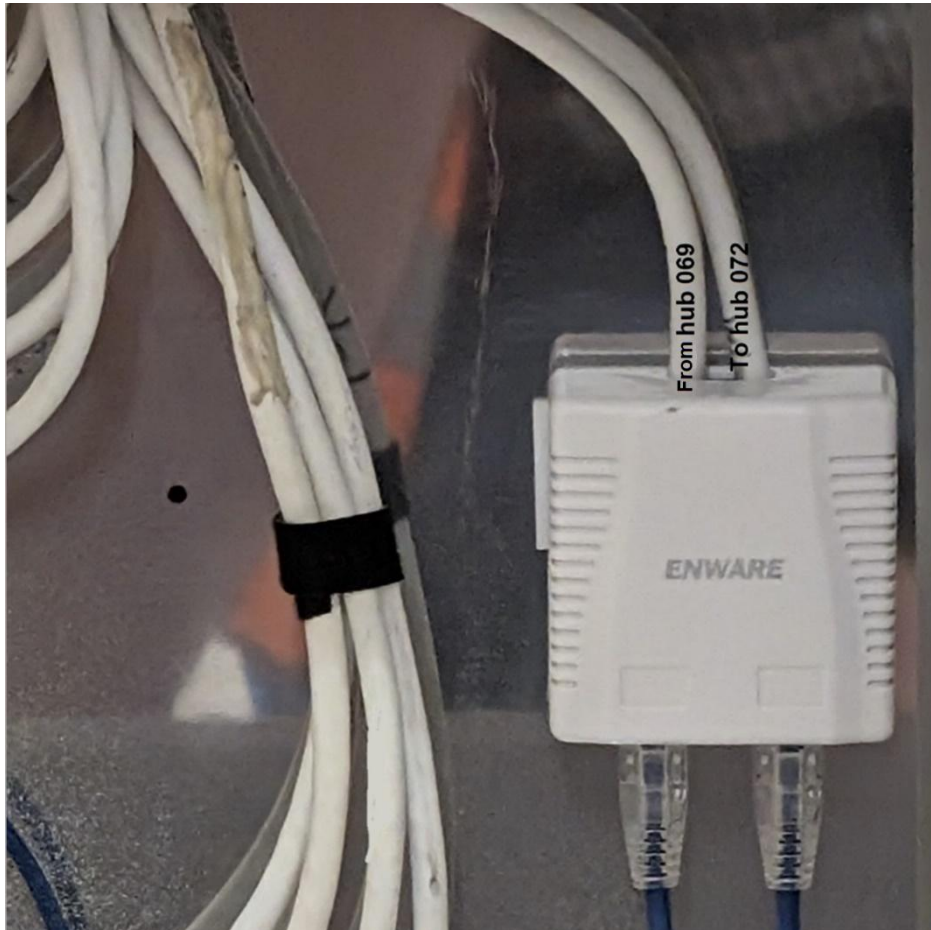

# Hub Cabling (Hub to TMV / Fixture)

## Hub Cabling Details

All HUB to TMV or Fixture cables are as follows:

- Cable – CAT6 Unshielded
- 0.5m service loop in the ceiling space above the hub and TMV / fixture encase additional cable is required
- Terminations – RJ45 plugs both ends
- PIN output – T-568A
- We recommend installation of 20mm conduit between the TMV and the ceiling space
- The maximum length individual cables should be kept below 35m

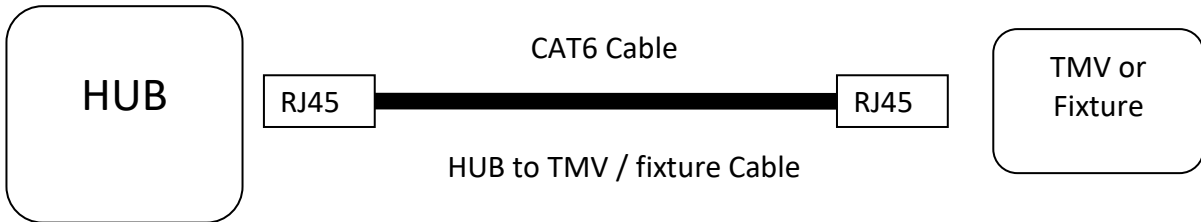

Pin	Colour	Description
1	Green/White	GND supply voltage
2	Green	24V supply voltage
3	Orange/White	Temperature sensor for cold water
4	Blue	Flow sensor for cold water
5	Blue/White	Flow sensor for hot water
6	Orange	Temperature sensor for hot water
7	Brown/White	Flow sensor for warm water
8	Brown	Temperature sensor for warm water

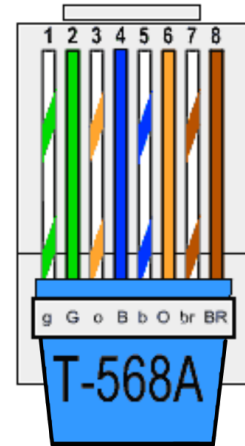

## Hub Cabling Cabinet Layout

Each hub can support up to 5 TMVs / fixtures on ports 1-5 and 2 pressure sensors on port 6.

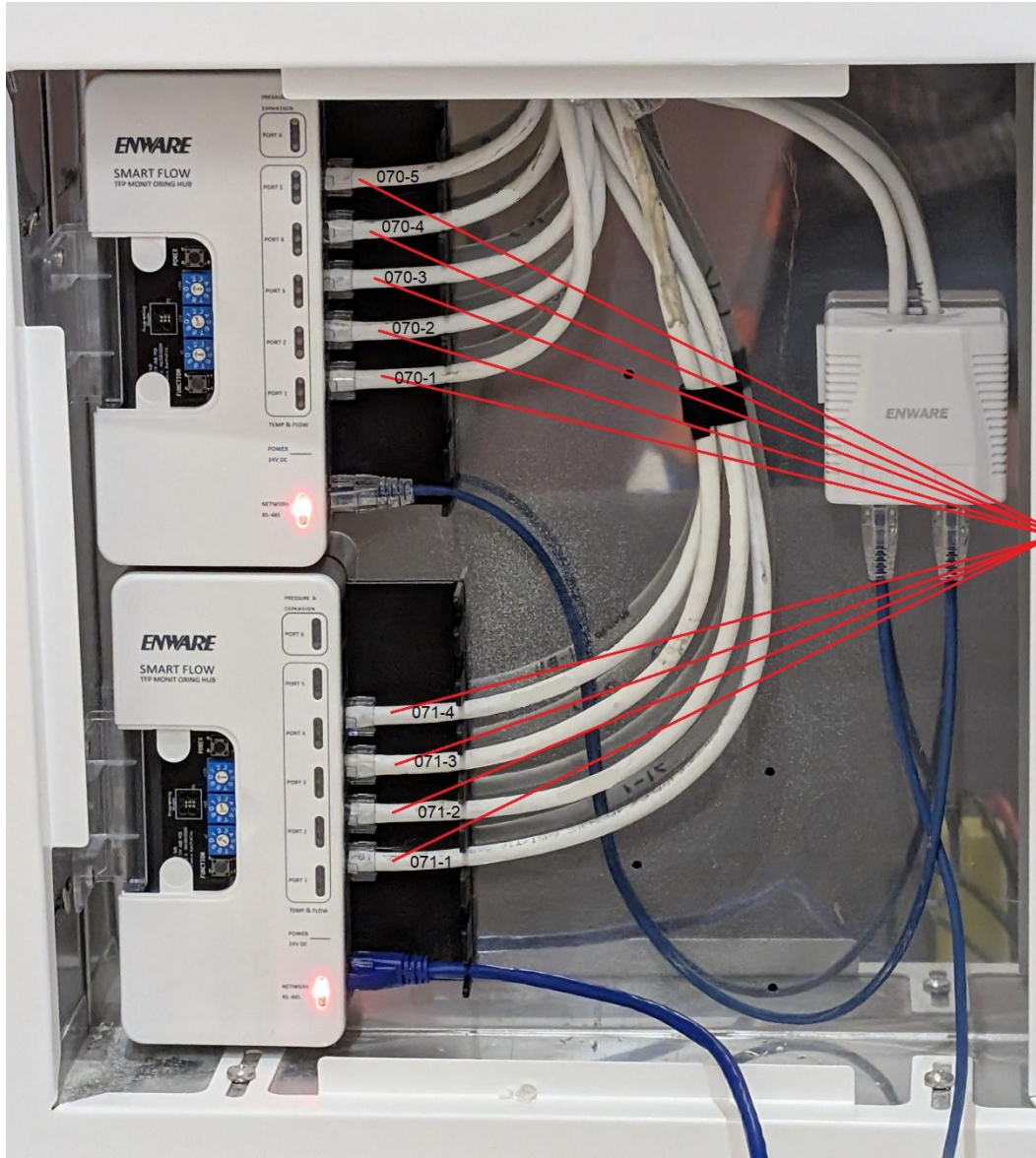

## Hub Cabling Testing

Testing of the hub cabling is also essential to deliver a functioning system. The SFM TFP hub pinout is below, but for testing purposes the cable can be treated as a standard RJ45 cable and tested as such using industry standard tools.

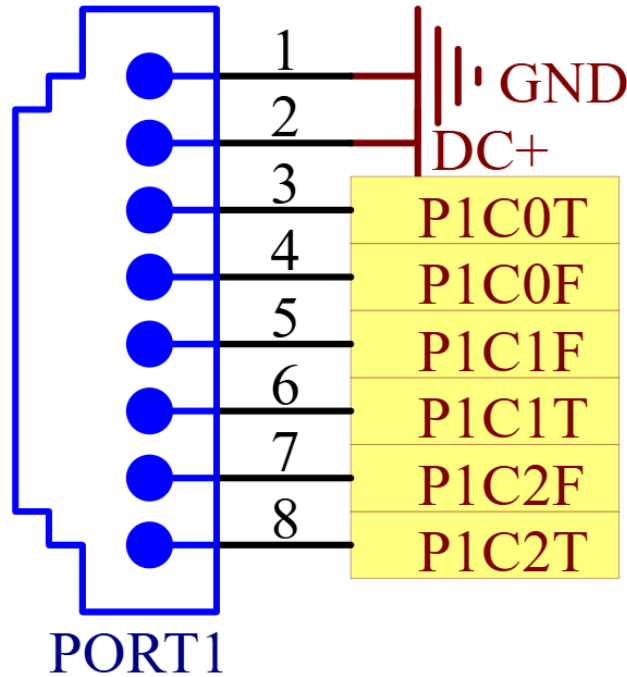

When testing the hub cabling all smart flow hubs and sensors will need to be disconnected as this will interfere with industry standard test tools.

A test report showing each cable has been tested should be provided to Enware at the completion of the hub cabling.

Start	Port 1	Port 2	Port 3	Port 4	Port 5	Tested By	Test Date	Comment (only if required)
<b>Hub 001</b>	Pass	Pass	Pass	N/C	N/C			
<b>Hub 002</b>	Pass	Pass	Pass	Pass	N/C			
<b>Hub 003</b>	Pass	Pass	Pass	Pass	Pass			
<b>Hub 004</b>	Pass	Pass	Pass	Pass	N/C			
<b>Hub 005</b>	Pass	Pass	Pass	Pass	Pass			
<b>Hub 006</b>	Pass	Pass	Pass	Pass	N/C			
<b>Hub &lt;last&gt;</b>	Pass	Pass	Pass	N/C	N/C			

## Hub Cabling Labeling

Each hub cable should be labeled at both ends in the format of yyy-z where yyy is the hub number (001 to 999) and z is the hub port (1 to 5). The cables should be labeled so that the labels are visible when plugged into the hub.

