

Smart Flow Water Monitoring System

Smart Flow Hard Wired Overview

Document Date: 2026-04-10



Table of Contents

Table of Contents	2
Smart Flow Monitoring Component Summary	3
System Overview	4
Scope overview	5
Enware Scope.....	5
Cabling Contractor Scope	5
Plumber Scope	5
Builder Scope.....	5
Contractor Responsibility Assignments.....	6
System Architecture.....	7
Hub Numbering	8
TMV Monitoring Plans.....	9
TMV & Fixture Monitoring Plans	10
Hospital IT Network	11
Cabling System Design Guide	12
RS485 Backbone Cabling	13
Hub Cabling (Hub to TMV / Fixture).....	14
Smart Flow Azure	15
Azure Architecture.....	15
Benefits	16
Aggregation of Existing Smart Flow Sites.....	16
Live Temperature Monitoring.....	17
Advanced Reporting	18
Compatible Thermostatic Mixing Valves (TMV)	20
Background Information.....	21
Company Introduction	21
Smart Flow SFM Installations	22
Warranty	23
Quality Assurance & Standards	23

Smart Flow Monitoring Component Summary

The system consists of the following monitoring system components, quantities vary by site:

Code	Description
SF-SAAS	Smart Flow AZURE SaaS Platform ongoing monthly SaaS licence fee paid for by the Facility (monthly fee per TMV)
SF-MANAGEDSERV	Smart Flow AZURE managed services ongoing monthly licence fee paid for by the Facility (monthly fee per TMV)
SFM9000-TMV	Smart Flow 2.0 Kit Per TMV includes required Hardware and System Commissioning
SFM4000-C	Stainless steel hub cabinet with a backbone connector
ATMSHL-350	Stainless steel hub cabinet lid
SFM5200	SMARTFLOW LAN INTERFACE 24V RACK MOUNT
SFM6100	SFM SERVER
SFM6510	SMARTFLOW BMS INTERFACE - BACNET
SFM9000C	SMARTFLOW CABLE TERMINATIONS PER TMV (OPTIONAL)

Items not included in above:

- Enware AquaBlend TMVs with Smart Flow mixing chamber
- CAT6 Backbone daisy chain cabling between the LAN interface and each of the hubs
 - We can offer a service to terminate the cables (see SFM9000C above)
- CAT6 Hub cabling between hubs and TMVs / fixtures
 - We can offer a service to terminate the cables (see SFM9000C above)

System Overview

Smart Flow® addresses Health Industry challenges of complying with the policy obligations as defined by federal and state regulators, improving the overall patient experience, protecting brand reputation as well as revenue flows and addresses some of the sustainability challenges of operating a Health Facility. This is accomplished, whilst reducing operating costs by up to 65% against manual industry best practice.

Enware's system achieves this by providing auditable data and reporting in alignment with State and Federal Legislation and Guidelines. Key risk areas addressed include:

- **Stagnation Prevention:** Reporting identifies what and when to flush throughout the system to reduce the risks of stagnation. Smart Flow® achieves this while alleviating unnecessary wastage of Energy, Water and Labour
- **Specified Temperature Delivery:** Provides confirmation that the water supply and the Thermostatic Mixing Valve (TMV) are performing within the desired parameters while also identifying Temperature Alert and Alarm Events which present a scalding risk to Patients and Staff
- **Maintenance:** Provides confirmation and documentation required maintenance has been carried out within the set criteria as stipulated by the TMV manufacturer.

Smart Flow System Features

- 24/7 temperature monitoring of TMVs (End-Of-Line Fixture Monitoring - Optional)
- Alert status for over temperature events
- Stagnation Reporting
- TMV Monthly Temperature readings.
- Complete Historical Data for every TMV
- Complete Historical Data for every Alert event
- Performance reports on every TMV
- Historical Data Logs are third party NATA certified in the event of patient / visitor liability claims
- Full reporting options to meets engineering staff requirements
- BMS BACnet IP Interface

The system does not alter or change the performance of the TMV in any way but provides constant temperature readings for analysis. Smart Flow may be designed to meet the specific requirements of the client. Please contact Enware to discuss your specific requirements as needed.

The hard-wired Smart Flow Monitoring System is ideal for new installations and may also be retrofitted to existing hospitals or aged care facilities using our Wireless retrofittable option.

Scope overview

The scope for the Smart Flow Water Monitoring System is as follows:

Enware Scope

- **SFM Backbone Dual Connectors:** Supply of backbone connectors
- **HUB Cabinets:** Supply of hub cabinets
- **Initial System Plans:** Supply of plans for all cable runs and locations
- **As-Built Plans:** Final markup of as-built plans
- **SFM LAN Interfaces:** Supply, configuration, installation and testing
- **SFM TFP HUBs:** Supply, addressing, installation and testing
- **TMV & Fixture Sensors:** Supply, installation and testing
- **Smart Flow Backbone Testing:** Confirming that all devices are connected on the RS485 network
- **Client Training:** Client training of usage of the Smart Flow Monitoring system

Cabling Contractor Scope

- **RS485 Backbone cables:** Supply of CAT6 cable, installation, termination & testing
- **Hub to TMV & Fixture Cables:** Supply of CAT6 cable and RJ45 plugs, installation, termination, testing and labelling.
- **Conduit:** Supply and installation of conduit, we recommend 20mm from the TMV / Fixture to the ceiling and 40mm from the hub cabinet to the ceiling.
- **Testing:** Supply of test results for all cabling
- **Markup Plans:** Markup of any changes to initial system plans

Plumber Scope

- **Hub Cabinets:** Installation of hub cabinets in the walls including lids at a preferred height of 1.5m
- **TMV/Fixture Schedule:** A spreadsheet linking the hub ports to the TMV/fixtures and providing asset location information and information on the rooms serviced as per Enware's hub numbering design guidelines
- **Communication of changes:** regarding added or deleted TMVs or fixtures during the build
- **Plans:** Initial and final as-built plans clearly showing TMV locations

Builder Scope

- **Co-ordination:** Co-ordination of services
- **BMS Integration:** Co-ordination of BMS integration requirements
- **IP addresses:** Provision of IP address allocations and rack allocations
- **Room Naming:** Provision of Hospital wayfinding room naming information
- **Training:** Co-ordination of client training

Contractor Responsibility Assignments

Component	Installed location	Supplied by	Installed by	Timing	Notes
System Engineering Design	n/a	Enware	n/a	Commencement of Project	Design to be supplied at commencement and modified and updated as required
SFM hub Cabinets	In corridor walls as shown on plans	Enware	Plumber	At plumbing rough in stage	Hub cabinets installed at the same time as TMVs
HUB to TMV & Fixture Cable Rough In (CAT6)	Walls and ceilings between hubs and TMVs / fixtures	Cabling Contractor	Cabling Contractor	At plumbing rough in stage	Cabling contractor to supply CAT6 cable and rough in.
HUB to TMV / fixture cable terminations & test (RJ45)	Walls	Cabling Contractor	Cabling Contractor	After Cable Rough in	Cabling contractor to supply RJ45 plug, terminate, test, label and markup plans.
Backbone Cable Rough In (CAT6)	Walls and ceilings between hubs	Cabling Contractor	Cabling Contractor	Prior to plastering	Cabling contractor to supply CAT6 cable and rough in.
Backbone Cable terminations & test (RJ45)	Walls	Enware	Cabling Contractor	Prior to plastering	Enware to supply backbone connectors Cabling contractor to terminate, test, label and markup plans.
Conduit	Walls	Cabling Contractor	Cabling Contractor	At plumbing rough in stage	We recommend: TMV / fixture and ceiling: 20mm Hub cabinet to ceiling: 40mm
SFM TFP HUBS	In hub cabinets	Enware	Enware	System commissioning	Not installed until all plastering and painting is completed
Cable Audit	N/A	Enware	N/A	System commissioning	Enware will audit the backbone and hub to TMV / fixture cabling to ensure it is correct & matches the plans.
LAN Interfaces	Comms Rooms on each level	Enware	Enware	System commissioning	Installed when Comms rooms are completed and active equipment has been installed.
On-Prem Server	Central Comms Room	Virtual Machine: LHD IT	LHD IT	System commissioning	
		Physical: Enware	Enware		
SFM Azure Platform	Cloud	Enware	Enware	System commissioning	Commissioned once: - TMV / fixture schedule is finalized. - IP network details are finalized - On-prem server is commissioned - On-prem server to Azure connection is working
Client Training	On site / Cloud	Enware	Enware	System Handover	Training on how to use the system

System Architecture

The Smart Flow System utilizes three cabling network components in the complete system architecture.

These are:

1. **Hospital IT Network** – supplied by others
2. **RS485 Backbone Network** – connects Smart Flow field devices (HUBs) together back to the Comms Room
3. **HUB Cabling** – connects sensors at TMVs and Fixtures back to HUBs

The system design can be replicated without limit over multiple levels and buildings. Each level will contain its own RS485 Network cabled back to a LAN Interface on each Level. Enware will supply Plans showing all HUB locations, the backbone system design, and all connected endpoints for sensors, either TMVs or fixtures.

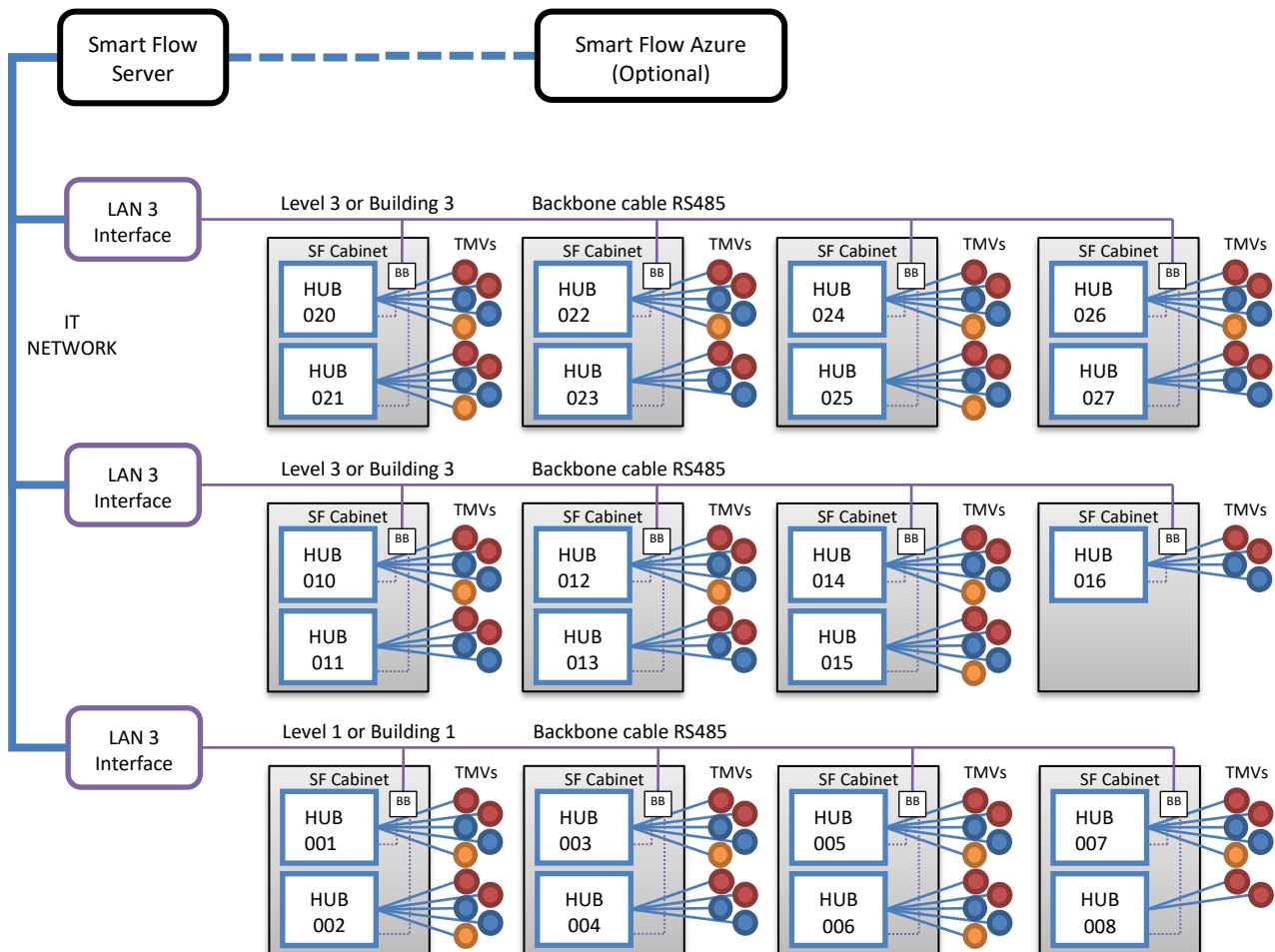

Note: The RS485 Backbone Cable and hub to TMV / fixture cabling **are not** part of the structured cabling network. All cable should be installed by a qualified person.

Hub Numbering

Hubs are to be numbered sequentially along the backbone from the LAN interface (comms room) end of the backbone to the last hub, hubs are numbered sequentially along the backbone to assist with diagnosing faults in the backbone.

We start the hub numbers at 001 for the first hub in the hospital, usually starting at the lowest floor and working our way up as this is typically how projects are delivered.

Between backbones we leave a gap and round up to the nearest 10 to allow for minor design changes without having to re-number all hubs. For example, the hubs might be:

- GND: HUB001, HUB002, HUB003, HUB004, HUB005
- L1: HUB010, HUB011, HUB012, HUB013, HUB014, HUB015, HUB016, HUB017, HUB018
- L2: HUB020, HUB021, HUB022, HUB023, HUB024, HUB025, HUB026, HUB027
- ...

Since each Smart Flow Hub Cabinet (SFM4000C) can fit two Smart Flow TFP Hubs (SFM-TFPHUB), we will typically allocate two hubs in each cabinet to minimise the number of hub cabinets (up to 10 TMV/fixtures), this may not always be practical in the base that there are 5 or fewer TMVs within 50m of the hub cabinet, in this case another hub cabinet will be required.

TMV Monitoring Plans

The example below shows a typical plan that will be supplied to the contractor by Enware. This plan will show the suggested locations of HUB cabinets. As HUB cabinets installed in walls are considered an architectural item and should be included in the Architectural Plans, final locations will need to be confirmed by others. Hubs should be installed in the walls in the corridors. The backbone cable should be run in the route shown, **any changes to backbone routing due to onsite practicalities shall be documented on the site plans and reported back to Enware.** The hub cabling cable should be run to the hub and hub port shown on the plans, **any changes to hub cabling due to onsite practicalities shall be documented on the site plans and reported back to Enware.**

As can be seen on the plans, TMVs are labelled based on the hub number and port number in the format:

- “TMV YYY-Z” eg “TMV 004-1”
 - YYY is the hub number (address) starting at 001
 - Z is the hub port (sensor port position) starting at 1

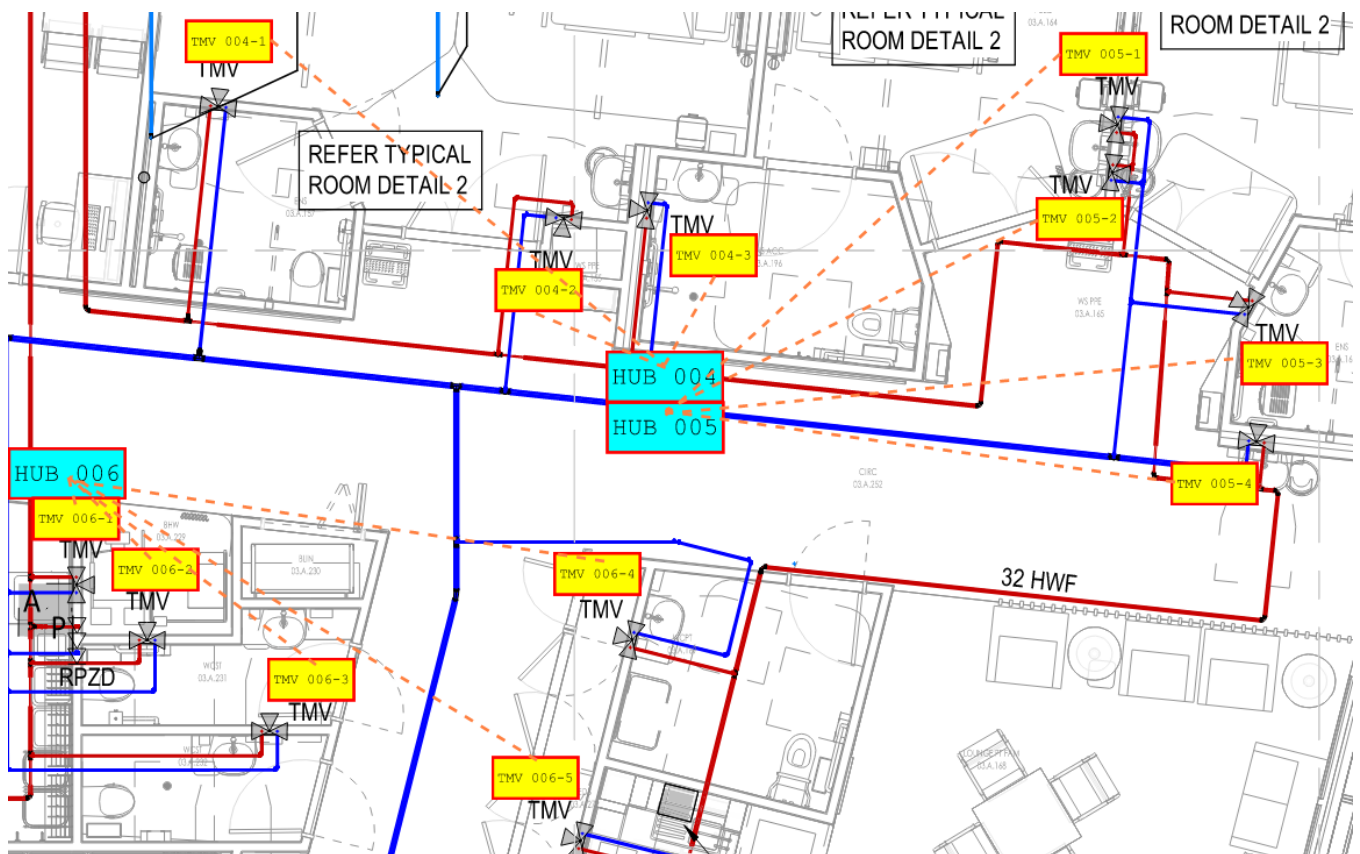

TMV & Fixture Monitoring Plans

The example below shows a typical plan that will be supplied to the contractor by Enware. This plan will show the suggested locations of HUB cabinets. As HUB cabinets installed in walls are considered an architectural item and should be included in the Architectural Plans, final locations will need to be confirmed by others. Hubs should be installed in the walls in the corridors. The backbone cable should be run in the route shown, **any changes to backbone routing due to onsite practicalities shall be documented on the site plans and reported back to Enware.** The hub cabling cable should be run to the hub and hub port shown on the plans, **any changes to hub cabling due to onsite practicalities shall be documented on the site plans and reported back to Enware.**

As can be seen on the plans, TMVs and fixtures are labelled based on the hub number at port number in the format:

- “XXX YYY-Z” eg “TMV 001-1”
 - XXX: the asset type eg:
 - TMV: Thermostatic Mixing Valve
 - BSN: Basin
 - SWR: Shower
 - YYY is the hub number (address) starting at 001
 - Z is the hub port (sensor port position) starting at 1

For assets that are virtually monitored the following convention is used:

- “XXX YYY-ZV” eg “BSN 001-1V”
 - XXX: the asset type eg:
 - BSN: Basin
 - SWR: Shower
 - YYY is the hub number (address) starting at 001
 - Z is the hub port (sensor port position) of the upstream TMV

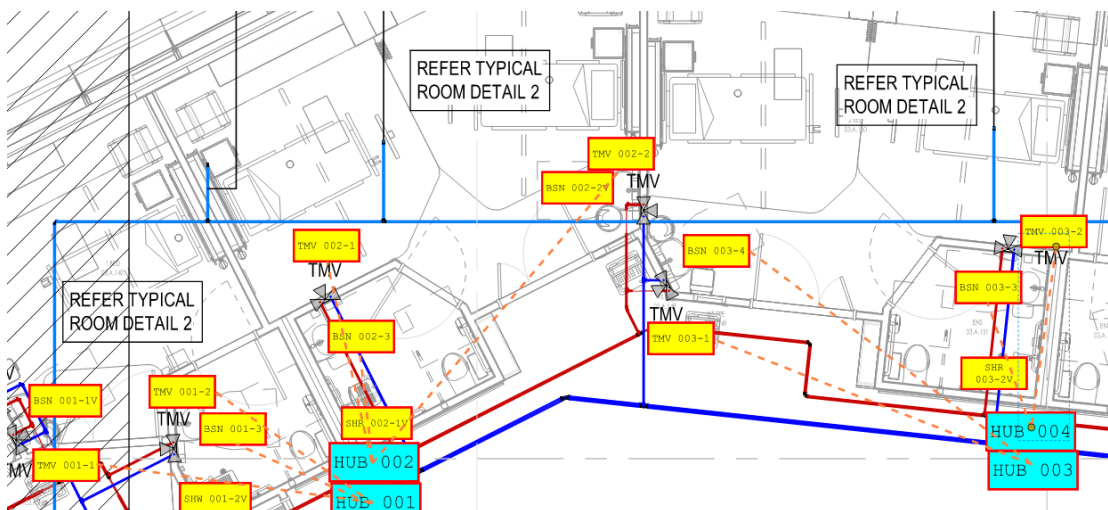

Hospital IT Network

The hospital IT network is not part of this scope, it is up to others to provide essential networking equipment such as space in the racks, switch ports, IP addresses etc.

The hospital IT network is the Structured Cabling Network and stands separate from Smart Flow System Cabling. The Smart Flow system utilizes the Hospital IT Network to efficiently communicate across the whole Hospital site.

An on-premises server is typically required for each Smart Flow installation, this server may be a physical server provided by Enware (order code SFM6100) or a virtual machine provided by hospital IT. If it is a physical server, it will be installed in the rack by Enware.



Each floor of each building will typically have a single RS485 backbone between each of the hubs which run back to comms room where the 24V LAN Interface (SFM5200) is in the rack. The Smart Flow LAN Interface connects to the hospital IT network via ethernet. The LAN Interfaces are installed in the rack by Enware.



The LAN Interfaces communicate with the server via the hospital network, the server will communicate to both the BMS via BACnet IP and the Smart Flow Azure Cloud Service that aggregates multiple Smart Flow installations throughout a local health district or private operator into a single management portal ssf.smartflow.com.au.

Below is an example of the details that we will require from the organisation that is managing the IT network:

Smart Flow - IP Address Allocations																	
Device	Description	MAC Address	Building	Device Location	Device Rack ID	Device Rack Position server: 2RU LAN Interface: 3RU	IP Address allocation	Subnet mask	IP Gateway Address	IP Switch Rack & Switch Name	IP Switch Port	RS485 Patch Rack & Panel Name	Backbone ID	RS485 Patch Port	Start and Finish Hubs	BACnet Network Number	BACnet Device Instance Number
1 x Dell Power Edge Server	WMS Server WMS Bacnet			Comms Room												1	125
SF LAN Interface 01	RS485 to IP Interface			Comms Room GND													
SF LAN Interface 02	RS485 to IP Interface			Comms Room L1													
SF LAN Interface 03	RS485 to IP Interface			Comms Room L2													

Cabling System Design Guide

These guidelines are necessary to ensure the system meets its performance requirements including functionality, reliability and maintainability.

RS485 Backbone:

- **Architecture:** RS485 daisy chained from hub cabinet to hub cabinet
 - Star or Tee connections are not allowed for RS485.
- **Cable:** CAT6 unshielded.
- **LAN Interface:** Each RS485 backbone starts at a LAN interface. Located in the comms room rack. A single backbone shall not traverse from one floor to another or from one building to another.
- **Terminations:** SFM backbone connector at each hub cabinet, except in comms room where it is terminated in the patch panel.
- **Service Loop:** 0.5m service loop in the ceiling space above each hub cabinet.
- **Conduit:** 40mm conduit between the hub cabinet and the ceiling space.
- **Hub Cabinet Installation:** Hubs to be installed in cabinets on the walls at height of under 1.5m
- **Hubs Per Cabinet:** 1 to 2 hubs per cabinet (5 to 10 TMVs/Fixtures), leave at least 1 TMV/Fixture port unused in each cabinet to allow for design changes.
- **Hubs Per Backbone:** 26 hubs max.
- **Cable Length:** 500m max (total length).
- **Hub Numbering:** Hubs to be numbered in sequential order (see "Hub Numbering" section).
- **Labelling:** Label the incoming and outgoing cables (see "Backbone Labelling" section).
- **Testing:** Wire continuity testing from the first termination in comms room patch panel to each SFM backbone connector in the hub cabinets.
 - A test report showing this has been tested is required (see "Backbone Testing" section in the "SFM Cabling Installation Scope").

Hub Cabling (Hub to TMV/Fixture):

- **Cable:** CAT6 unshielded.
- **Terminations:** RJ45 plugs both ends (T-568A).
- **Service Loop:** 0.5m service loop in the ceiling space above each hub and TMV/fixture.
- **Conduit:** 20mm conduit between the TMV and the ceiling space.
- **Cable Length:** 50m max.
- **Labelling:** At both ends, label the cable (see "Hub Cable Labelling" section in the "SFM Cabling Installation Scope")
- **Testing:** Wire continuity testing of each cable to confirm both the pin mapping and labelling is correct.
 - A test report showing each cable has been tested is required (see "Hub Cable Testing" section in the "SFM Cabling Installation Scope").

RS485 Backbone Cabling

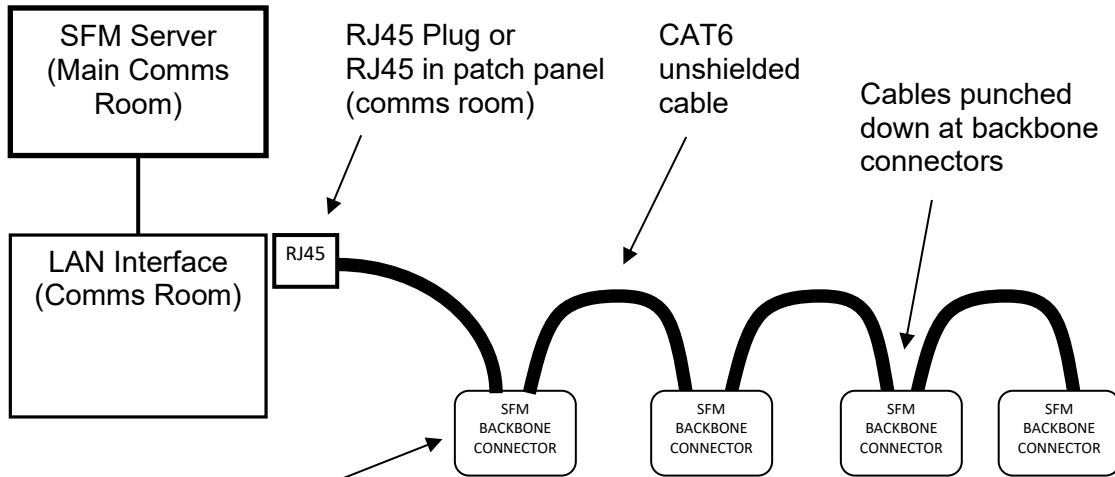

DESC: SFM BACKBONE DUAL CONNECTOR SURFACE MOUNT
MFR: Enware
CODE: SFM-BB-SURFACE

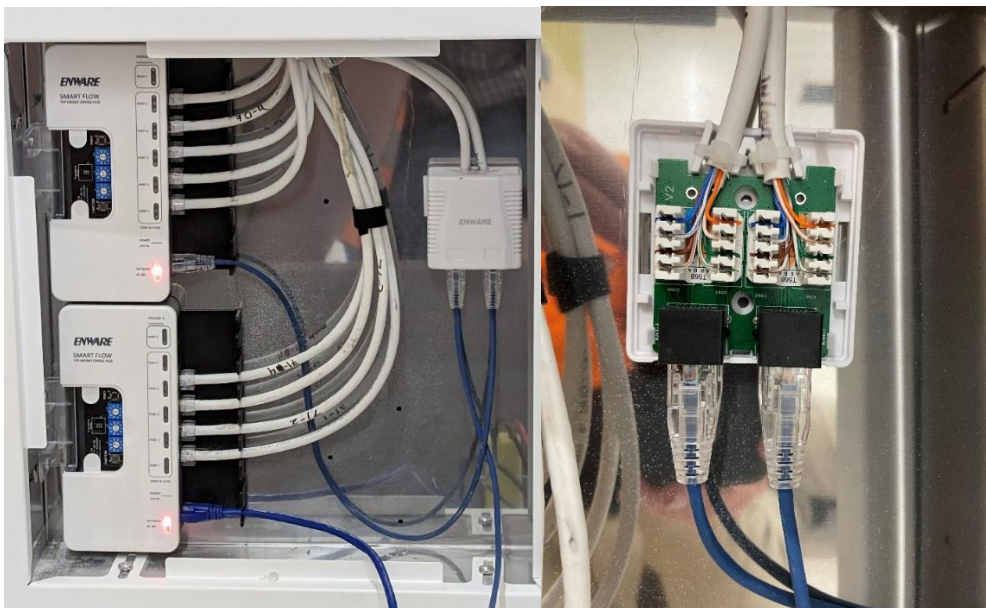
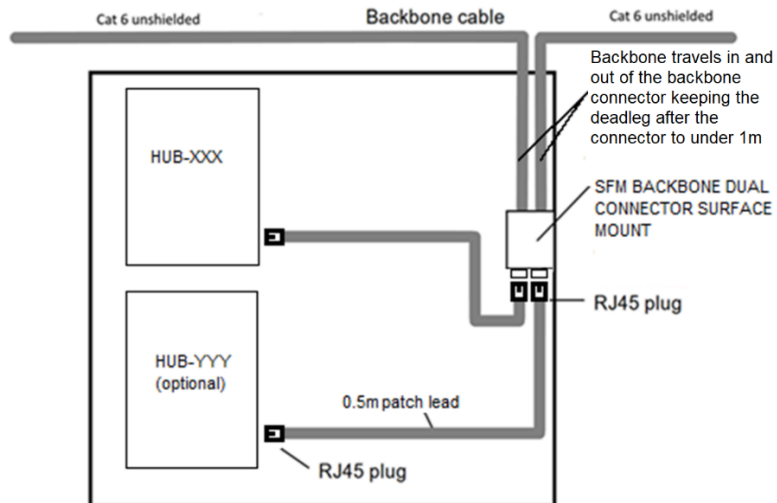

Please see the "SFM Cabling Installation Scope" document for further details.

Hub Cabling (Hub to TMV / Fixture)

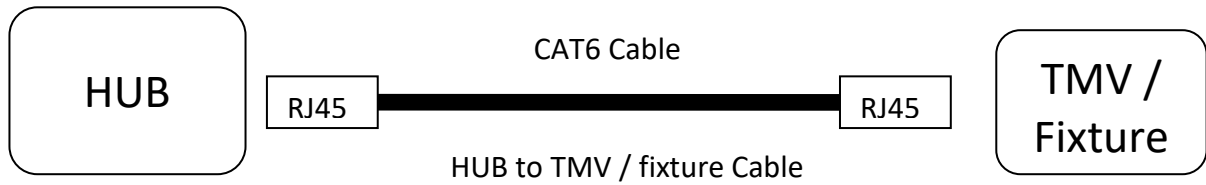

Each hub can support up to 5 TMVs / fixtures on ports 1-5 and 2 pressure sensors on port 6.

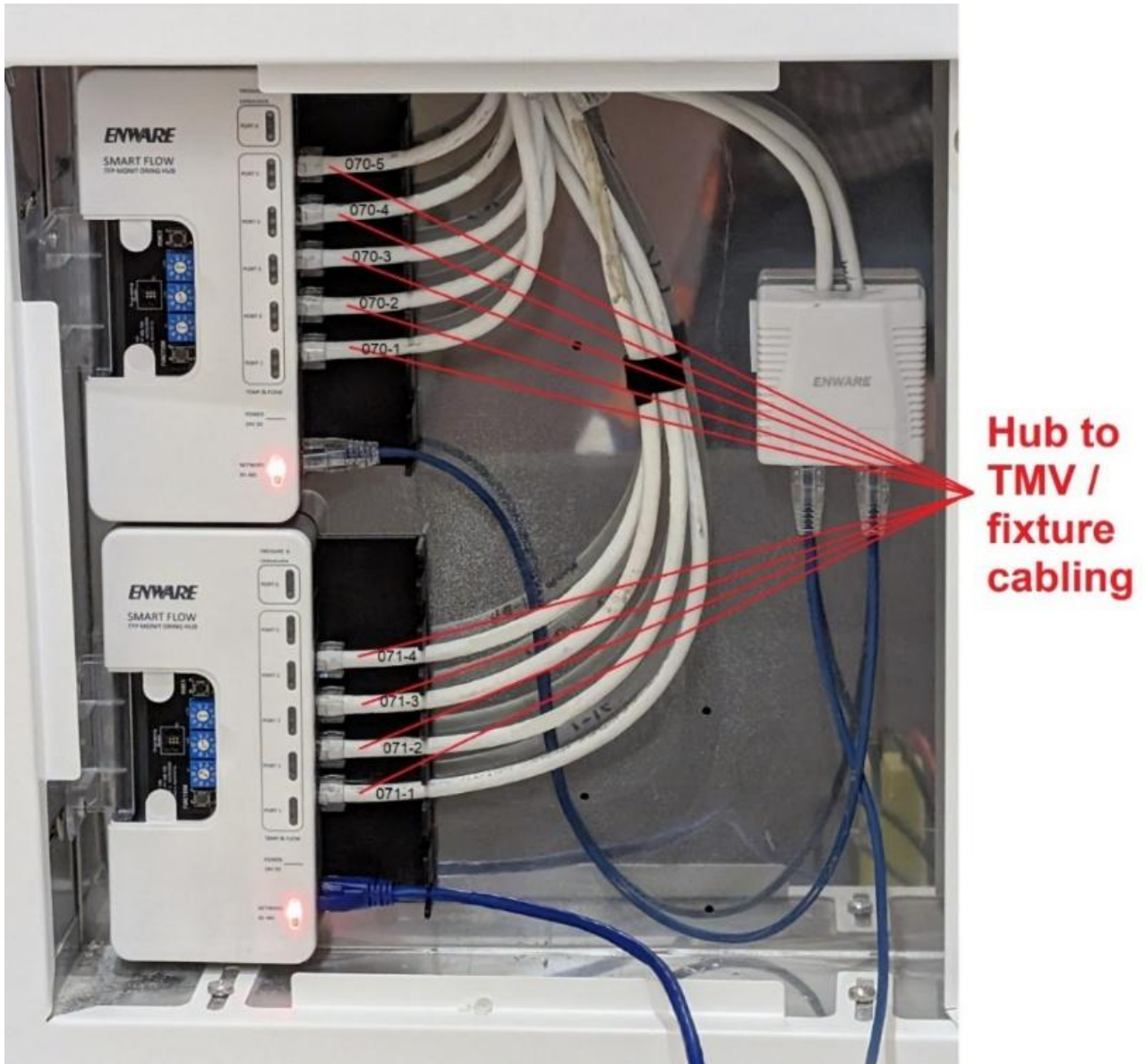

Please see the "SFM Cabling Installation Scope" document for further details.

Smart Flow Azure

Enware’s Smart Flow in Azure cloud platform is the universal SAAS solution for TMV Monitoring, providing a seamless managed platform where Risk is minimised and compliance is enhanced. The release of the Smart Flow Azure enables a single solution for multiple sites, allowing both existing and new installations to be reported through a common user interface providing a fully integrated fleet management solution.

The multi-tenant Smart Flow platform provides an organisation with total fleet management in a single instance of the software. With Role Based Access Control, organisations can allow appropriate access to all sites or a single location for ease of management, compliance, and governance.

Azure Architecture

Facility IT Requirement: For deployment of the Smart Flow® system to the Cloud Application, the facility will need to provide a Secure VPN Connection.

Secure Cloud Based Application: Developed in Azure, the Smart Flow Application has been built under the controls of ISO:27001 to provide piece of mind. As the system transmits through a Lora Wan Radio Frequency network independent of the Facilities assets. The installation of Smart Flow® requires the facility to provide a secure VPN for the transmission of single directional data to the Azure based application.

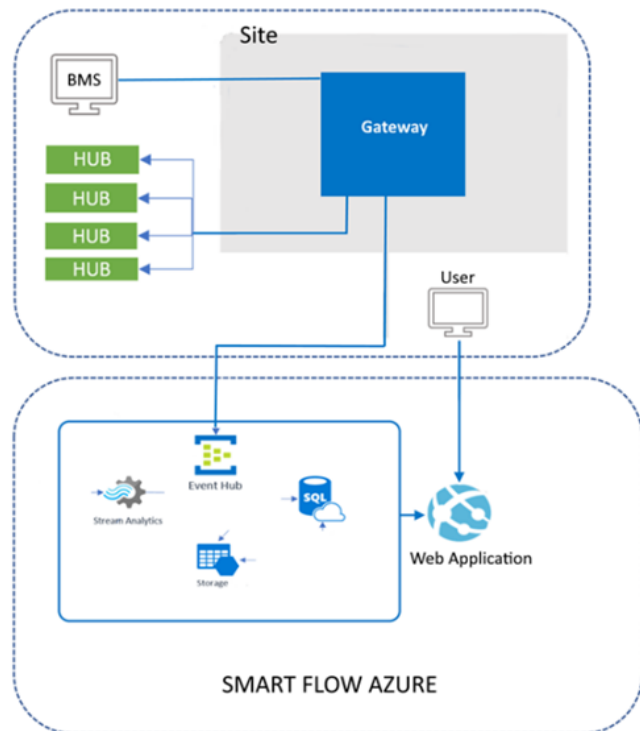

Due to the critical nature of this piece of infrastructure Enware strongly recommend adoption of the annual Service and Maintenance Contract to maintain the Smart Flow system. This includes technical Software support (via remote access recommended); telephone support, data interrogation, annual site visit, additional training, software upgrades and additional reporting documentation and annual, Smart Flow Software License fee. The fee for this contract is dependent on the size and location of the project and comes with a detailed document highlighting the contracts terms and conditions.

Benefits

- Multi-tenant Smart Flow instance
- Role based access control (RBAC)
- Support offered across all sites with equal response times
- Unified solution for all sites
- Feature upgrades rolled out simultaneously
- Guaranteed uptimes due to centralised monitoring
- Standardised training path for users
- Compliance standardisation

Aggregation of Existing Smart Flow Sites

With Smart Flow Azure multiple sites can be aggregated into a single management portal enabling simplified management from anywhere.

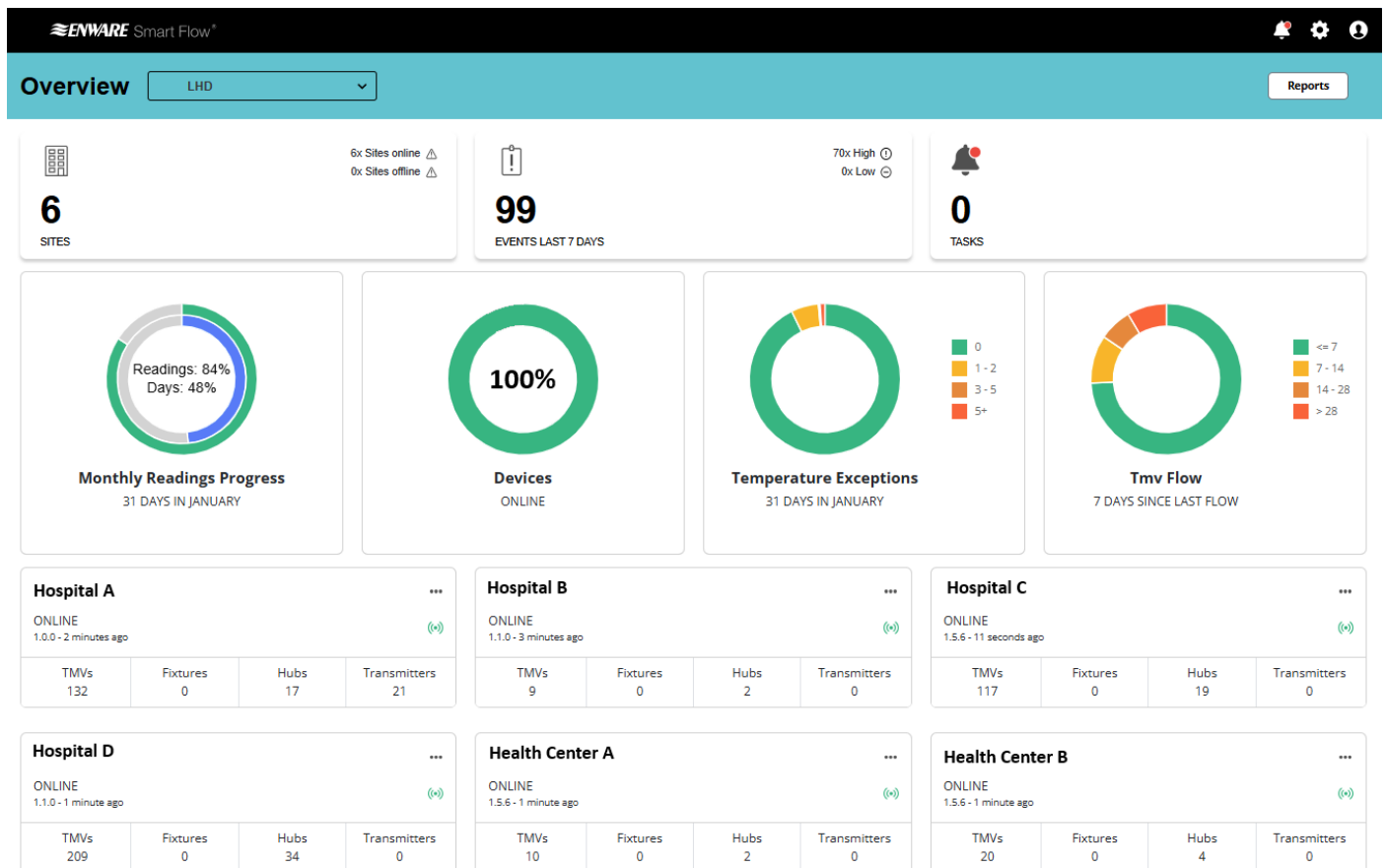

Copyright © 2026 [Enware Australia Pty Limited](#). All rights reserved.
Build Version: 1.7.0

Live Temperature Monitoring

ENWARE Smart Flow®
🔔 ⚙️ 👤

🔧 **Live Temperatures** Hospital A

All Locations ▾

▶ B03, L00, Renal **TMVs** 33 25 20 31 22 20.5 19 21.5

▶ B21, L00, EMERGENCY **TMVs** 25 20 33.5 34 34.5 22 40 33.5 39 39 25.5 27.5 36.5 25.5

25 26.5 22 34 40 22 25 22.5 35.5 31.5 25.5 41 36 21.5

13.5

▶ B21, L01, RENAL **TMVs** 25.5 21 30.5 25 39.5 22 35.5 25 27 25.5 25 35 36.5 37

39.5 38.5 33.5 40 29 36.5 32.5 34 20.5 36.5 39 25.5

▶ B21, L02, MATERNITY **TMVs** 33.5 36.5 32 22 22 35.5 35 26 22 31 25.5 25 25 23

20 20.5 28 30 35.5 32.5 26.5 20 22 27

▶ B21, L03, ONCOLOGY **TMVs** 19.5

Advanced Reporting



Temperature Exception Events - Detailed View

Fleet Health Report for October 2024

TMV ID
TMV 293

TMV Location
L2, Theatres, Female staff WC

Exception Details
Started at 25-Oct-2024 12:07:46 PM
and ended at 25-Oct-2024 12:10:28 PM

Duration
00:02:42

Comments
Excessive Over Temperature Events - recommend checking set temperature of TMV

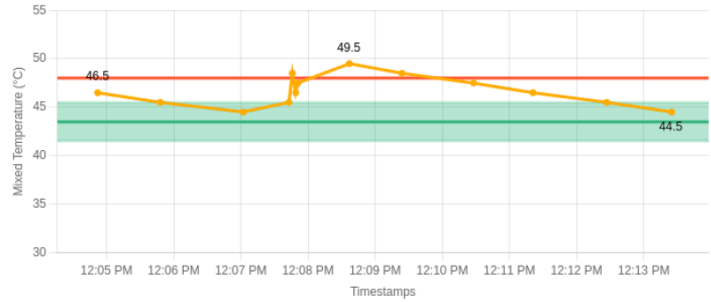

TMV ID
TMV 245

TMV Location
L3, Surgery, Male WC west side

Exception Details
Started at 04-Oct-2024 11:50:30 PM
and ended at 04-Oct-2024 11:51:33 PM

Duration
00:01:03

Comments
Excessive Over Temperature Events - recommend checking set temperature of TMV

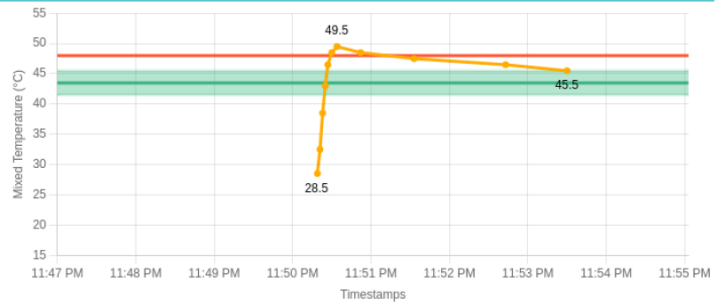

Temperature Exception Details

Fleet Health Report for October 2024

GRADE	TMV ID	LOCATION	EXCEPTION COUNT	START TIME	END TIME				
HIGH	TMV 293	L2, Theatres, Female staff WC	390	01-Oct-2024 07:29 AM	01-Oct-2024 07:34 AM				
				01-Oct-2024 10:55 AM	01-Oct-2024 10:58 AM				
				01-Oct-2024 11:47 AM	01-Oct-2024 11:48 AM				
				01-Oct-2024 12:02 PM	01-Oct-2024 12:03 PM				
				01-Oct-2024 12:21 PM	01-Oct-2024 12:25 PM				
				01-Oct-2024 12:29 PM	01-Oct-2024 12:30 PM				
				01-Oct-2024 12:49 PM	01-Oct-2024 12:53 PM				
				01-Oct-2024 01:41 PM	01-Oct-2024 01:45 PM				
				01-Oct-2024 01:46 PM	01-Oct-2024 01:49 PM				
				01-Oct-2024 02:03 PM	01-Oct-2024 02:06 PM				
				370 exceptions omitted					
				30-Oct-2024 02:00 PM	30-Oct-2024 02:02 PM				
				30-Oct-2024 02:33 PM	30-Oct-2024 02:36 PM				
				30-Oct-2024 03:35 PM	30-Oct-2024 03:40 PM				
				30-Oct-2024 03:53 PM	30-Oct-2024 03:55 PM				
				30-Oct-2024 03:57 PM	30-Oct-2024 03:59 PM				
				30-Oct-2024 04:01 PM	30-Oct-2024 04:04 PM				
				30-Oct-2024 04:04 PM	30-Oct-2024 04:07 PM				
				30-Oct-2024 04:43 PM	30-Oct-2024 04:46 PM				
				30-Oct-2024 09:52 PM	30-Oct-2024 09:55 PM				
				31-Oct-2024 12:29 AM	31-Oct-2024 05:36 AM				
				HIGH	TMV 245	L3, Surgery, Male WC west side	119	01-Oct-2024 09:45 AM	01-Oct-2024 09:47 AM
								01-Oct-2024 12:52 PM	01-Oct-2024 12:57 PM
								01-Oct-2024 01:24 PM	01-Oct-2024 01:27 PM
								01-Oct-2024 02:50 PM	01-Oct-2024 02:52 PM
								01-Oct-2024 03:30 PM	01-Oct-2024 03:33 PM
								01-Oct-2024 09:28 PM	01-Oct-2024 09:30 PM
								01-Oct-2024 09:43 PM	01-Oct-2024 09:50 PM
								01-Oct-2024 10:43 PM	01-Oct-2024 10:48 PM
								02-Oct-2024 09:13 AM	02-Oct-2024 09:18 AM
								02-Oct-2024 12:56 PM	02-Oct-2024 12:59 PM

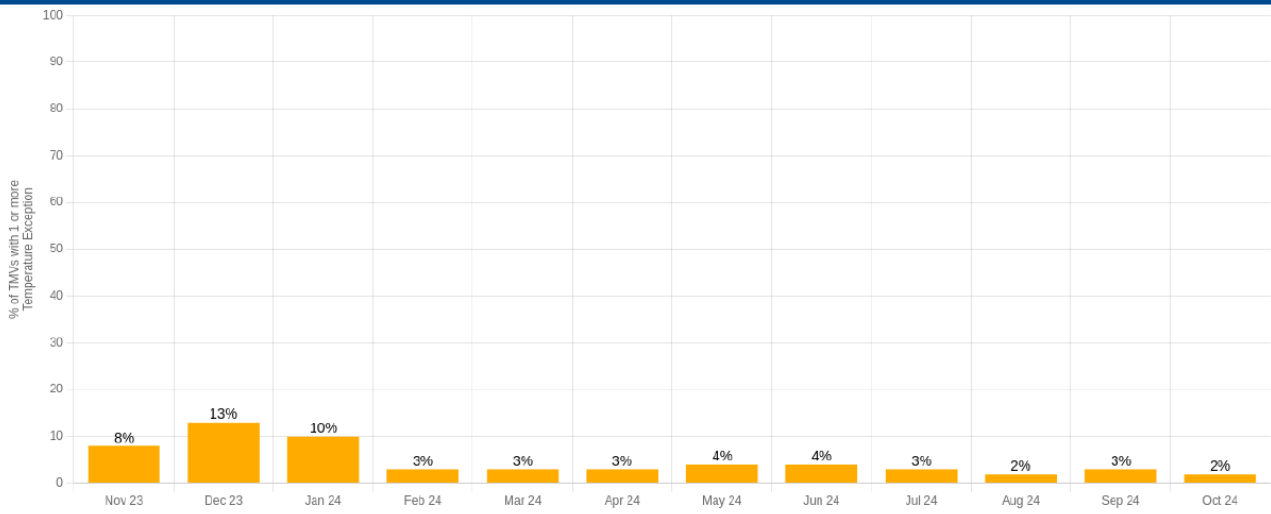

Compatible Thermostatic Mixing Valves (TMV)

The Smart Flow system should be installed with Enware Aquablend TMVs that include a Smart Flow mixing chamber with an integral temperature probe.

Below is an example (ATMS719SF-350) of a typical Aquablend 1500 TMV with a Smart Flow Mixing Chamber.

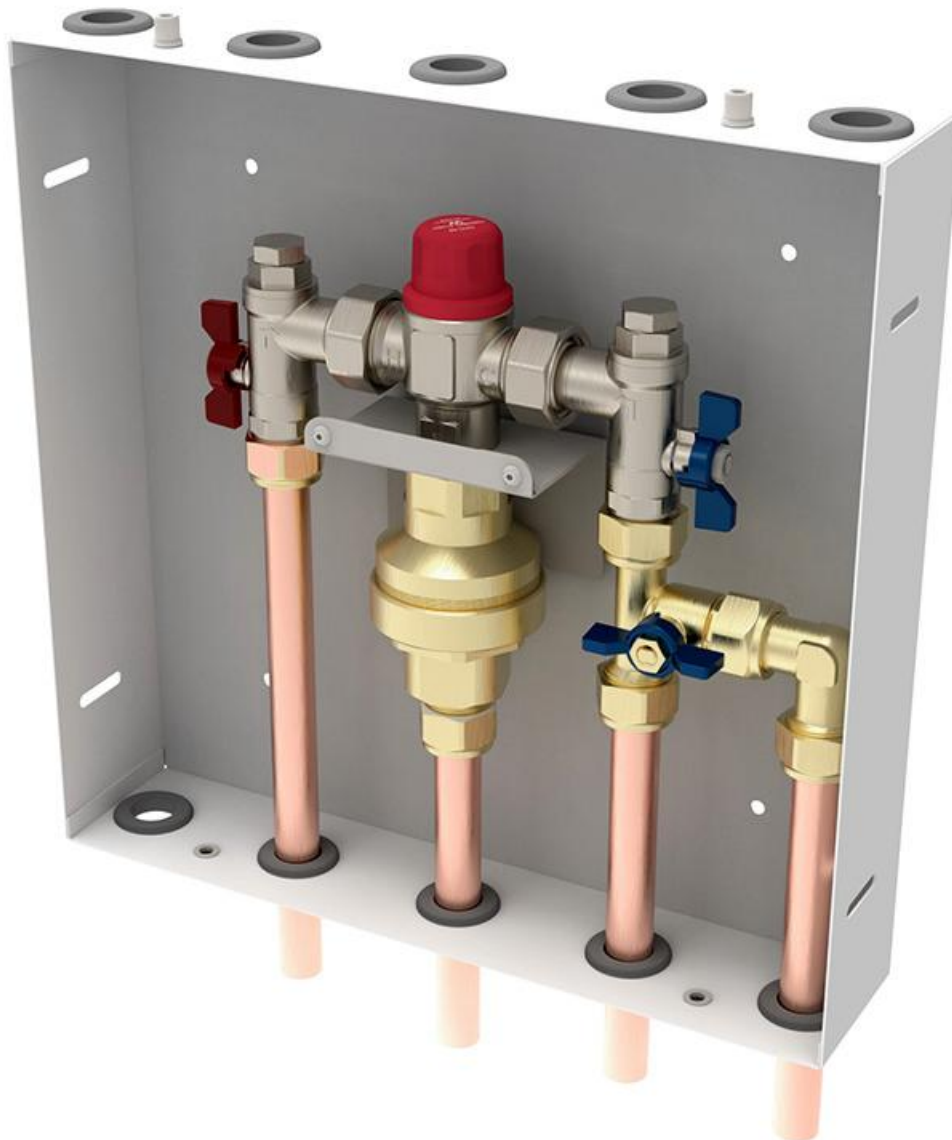

Background Information

Company Introduction



Enware is a leading local manufacturer of tapware & valves for the commercial, industrial & institutional marketplace since 1937. With our manufacturing facility located at Caringbah in Southern Sydney, Enware has offices in various states of Australia, as well as offices in Singapore, Dubai, Europe & New Zealand, where we supply our government & infrastructure based clientele such as hospitals, prisons, police stations, universities, councils & schools with our durable locally made and designed tapware, valves and associated monitoring systems.

Smart Flow SFM Installations

With our extensive experience supplying Healthcare facilities throughout Australia and overseas for over 70 years, Enware Australia understands the unique hydraulic requirements within such facilities. The Smart Flow TMV monitoring system was developed to meet the mandatory NSW Department of Health requirements of monthly temperature testing imposed in the early 2000s (refer DOH circular C2004/10) and has been successfully installed into numerous health projects in NSW and interstate over the last 10 years.

Projects include:

- Gold Coast University Hospital
- Mater Hospital Newcastle
- Lismore Hospital Mental Health Unit
- Dubbo Hospital
- Nepean Hospital Stages 1,2,3,4,
- Mackay Hospital
- Wagga Hospital Mental Health Unit
- Auburn Hospital
- Belmont Hospital
- Lismore Hospital Integrated Cancer Care Unit
- Nyngan Hospital
- John Hunter Hospital
- RPA Lifehouse
- Port Macquarie Base Hospital
- Wollongong Hospital
- Parkes Hospital
- Forbes Hospital
- Liverpool Hospital
- Westmead Hospital CASB
- Griffith Base Hospital
- Campbelltown Hospital
- Hornsby Hospital
- Baptist Care Elderslie
- Baptist Care Caloola
- Canberra Hospital – SPIRE
- North Canberra Hospital
- Macquarie University Hospital
- Prince Of Wales CASB
- Sydney Children’s Hospital

Warranty

Please refer to the warranty document on our website <https://www.enware.com.au/pages/service-warranty>

Quality Assurance & Standards



Enware Australia is a fully accredited quality endorsed company to ISO 9001. The Standard has formed the basis of our work principles to ensure the highest quality products and workmanship and safe working environment. The Enware Smart Flow system meets all requirements of AS3718. All outlets carry minimum 4 star WELS rating with showers being 3 star rated (maximum rating for showers).